



North American  
Safety Valve  
Industries, Inc.



**35,000** Safety & Relief Valves  
Ready to Ship

When the pressure is on, trust North American Safety Valve Industries

## We're Always on Standby

When you're under pressure, NASVI's ready to help.



### New & Remanufactured Safety Valves

Extensive stock of new valves from trusted, top manufacturers and dependable remanufactured valves back by a 2-year warranty.



### Same or Next-Day Shipping

Avoid or minimize downtime with NASVI's same or next-day shipping.



### State-of-the-Art Repair & Setting Centers

Nearly every safety valve's specifications are at our technicians' fingertips for exact work. Generally, irreparable valves can be replaced from our in-stock inventory.



### Turnaround Exchange Program

Receive the valves needed for installation prior to shutting down, then ship us the old valves for repair or exchange.

## Get an Instant Quote

[nasvi.com/quote](http://nasvi.com/quote)

1600 Warren St.  
North Kansas City, MO 64116

Phone: (800) 800-8882

Phone: (816) 421-7042

Fax: (816) 421-0297

[sales@nasvi.com](mailto:sales@nasvi.com)

spec sheet



# KINGSTON

Manufacturing reliable industrial valves for industry since 1908.

# 103H

## Safety Relief Valve

## Model 103H

Side Relief Outlet Valve, Soft Seat



### Features

- Precision Machined Brass Inlet
- Red Brass Body
- Viton Disc For Soft Seat Performance
- Stainless Steel Spring
- NPT Side Outlet for Direct Connection
- Liquid & Non-Code Air Applications
- Maximum Temperature 250 °F
- Available Sizes: 1/4" NPT
- Set Pressure Range 5-500 PSIG

Model	Inlet Size	Orifice	Dimensions (inches)			Set Pressure Range (PSIG)	Approx. Shipping Wt.	Max Temp. (°F)
			Height (A)	Hex (B)	Width (C)			
103H	1/4" NPT	0.25	3"	1-1/4"	3/4"	5-500	5 oz.	250 °F

### Materials

No.	Part Name	Materials
1	Body	Brass
2	Base	Brass
3	Cap	Brass
4	Stem Assembly, Item No. 6 & 10	
5	Adjusting Screw	Brass
6	Stem	Brass
7	Spring	Stainless Steel
8	Gasket	Com'l Copper
9	Lock Nut	Brass
10	Disc (Stem)	Viton

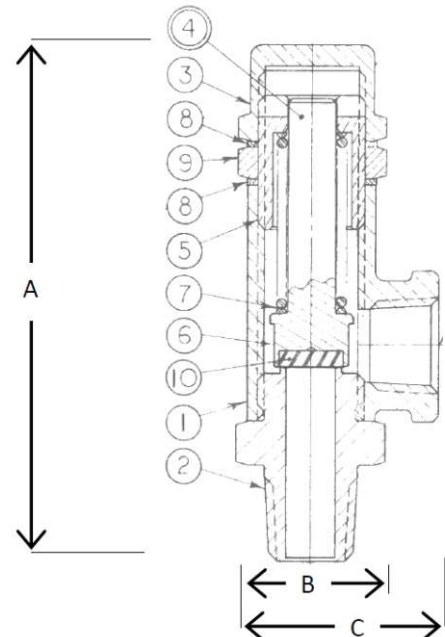

# Kingston Model 103H Side Relief Outlet Valve, Soft Seat

## Flow Capacity Information

Fig. 103H - 1/4"

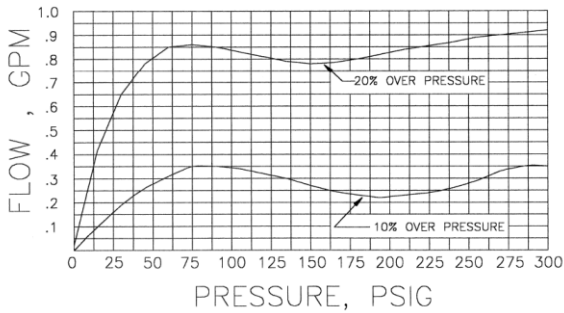
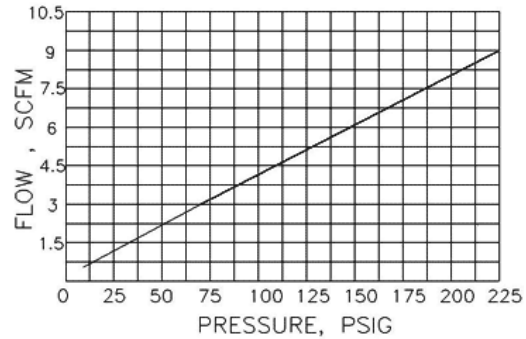
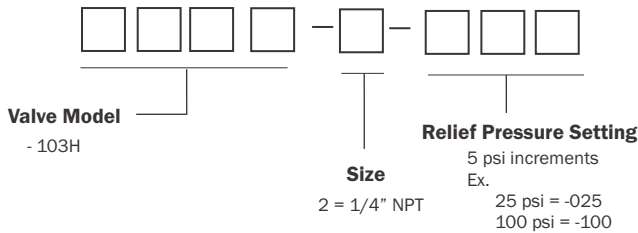

Fig. 103H - 1/4"



## Ordering Information

### Kingston Safety Relief Valve Part Number Codes



## Product Notes

All Kingston Safety Valves are manufactured under a quality control system accepted by the National Board of Boiler and Pressure Vessel inspectors. Code valves are capacity certified by the National Board, manufactured in accordance with ASME Code, set and sealed at the factory.

Set pressure can deviate from the marked by  $\pm 2$  psig at or below 70 psig set pressures and  $\pm 3\%$  psig above 70 psig.

Factory standard seat tightness for hard seat valves: no audible leakage at 20% below nameplate set. It is normal for spring-operated safety valves to exhibit leakage or simmer/warn, as the system operating pressure approaches the set pressure. For hard seat valves this is typically occurs at pressure at or above 80% of nameplate set pressure.

At very low set pressure (20 psig and below), the ratio of the downward spring force as compared to the upward pressure force is very small. In these cases it may be impossible to achieve seat tightness.

Soft seat valves will typically provide a higher degree of seat tightness than metal, hard seats. Factory standard seat tightness does not ensure bubble-tight seal regardless of material. Storm Manufacturing reserves all rights. Product specifications are subject to change without notice.

The information contained herein by Storm Manufacturing Group (SMG) is provided in good faith and as a product guide only. Further, SMG makes no representation as to the completeness or accuracy of the information contained herein. Any person or persons using the information contained herein must exercise their own judgement and consider all local, regional, national and global safety standards in evaluating valve selection options. Final application design and integration of Kingston Products are the sole responsibility of the end user.



www.KingstonValves.com  
**KINGSTON**