



North American
Safety Valve
Industries, Inc.



35,000 Safety & Relief Valves
Ready to Ship

When the pressure is on, trust North American Safety Valve Industries

We're Always on Standby

When you're under pressure, NASVI's ready to help.



New & Remanufactured Safety Valves

Extensive stock of new valves from trusted, top manufacturers and dependable remanufactured valves back by a 2-year warranty.



Same or Next-Day Shipping

Avoid or minimize downtime with NASVI's same or next-day shipping.



State-of-the-Art Repair & Setting Centers

Nearly every safety valve's specifications are at our technicians' fingertips for exact work. Generally, irreparable valves can be replaced from our in-stock inventory.



Turnaround Exchange Program

Receive the valves needed for installation prior to shutting down, then ship us the old valves for repair or exchange.

Get an Instant Quote

nasvi.com/quote

1600 Warren St.
North Kansas City, MO 64116

Phone: (800) 800-8882

Phone: (816) 421-7042

Fax: (816) 421-0297

sales@nasvi.com

spec sheet



CROSBY H-SERIES
DIRECT SPRING SAFETY VALVES

Direct spring safety valves that provide comprehensive overpressure protection for ASME Boiler and Pressure Vessel Code Section I, and Section VIII steam safety applications

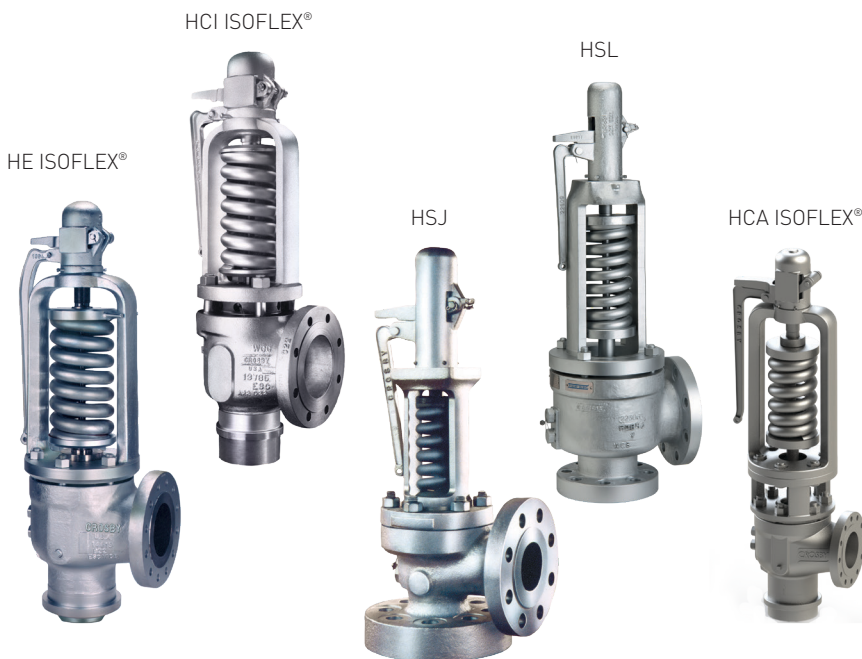

FEATURES

- ASME/NB certified capacities for steam.
- Set and tested on steam.
- Full nozzle flanged option.
- Restricted lift for customized capacity.
- Long service life.
- Low maintenance.
- Two ring set pressure and blowdown control.
- ISOFLEX seat tightness up to 93%. For seat tightness greater than 93% consult factory.

GENERAL APPLICATION

H-Series direct spring operated safety valves are the proven solution for comprehensive overpressure protection on steam safety applications including economizers, steam drums, superheaters, reheaters and more.

TECHNICAL DATA

Sizes:	1¼" F 1½" to 6" RR 10"
Orifices:	0.307 to 19.29 in ² (1.98 to 124.45 cm ²)
Connections:	Flanged or welded inlet
Temperature range:	1130°F (610°C)
Set pressures:	15 to 6200 psig (1 to 427 barg)
Code:	ASME Boiler and Pressure Vessel Code Section I, and Section VIII

CROSBY H-SERIES

DIRECT SPRING SAFETY VALVES

CONTENTS

Application Selection Matrix	2	Sizing	
Specifications		Sizing ASME Section I safety valves.....	72 - 73
Style HE ISOFLEX®	3 - 6	Pressure-temperature limits (ASME/ANSI B16.34).....	74 - 77
Style HCI, HCI-R ISOFLEX®	7 - 20	Outlet reaction forces.....	78 - 81
Style HSJ	21 - 30	Outlet reaction forces Style HSL	82
Style HSL	31 - 38	Options	
Style HCA-I	39 - 41	Optional equipment	83 - 84
Capacities		Ordering information.....	85 - 88
Saturated steam capacity tables (Styles HE, HCI and HSJ).....	42 - 57	Safety valve installation recommendations	89 - 91
Saturated steam capacity tables (Style HSL).....	58 - 61	Pressure relief device sizing and selection software.....	92
Superheat correction factor.....	62 - 63		
Steam capacity tables (Style HCA-I).....	64 - 71		

APPLICATION

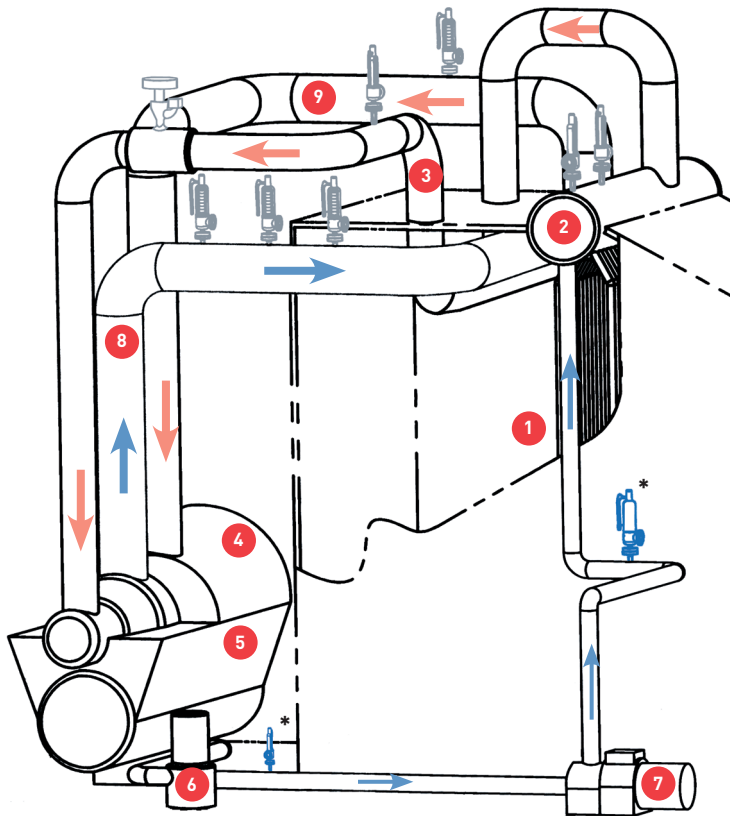

Complete overpressure protection for ASME B&PVC Section I

A complete safety valve package for utility and industrial steam generators and steam systems.

- Boilers with design pressures to 3100 psig (214 barg).
- Valves designed to increase plant up-times, extend maintenance intervals and increase total valve life.

Steam System Components

1. Furnace
2. Drum
3. Superheater outlet
4. Turbine
5. Condenser
6. Condensate pump
7. Boiler feed water pump
8. Cold reheat inlet
9. Hot reheat outlet



* A complete line of ASME Section VIII 'off-boiler' safety and pressure relief valves is available. Contact your local sales representative.

VALVE SELECTION

APPLICATIONS AND RECOMMENDED^[1] VALVE SELECTION

Steam system	Crosby valve style, design pressure - psig (barg)			
	15-600 [1-41]	300-2000 [21-138]	2001-3100 ^[2] [139-214]	3001-6200 [207-427]
Drum	HSJ/HSL	HCI	HE	-
Superheater outlet	HSJ/HSL	HCI	HCI	HCA-I
Reheater inlet	HSJ	HCI	HCI	-
Reheater outlet	HSJ	HCI	HCI	-
Economizer (Section I)	HSJ	HSJ	HSJ	-

NOTES

1. Selection matrix shows valves in optimum locations - Styles HSJ and HCI may be interchanged to suit a specific application or to obtain a more economical selection.
2. For supercritical applications, consult your sales representative.

CROSBY H-SERIES

STYLE HE ISOFLEX DIRECT SPRING SAFETY VALVE

STYLE HE ISOFLEX®

Style HE ISOFLEX® safety valves are high pressure, high capacity reaction type valves designed specifically for saturated steam service on boiler drums with design pressures above 2000 psig (138 barg) up to critical pressure.

FEATURES

- Extends Up-time
 - ISOFLEX® seat tightness to 93% of set pressure ensures maximum generating times, extending maintenance intervals.
 - For seat tightness greater than 93% consult factory.
- Reduces Maintenance Costs
 - Exceptional seat tightness minimizes maintenance resources and repair times and reduces spare parts purchase and inventory costs.
- Easily Adjustable for ASME Boiler and Pressure Vessel Code Section I Requirements
 - Advanced trim design with backpressure assist closing feature and patented eductor control eliminates complex adjustments to obtain ASME Boiler and Pressure Vessel Code Section I required blowdown.
- Minimizes Installation Costs
 - Weld end valves shipped as two assemblies to minimize installation time and labor and no special vent discharge piping is required, saving costs.
- Installation and Maintenance Efficiencies
 - Packaging designed for quick and easy installation.
 - Ease of adjustment and maintenance with fewer parts.
 - Two-ring blowdown control is easy to set and adjustable in the field.

TECHNICAL DATA

Sizes:	2½" x 6" to 4" x 8" (DN 65 x DN 150 to DN 100 x DN 200)
Orifices:	1.840 to 7.070 in ² (11.87 to 45.61 cm ²)
Connections:	ANSI flanged or butt weld inlet and ANSI flanged outlet
Maximum temperature:	Up to 750°F (399°C)
Maximum set pressure:	Up to 3060 psig (211 barg)
Code:	ASME Boiler and Pressure Vessel Code Section I



CROSBY H-SERIES

STYLE HE ISOFLEX

PRODUCT OVERVIEW

The HE ISOFLEX incorporates our latest field proven seat tightness design which allows boilers to operate close to set pressure without leakage across the valve seat. The HE ISOFLEX also has a unique patented eductor control that permits the valve to attain full capacity lift at a pressure 3% above popping pressure to the requirements of Section I of the ASME Boiler and Pressure Vessel Code.

APPLICATION

The HE ISOFLEX safety valve is a high pressure, high capacity reaction type valve, designed specifically for saturated steam service on boiler drums having design pressures above 2000 psig (138 barg) up to critical pressure.

LOW FRICTION SET POINT ADJUSTMENT

Springs on drum safety valves have very high preloads. A thrust bearing (25) between the adjusting bolt (26) and top spring washer (21) makes set point adjustments precise and keeps friction torque low. The valve seats are protected from damage during set point adjustment by lugs on the upper spring washer (21) which engage the bonnet (17) to prevent rotation of the spring (20), spindle (12) and disc insert (5).

PRECISE POPPING AND BLOWDOWN ACTION

A dual-stage, controlled flow passage is formed by the eductor (9), disc holder (6) and the adjustable guide ring (10).

These flow passages co-act with the apertured guide ring to control the flow of steam to a chamber above the disc holder (6). Changes in chamber pressure plus the action of other internal parts ensure full opening without warning and also assist in positive blowdown of between 2% and 4%, as required by ASME I code, which is obtained by adjusting the guide ring. The adjustable nozzle ring (3) ensures accurate, warn-free and sharp pop action on opening.

TIGHT SHUT-OFF WITH ISOFLEX® DESIGN

The seat-level loading of the spindle (12) on the disc insert (5) ensures uniform seat-loading. The seating region of the ISOFLEX® disc insert is recessed for pressure loading and temperature equalization ensuring maximum seat tightness.

OPERATION

As pressure in the boiler increases to the safety valve set point, the valve will pop open. Steam then passes through a series of flow passages (A) and (B) which control the pressure developed in chambers (C) and (D), the excess steam exhausting through guide ring openings (E) to the valve body bowl (F).

As pressure in the boiler drops, the dynamic forces on the lower face of the disc holder assembly are reduced and the safety valve disc begins to close. Assisted by pressure in chambers (C) and (D), the valve at this point closes sharply and tightly.

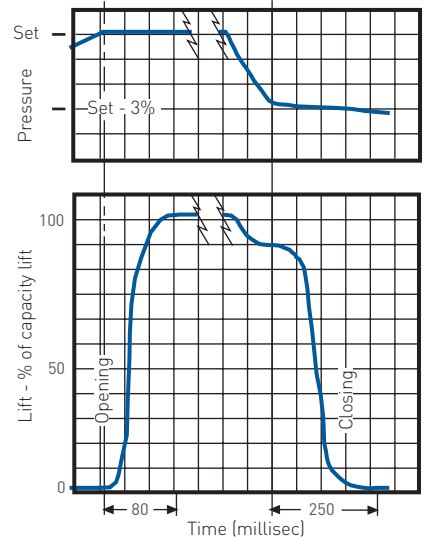
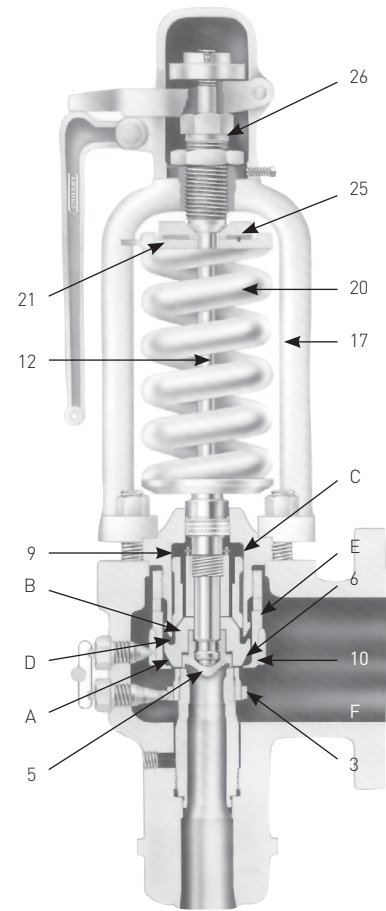

Typical valve opening and closing curve

CROSBY H-SERIES

STYLE HE ISOFLEX

MATERIALS

Part ref. no.	Part name	Material	Spare parts designation ^[1,2,3]
1A	Body	Carbon steel SA-216 Gr. WCC	
1B	Nozzle	Stainless steel	
3	Nozzle ring	Stainless steel	3
4	Nozzle ring set screw	Stainless steel	
5	Disc insert	Inconel®	1
6	Disc holder	Nickel alloy	2
7	Disc holder retaining nut	Stainless steel	
9	Eductor	Nickel alloy	2
10	Guide ring	Stainless steel	3
11	Guide ring set screw	Stainless steel	
12	Spindle assembly	Stainless steel	2
13	Piston	Nickel alloy	
14	Piston retaining ring	Steel	2
15	Spindle nut	Steel	
17	Bonnet	Carbon steel SA-216 Gr. WCC	
18	Bonnet studs	Alloy steel SA-193 Gr. B7	
19	Bonnet stud nuts	Steel SA-194 Gr. 2H	
20	Spring	Alloy steel	
		Corrosion resistant coating	
21	Bottom spring washer	Steel	
22	Top spring washer	Steel	
24	Bearing adapter	Alloy steel	
25	Thrust bearing	Commercial	
26	Adjusting bolt	Stainless steel	
27	Adjusting bolt nut	Steel	
28	Cap	Steel/iron	
30	Lever	Steel/iron	
31	Lever pin	Steel	
33	Forked lever	Steel/iron	
34	Forked lever pin	Steel	

A complete set of spare cotter pins (not listed above) is also recommended for proper maintenance of the valve

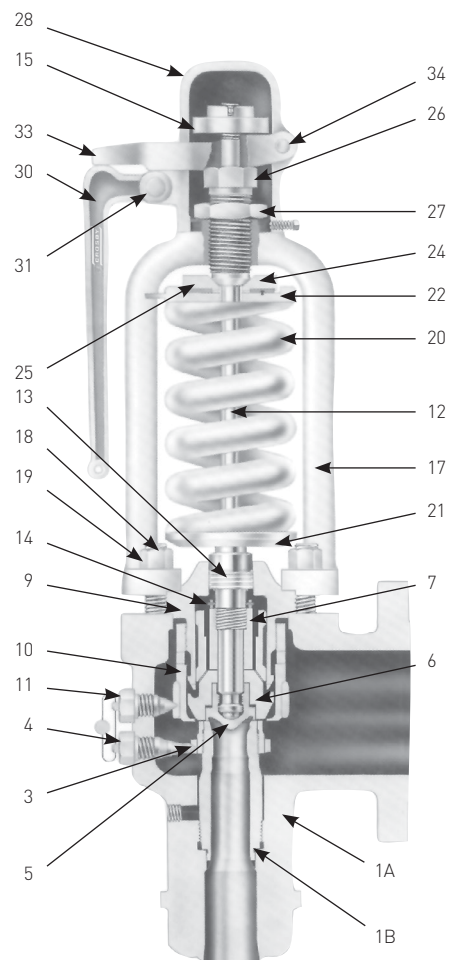

NOTES

- Consumable spare parts: valve parts which should be replaced as part of any disassembly. (Disc inserts must be replaced if seats are severely damaged)
- Repair spare parts: valve parts exposed to wear and/or corrosion during normal operation. They are in fluid flow paths and may require replacement as part of any repair.
- Insurance spare parts: valve parts exposed to process or environmental wear and/or corrosion and may require replacement as part of a major repair.

Emerson recommends that sufficient inventory of spare parts be maintained to support process requirements. Always be sure to use genuine Crosby parts to ensure continued product performance and warranty.

For information on installation and care, refer to Instruction No. IS-V3155B, 'Installation, Operating and Maintenance Instruction for Crosby Style HE Design III Self-Actuated Safety Valves'.

CROSBY H-SERIES

STYLE HE ISOFLEX

STYLE HE ISOFLEX® - DIMENSIONS AND WEIGHTS

USCS (UNITED STATES CUSTOMARY SYSTEM) UNITS

Valve size inlet x orifice x outlet	HE valve style ⁽¹⁾	Orifice area sq. in. (sq. mm)	Connections in. (mm)		Dimensions in. (mm)								Approx. height ⁽⁴⁾ in. (mm)		Approx. weight lbs. (kg)	
			Butt weld inlet	ANSI Class flanged outlet	Inlet ID		Bw ⁽²⁾ inlet O.D.	Center to face of				Ew	E	Welded	Flanged	
					Aw ⁽²⁾	A		Inlet Cw	C	Outlet ⁽³⁾ Dw	D					
2500 psig maximum pressure																
2½ K 6	HE-86W	1.840	2½	6"-300	2½	2½	5¼	11	8¼	8½	8½	36 ¹⁵ / ₁₆	34 ³ / ₁₆	350	375	
2½ K2 6	HE-86W	2.545	2½	6"-300	2½	2½	6	12	8 ¹³ / ₁₆	8½	8½	44¼	41 ¹ / ₁₆	410	435	
3 M 6	HE-86W	3.600	3	6"-300	3	3	8	12	8 ⁷ / ₈	10	10	49½	46 ³ / ₈	630	625	
3 M26	HE-86W	3.976	3	6"-300	3	3	8	12	8 ⁷ / ₈	10	10	49 ⁷ / ₈	46 ³ / ₄	630	625	
4 P2 8	HE-86W	7.070	4	8"-300	4	4	9	13¼	14½	13	13	64	65	1100	1185	

3060 psig maximum pressure

2½ K 6	HE-96W	1.840	2½	6"-300	2½	2½	5¼	11	8¼	8½	8½	36 ¹⁵ / ₁₆	34 ³ / ₁₆	350	375
2½ K2 6	HE-96W	2.545	2½	6"-300	2½	2½	6	12	8 ¹³ / ₁₆	8½	8½	44¼	41 ¹ / ₁₆	410	435
3 M 6	HE-96W	3.600	3	6"-300	3	3	8	12	8 ⁷ / ₈	10	10	49½	46 ³ / ₈	630	635
3 M26	HE-96W	3.976	3	6"-300	3	3	8	12	8 ⁷ / ₈	10	10	49 ⁷ / ₈	46 ³ / ₄	630	635
4 P28	HE-96W	7.070	4	8"-300	4	4	9	13¼	14½	13	13	64	65	1100	1185

METRIC UNITS

172 barg maximum pressure

2½ K 6	HE-86W	1187.1	63.5	6"-300	63.5	63.5	133	279	210	216	216	938	868	159	170
2½ K2 6	HE-86W	1641.9	63.5	6"-300	63.5	63.5	152	305	224	216	216	1124	1043	186	193
3 M 6	HE-86W	2322.6	76.2	6"-300	76.2	76.2	203	305	225	254	254	1257	1178	286	284
3 M26	HE-86W	2565.2	76.2	6"-300	76.2	76.2	203	305	225	254	254	1267	1187	286	284
4 P2 8	HE-86W	4560.4	101.6	8"-300	101.6	101.6	229	337	368	330	330	1626	1651	499	538

211 barg maximum pressure

2½ K 6	HE-96W	1187.1	63.5	6"-300	63.5	63.5	133	279	210	216	216	938	868	159	170
2½ K2 6	HE-96W	1641.9	63.5	6"-300	63.5	63.5	152	305	224	216	216	1124	1043	186	193
3 M 6	HE-96W	2322.6	76.2	6"-300	76.2	76.2	203	305	225	254	254	1257	1178	286	284
3 M26	HE-96W	2565.2	76.2	6"-300	76.2	76.2	203	305	225	254	254	1267	1187	286	284
4 P2 8	HE-96W	4560.4	101.6	8"-300	101.6	101.6	229	337	368	330	330	1626	1651	499	538

NOTES

- These style designations are for standard welded inlets. For optional CL 2500 flanged inlet valves, the "W" is dropped from the style designation.
 - Weld prep per customer's specifications. Safety valves must be mounted on a nozzle with an inlet diameter equal to or greater than the nominal valve inlet size, dimension A. See ASME boiler and pressure vessel code Section I and ANSI/ASME B31.1 for recommended installation.
 - Bolt holes straddle centerline on flanged connections.
 - Dismantling height: an additional 20 inches (508 mm) is required.
- Drain: main valve drain is ½" NPT.

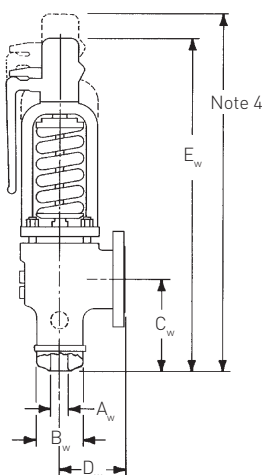
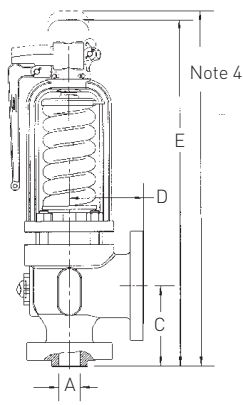

CROSBY H-SERIES

STYLE HCI ISOFLEX DIRECT SPRING SAFETY VALVE

STYLE HCI ISOFLEX®

Style HCI ISOFLEX® has been designed for 300 to 3100 psig (21 to 214 barg) steam generators for use on drum service, superheater outlets, reheater inlets and outlets.

FEATURES

- Increases Operating Efficiency
 - Restricted Lift Option for customized capacity, reduced reaction forces, and boiler design standardization
 - Seat tightness up to 93% of valve set pressure. For seat tightness greater than 93% consult factory
 - Two ring control to adjust overpressure and blowdown independently
 - May also be used for ASME Boiler and Pressure Vessel Code Section VIII off boiler steam applications for higher operating pressures
- Reduces Maintenance Costs
 - Interchangeable spare parts minimizes inventory levels
 - Higher nozzle seat step to extend valve service life
- Minimizes Installation Costs
 - Packaging designed for quick and easy installation
 - Easy to set and adjust set pressure while in service

TECHNICAL DATA

Sizes:	1½" x 3" to 6" x 10" (DN 40 x DN 80 to DN 150 x DN 250)
Orifices:	0.994 to 19.29 in ² (6.41 to 124.45 cm ²)
Connections:	ANSI flanged or butt weld inlet and ANSI flanged outlet
Maximum temperature:	1130°F (610°C)
Maximum set pressure:	3100 psig (214 barg)
Codes:	ASME Boiler and Pressure Vessel Code Section I, and Section VIII



CROSBY H-SERIES

STYLE HCI ISOFLEX

PRODUCT OVERVIEW

The HCI ISOFLEX safety valve is a high capacity nozzle type valve suitable for saturated and superheated steam service. The valves are available in inlet sizes of 1½", 2", 2½", 3", 4" and 6" and in orifice sizes H2 to RR specifically designed for the power industry. Welded inlets and flanged outlets are standard, with flanged inlets (1) with full (removable) nozzles (2) also available.

The valves' relieving capacities have been determined by tests conducted in accordance with ASME Boiler and Pressure Vessel Code Section I rules. They are certified by the National Board of Boiler and Pressure Vessel Inspectors and listed in their publication 'Pressure Relief Device Certifications.'

HIGH CAPACITY

The adjustable nozzle and guide rings (3 and 12) utilize the reactive and expansive forces of the flowing steam to provide full capacity lift. Valve capacity is determined by the nozzle (1B) throat area alone. With high capacity valves, positive overpressure protection is achieved with the fewest valves.

TIGHT SHUT-OFF

The seating region of the ISOFLEX® disc insert (5) is recessed for pressure and temperature equalization, ensuring that the seats remain flat in service.

TWO RING DESIGN

Blowdown control is precise with two adjustable rings (3 and 12) - one each on the nozzle (1B or 2) and guide (11). Blowdown may be adjusted from 2 to 4% under operating conditions.

PRECISE POPPING POINT

Close machining tolerances ensure that the disc insert (5) is centered precisely and special guide and disc/disc holder materials and surface finishes ensure low friction guiding at all temperatures. Spring specifications are held to rigid tolerances and stresses are kept within lowest practical limits. The open bonnet exposes the spring to atmosphere, minimizing thermal effects. The valves open precisely at their established set pressure, even after repeated cycling.

NOTE

Full (removable) nozzles not available in P2 (8" outlet) R and RR sizes.

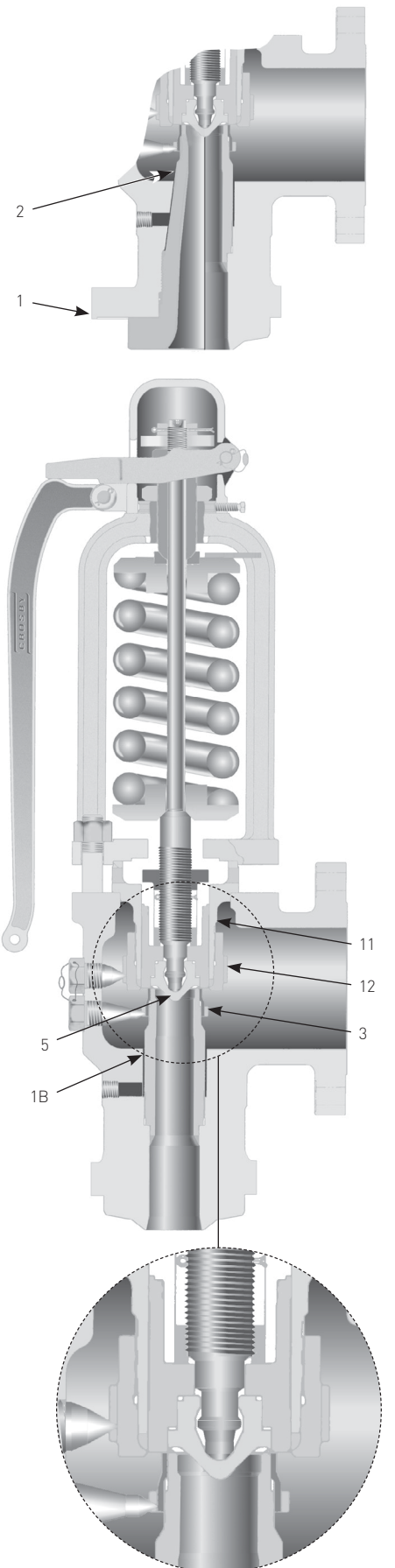

CROSBY H-SERIES

STYLE HCI ISOFLEX

MATERIALS

Part ref.	Part name	Material and maximum temperature			Spare parts designation ^[1,2,3]
		750°F (399°C)	1050°F (566°C)	1100°F (593°C)	
1A	Body	Carbon steel SA-216 Gr. WCC	Alloy steel SA-217 Gr. WC6	Alloy Steel*** SA-217 Gr. WC9	
1B*	Nozzle	Stainless steel	Stainless steel	Stainless steel	
2*	Nozzle	Stainless steel	Stainless steel	Stainless steel	3
3	Nozzle ring	Stainless steel	Stainless steel	Stainless steel	3
4	Nozzle ring set screw	Stainless steel	Stainless steel	Stainless steel	
5	Disc insert	Inconel®	Inconel®	Inconel®	1
6	Disc holder	Nickel alloy	Nickel alloy	Nickel alloy	2
7	Disc holder retainer	Stainless steel	Stainless steel	Stainless steel	
8**	Lift stop	Stainless steel	Stainless steel	Stainless steel	
9	Disc holder retainer cotter	Stainless steel	Stainless steel	Stainless steel	1
10**	Lift stop cotter	Stainless steel	Stainless steel	Stainless steel	1
11	Guide	Nickel alloy	Nickel alloy	Nickel alloy	2
12	Guide ring	Stainless steel	Stainless steel	Stainless steel	3
13	Guide ring set screw	Stainless steel	Stainless steel	Stainless steel	
14	Spindle assembly	Stainless steel	Stainless steel	Stainless steel	2
15	Spring	Alloy steel Corrosion resistant coating	High temp. Corrosion resistant coating	High temp. Alloy steel Corrosion resistant coating	
16	Bottom spring washer	Steel	Steel	Steel	
17	Top spring washer	Steel	Steel	Steel	
18	Bearing adapter	Alloy steel	Alloy steel	Alloy steel	
19	Thrust washer	Steel	Steel	Steel	
20	Bonnet	Carbon steel SA-216 Gr. WCC	Alloy steel SA-217 Gr. WC6	Alloy steel SA-217 Gr. WC6	
21	Bonnet studs	Alloy Steel SA-193 Gr. B7	Alloy steel SA-193 Gr. B16	Alloy steel SA-193 Gr. B16	
22	Bonnet stud nuts	Steel SA-194 Gr. 2H	Steel SA-194 Gr. 2H	Steel SA-194 Gr. 2H	
23	Adjusting bolt	Stainless steel	Stainless steel	Stainless steel	
24	Adjusting bolt nut	Stainless steel	Stainless steel	Stainless steel	
25	Cap/lever assembly	Steel/iron	Steel/iron	Steel/iron	
33	Spindle nut	Stainless steel	Stainless steel	Stainless steel	
34	Spindle nut cotter	Stainless steel	Stainless steel	Stainless steel	1
35	Seal and wire	Lead and SS	Lead and SS	Lead and SS	

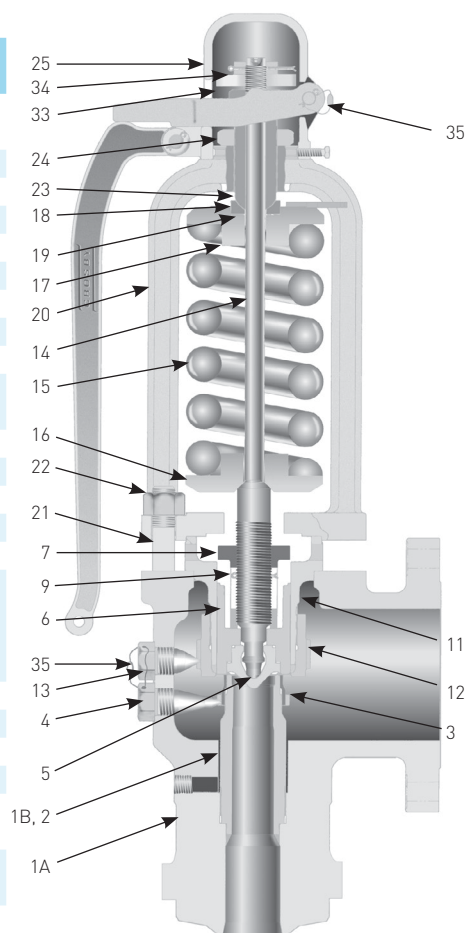

* Semi-nozzle design for welded inlet and P2 (8" outlet), R and RR orifice flanged inlet valves. Full nozzle design for remaining H2 through Q2 orifice flanged inlet valves.

Inconel 625 nozzle available for high temperature applications

** Restricted lift valve (HCI-R) part only (see page 18).

*** SA-217 Gr. WC9 is Crosby's standard high temperature material.
SA-217 Gr. C12A is available as an alternative.

NOTES

1. Consumable spare parts: valve parts which should be replaced as part of any disassembly, and discs and disc inserts which must be replaced if seats are damaged.
2. Repair spare parts: valve parts exposed to wear and/or corrosion during normal operation. They are in fluid flow paths and may require replacement as part of any repair.
3. Insurance spare parts: valve parts exposed to process or environmental wear and/or corrosion and may require replacement as part of a major repair.

Emerson recommends that sufficient inventory of spare parts be maintained to support process requirements. Always be sure to use genuine Crosby parts to ensure continued product performance and warranty.

For information on installation and care, refer to instruction No. IS-V3143A, 'Installation, maintenance and adjustment instruction for Crosby style HCI ISOFLEX® safety valves'.

CROSBY H-SERIES

STYLE HCI-R ISOFLEX

STYLE HCI-R ISOFLEX®

Restricted lift feature

A restricted lift option is available on all HCI ISOFLEX® valve sizes with either flanged or weld end connections.

Style HCI-R's capacities may be adjusted from 100% to 30% of full rated capacity.

Restricted capacity = (% of restricted lift) x (ASME rated capacity).

- Eliminating over-capacity permits an economic distribution of relieving capacity between the drum and superheater valves, often resulting in a smaller superheater safety valve selection.
- Reduces reaction forces.
- Standardization of valve sizes allows boiler manufacturers to build standard boilers.
- Quality and performance assured via tamper-proof installation that prevents erroneous changes in capacity.

NOTE

For information on installation and care, see instruction No. IS-V3143A, 'Installation, maintenance and adjustment instruction for Crosby style HCI ISOFLEX® safety valves'.

HCI-R ISOFLEX®

Part ref. no.	Part name	Material
7	Disc holder retainer	Stainless steel
8	Lift stop	Stainless steel
9	Disc holder retainer cotter	Stainless steel
10	Lift stop cotter	Stainless steel

Complete list of parts and materials on page 9.

STYLE HCI ISOFLEX®

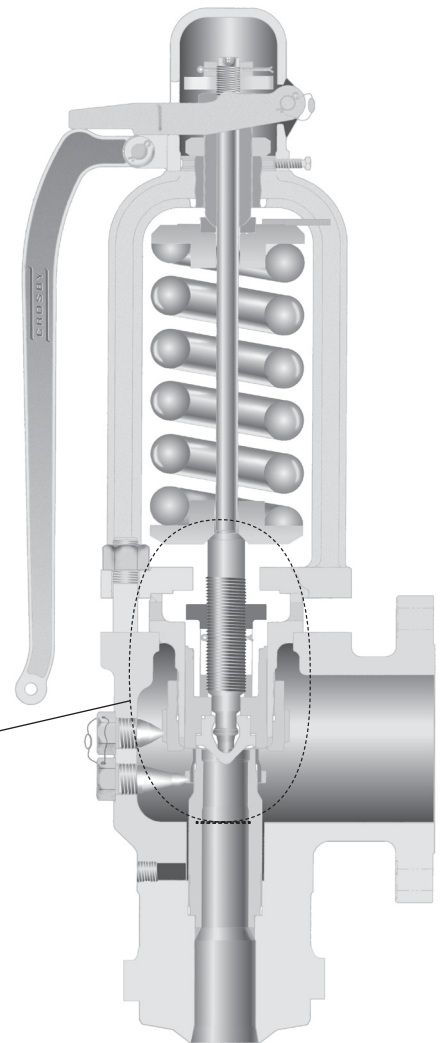

STYLE HCI-R ISOFLEX® (RESTRICTED LIFT)

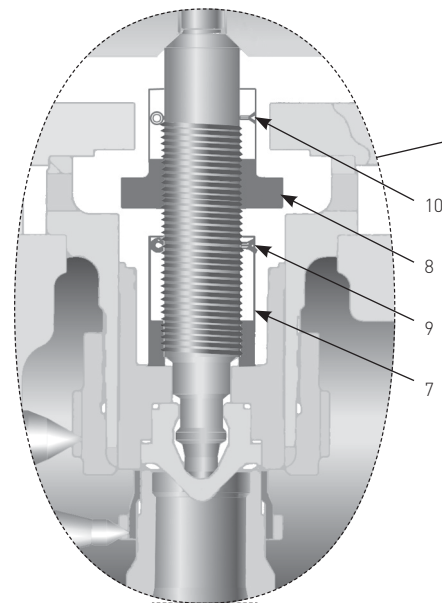

CROSBY H-SERIES

STYLE HCI ISOFLEX

STYLE HCI ISOFLEX® - PRESSURE AND TEMPERATURE LIMITS*

USCS (UNITED STATES CUSTOMARY SYSTEM) UNITS

Valve Size Inlet x Orifice x Outlet	Orifice Area (sq. in.)	Inlet Type	Class 300 - ANSI raised face flange or welded CL 300 inlet														Optional Flanged Outlet Class	Optional Flanged Outlet Class
			Body Material and Temperature															
			SA216 Gr. WCC -100 to 500°F	SA216 Gr. WCC 600°F	SA216 Gr. WCC 650°F	SA216 Gr. WCC 700°F	SA216 Gr. WCC 750°F	SA217 Gr. WC6 800°F	SA217 Gr. WC6 850°F	SA217 Gr. WC6 900°F	SA217 Gr. WC6 950°F	SA217 Gr. WC6 1000°F	SA217 Gr. WC6 1050°F	SA217 Gr. WC9 1100°F	SA217 Gr. C12A 1100°F	SA217 Gr. C12A 1130°F		
			HCI-36	HCI-36	HCI-36	HCI-36	HCI-36	HCI-38	HCI-38	HCI-38	HCI-38	HCI-38	HCI-38	-	-	-		
1½ H2 3	0.994	Flange	665	605	590	555	505	510	485	450	320	215	145	-	-	-	3" Cl 150	3" Cl 300
		ButtWeld	665	665	665	665	665	665	665	665	665	665	665	665	-	-		
2 J2 4	1.431	Flange	665	605	590	555	505	510	485	450	320	215	145	-	-	-	4" Cl 150	4" Cl 300
		ButtWeld	665	665	665	665	665	665	665	665	665	665	665	665	-	-		
2½ K2 6	2.545	Flange	665	605	590	555	505	510	485	450	320	215	145	-	-	-	6" Cl 150	6" Cl 300
		ButtWeld	665	665	665	665	665	665	665	665	665	665	665	665	-	-		
3 L2 6	3.341	Flange	665	605	590	555	505	510	485	450	320	215	145	-	-	-	6" Cl 150	6" Cl 300
		ButtWeld	665	665	665	665	665	665	665	665	665	665	665	665	-	-		
3 M2 6	3.976	Flange	665	605	590	555	505	510	485	450	320	215	145	-	-	-	6" Cl 150	6" Cl 300
		ButtWeld	665	665	665	665	665	665	665	665	665	665	665	665	-	-		
4 P2 6	7.070	Flange	665	605	590	555	505	510	485	450	320	215	145	-	-	-	6" Cl 300	-
		ButtWeld	665	665	665	665	665	665	665	665	665	665	665	665	-	-		
6 Q2 8	12.250	Flange	665	605	590	555	505	510	485	450	320	215	145	-	-	-	8" Cl 300	-
		ButtWeld	665	665	665	665	665	665	665	665	665	665	665	665	-	-		
6 R 8	16.000	Flange	665	605	590	555	505	510	485	450	320	215	145	-	-	-	8" Cl 300	-
		ButtWeld	665	665	665	665	665	665	665	665	665	665	665	665	-	-		
6 RR 10	19.290	Flange	665	605	590	555	505	510	485	450	320	215	145	-	-	-	10" Cl 300	-
		ButtWeld	665	665	665	665	665	665	665	665	665	665	665	665	-	-		

Valve Size Inlet x Orifice x Outlet	Orifice Area (sq. in.)	Inlet Type	Class 600 - ANSI raised face flange or welded CL 600 inlet														Standard Flanged Outlet Class	Optional Flanged Outlet Class
			Body Material and Temperature															
			SA216 Gr. WCC -100 to 600°F	SA216 Gr. WCC 650°F	SA216 Gr. WCC 700°F	SA216 Gr. WCC 750°F	SA217 Gr. WC6 800°F	SA217 Gr. WC6 850°F	SA217 Gr. WC6 900°F	SA217 Gr. WC6 950°F	SA217 Gr. WC6 1000°F	SA217 Gr. WC6 1050°F	SA217 Gr. WC9 1100°F	SA217 Gr. C12A 1100°F	SA217 Gr. C12A 1130°F			
			HCI-46	HCI-46	HCI-46	HCI-46	HCI-48	HCI-48	HCI-48	HCI-48	HCI-48	HCI-48	-	-	-			
1½ H2 3	0.994	Flange	1210	1175	1110	1015	1015	975	900	640	430	290	-	-	-	3" Cl 150	3" Cl 300	
		ButtWeld	1250	1250	1250	1250	1250	1250	1250	1250	1250	1250	1250	1250	-			-
2 J2 4	1.431	Flange	1210	1175	1110	1015	1015	975	900	640	430	290	-	-	-	4" Cl 150	4" Cl 300	
		ButtWeld	1250	1250	1250	1250	1250	1250	1250	1250	1250	1250	1250	1250	-			-
2½ K2 6	2.545	Flange	1210	1175	1110	1015	1015	975	900	640	430	290	-	-	-	6" Cl 150	6" Cl 300	
		ButtWeld	1250	1250	1250	1250	1250	1250	1250	1250	1250	1250	1250	1250	-			-
3 L2 6	3.341	Flange	1210	1175	1110	1015	1015	975	900	640	430	290	-	-	-	6" Cl 150	6" Cl 300	
		ButtWeld	1250	1250	1250	1250	1250	1250	1250	1250	1250	1250	1250	1250	-			-
3 M2 6	3.976	Flange	1210	1175	1110	1015	915	857	813	640	430	290	-	-	-	6" Cl 150	6" Cl 300	
		ButtWeld	1250	1250	1250	1250	1250	1250	1250	1250	1250	1250	1250	1250	-			-
4 P2 6	7.070	Flange	1210	1175	1110	1015	1015	975	900	640	430	290	-	-	-	6" Cl 300	-	
		ButtWeld	1250	1250	1250	1250	1250	1250	1250	1250	1250	1250	1250	1250	-			-
6 Q2 8	12.250	Flange	1210	1175	1110	1015	1015	975	900	640	430	290	-	-	-	8" Cl 300	-	
		ButtWeld	1250	1250	1250	1250	1250	1250	1250	1250	1250	1250	1250	1250	-			-
6 R 8	16.000	Flange	750	750	750	750	750	750	750	640	430	290	-	-	-	8" Cl 300	-	
		ButtWeld	750	750	750	750	750	750	750	750	750	750	750	750	-			-
6 R 10	16.000	Flange	900	900	900	900	900	900	900	640	430	290	-	-	-	10" Cl 300	-	
		ButtWeld	900	900	900	900	900	900	900	900	900	900	900	900	-			-
6 RR 10	19.290	Flange	900	900	900	900	900	900	900	640	430	290	-	-	-	10" Cl 300	-	
		ButtWeld	900	900	900	900	900	900	900	900	900	900	900	900	-			-

* Select appropriate class to meet pressure/temperature requirements for each application.
Refer to pages 74-77 for pressure/temperature limits for standard class valves per ASME/ANSI B16.34.

CROSBY H-SERIES

STYLE HCI ISOFLEX

STYLE HCI ISOFLEX® - PRESSURE AND TEMPERATURE LIMITS*

USCS (UNITED STATES CUSTOMARY SYSTEM) UNITS

Valve Size Inlet x Orifice x Outlet	Orifice Area (sq. in.)	Inlet Type	Class 900 - ANSI raised face flange or welded CL 900 inlet														Standard Flanged Outlet Class	Optional Flanged Outlet Class	
			Body Material and Temperature																
			SA216 Gr. WCC -100 to 600°F	SA216 Gr. WCC 650°F	SA216 Gr. WCC 700°F	SA216 Gr. WCC 750°F	SA217 Gr. WC6 800°F	SA217 Gr. WC6 850°F	SA217 Gr. WC6 900°F	SA217 Gr. WC6 950°F	SA217 Gr. WC6 1000°F	SA217 Gr. WC6 1050°F	SA217 Gr. WC9 1100°F	SA217 Gr. C12A 1100°F	SA217 Gr. C12A 1130°F				
			HCI-56	HCI-56	HCI-56	HCI-56	HCI-58	HCI-58	HCI-58	HCI-58	HCI-58	HCI-58	HCI-58	HCI-58	HCI-59W	HCI-59W -C12A	HCI-59W -C12A		
1½ H2 3	0.994	Flange ButtWeld	1500 1500	1500 1500	1500 1500	1500 1500	1500 1500	1460 1500	1350 1500	955 1500	650 1500	430 1500	- 1500	- 1500	- 1500	- 1500	- 1500	3" Cl 150	3" Cl 300
2 J2 4	1.431	Flange ButtWeld	1500 1500	1500 1500	1500 1500	1500 1500	1500 1500	1460 1500	1350 1500	955 1500	650 1500	430 1500	- 1500	- 1500	- 1500	- 1500	- 1500	4" Cl 150	4" Cl 300
2½ K2 6	2.545	Flange ButtWeld	1500 1500	1500 1500	1500 1500	1500 1500	1500 1500	1460 1500	1350 1500	955 1500	650 1500	430 1500	- 1500	- 1500	- 1500	- 1500	- 1500	6" Cl 150	6" Cl 300
3 L2 6	3.341	Flange ButtWeld	1500 1500	1500 1500	1500 1500	1500 1500	1500 1500	1460 1500	1350 1500	955 1500	650 1500	430 1500	- 1500	- 1500	- 1500	- 1500	- 1500	6" Cl 150	6" Cl 300
3 M2 6	3.976	Flange ButtWeld	1500 1500	1500 1500	1500 1500	1500 1500	1500 1500	1460 1500	1350 1500	955 1500	650 1500	430 1500	- 1498	- 1500	- 1500	- 1500	- 1500	6" Cl 150	6" Cl 300
4 P2 6	7.070	Flange ButtWeld	1500 1500	1500 1500	1500 1500	1500 1500	1500 1500	1460 1500	1350 1500	955 1500	650 1500	430 1276	- 949	- 1280	- 1104	- 1104	- 1104	6" Cl 300	-
6 Q2 8	12.250	Flange ButtWeld	1500 1500	1500 1500	1500 1500	1500 1500	1500 1500	1460 1500	1350 1500	955 1500	650 1500	430 1500	- 1383	- 1500	- 1500	- 1500	- 1500	8" Cl 300	-
6 R 8	16.000	Flange ButtWeld	900 900	900 900	900 900	900 900	900 900	900 900	900 900	900 900	650 900	430 900	- 900	- 900	- 900	- 900	- 900	8" Cl 300	-
6 R 10	16.000	Flange ButtWeld	1200 1200	1200 1200	1200 1200	1200 1200	1200 1200	1200 1200	1200 1200	955 1200	650 1200	430 1200	- 1200	- 1200	- 1200	- 1200	- 1200	10" Cl 300	-
6 RR 10	19.290	Flange ButtWeld	900 900	900 900	900 900	900 900	900 900	900 900	900 900	900 900	650 900	430 900	- 736	- 900	- 879	- 879	- 879	10" Cl 300	-
			Class 1500 - ANSI raised face flange or welded CL 1500 inlet																
			HCI-66	HCI-66	HCI-66	HCI-66	HCI-68	HCI-68	HCI-68	HCI-68	HCI-68	HCI-68	HCI-68	HCI-68	HCI-69W -C12A	HCI-69W -C12A			
1½ H2 3	0.994	Flange ButtWeld	1500 1500	1500 1500	1500 1500	1500 1500	1500 1500	1500 1500	1500 1500	1500 1500	1080 1500	720 1500	- 1500	- 1500	- 1500	- 1500	- 1500	3" Cl 150	3" Cl 300
2 J2 4	1.431	Flange ButtWeld	1500 1500	1500 1500	1500 1500	1500 1500	1500 1500	1500 1500	1500 1500	1500 1500	1080 1500	720 1500	- 1500	- 1500	- 1500	- 1500	- 1500	4" Cl 150	4" Cl 300
2½ K2 6	2.545	Flange ButtWeld	1500 1500	1500 1500	1500 1500	1500 1500	1500 1500	1500 1500	1500 1500	1500 1500	1080 1500	720 1500	- 1500	- 1500	- 1500	- 1500	- 1500	6" Cl 150	6" Cl 300
3 L2 6	3.341	Flange ButtWeld	1500 1500	1500 1500	1500 1500	1500 1500	1500 1500	1500 1500	1500 1500	1500 1500	1080 1500	720 1500	- 1500	- 1500	- 1500	- 1500	- 1500	6" Cl 150	6" Cl 300
3 M2 6	3.976	Flange ButtWeld	1500 1500	1500 1500	1500 1500	1500 1500	1500 1500	1500 1500	1500 1500	1500 1500	1080 1500	720 1500	- 1498	- 1500	- 1500	- 1500	- 1500	6" Cl 150	6" Cl 300
4 P2 6	7.070	Flange ButtWeld	1500 1500	1500 1500	1500 1500	1500 1500	1500 1500	1500 1500	1500 1500	1500 1500	1080 1500	720 1472	- 1087	- 1578	- 1303	- 1303	- 1303	6" Cl 300	-
6 Q2 8	12.250	Flange ButtWeld	1500 1500	1500 1500	1500 1500	1500 1500	1500 1500	1500 1500	1500 1500	1500 1500	1080 1500	720 1500	- 1390	- 1500	- 1500	- 1500	- 1500	8" Cl 300	-
6 R 8	16.000	Flange ButtWeld	1500 1500	1500 1500	1500 1500	1500 1500	1500 1500	1500 1500	1500 1500	1500 1500	1080 1500	720 1226	- 1018	- 1409	- 1221	- 1221	- 1221	8" Cl 300	-
6 R 10	16.000	Flange ButtWeld	1500 1500	1500 1500	1500 1500	1500 1500	1500 1500	1500 1500	1500 1500	1500 1500	1080 1500	720 1500	- 1330	- 1864	- 1599	- 1599	- 1599	10" Cl 300	-
6 RR 10	19.290	Flange ButtWeld	1500 1500	1500 1500	1500 1500	1500 1500	1500 1500	1500 1500	1500 1500	1500 1500	1080 1500	720 1500	- 1174	- 1500	- 1406	- 1406	- 1406	10" Cl 300	-

* Select appropriate class to meet pressure/temperature requirements for each application.
Refer to pages 74-77 for pressure/temperature limits for standard class valves per ASME/ANSI B16.34.

CROSBY H-SERIES

STYLE HCI ISOFLEX

STYLE HCI ISOFLEX® - PRESSURE AND TEMPERATURE LIMITS*

USCS (UNITED STATES CUSTOMARY SYSTEM) UNITS

Valve Size Inlet x Orifice x Outlet	Orifice Area (sq. in.)	Inlet Type	Class 900 - ANSI raised face flange or welded CL 900 inlet														Standard Flanged Outlet Class	Optional Flanged Outlet Class	
			Body Material and Temperature																
			SA216 Gr. WCC -100- 600°F	SA216 Gr. WCC 650°F	SA216 Gr. WCC 700°F	SA216 Gr. WCC 750°F	SA217 Gr. WC6 800°F	SA217 Gr. WC6 850°F	SA217 Gr. WC6 900°F	SA217 Gr. WC6 950°F	SA217 Gr. WC6 1000°F	SA217 Gr. WC6 1050°F	SA217 Gr. WC9 1100°F	SA217 Gr. C12A 1100°F	SA217 Gr. C12A 1130°F	HCI-79W -C12A			HCI-79W -C12A
			HCI-76	HCI-76	HCI-76	HCI-76	HCI-78	HCI-78	HCI-78	HCI-78	HCI-78	HCI-78	HCI-78	HCI-78	HCI-79W	HCI-79W -C12A	HCI-79W -C12A		
1½ H2 4	0.994	Flange ButtWeld	1815 1795	1765 1795	1665 1795	1520 1795	1525 1795	1460 1795	1350 1795	955 1795	650 1795	430 1795	- 1795	- 1795	- 1795	- 1795	- 1795	4" Cl 300	-
2 J2 6	1.431	Flange ButtWeld	1815 1795	1765 1795	1665 1795	1520 1795	1525 1795	1460 1795	1350 1795	955 1795	650 1795	430 1795	- 1795	- 1795	- 1795	- 1795	- 1795	6" Cl 300	-
2½ K2 6	2.545	Flange ButtWeld	1815 1795	1765 1795	1665 1795	1520 1795	1525 1795	1460 1795	1350 1795	955 1795	650 1795	430 1795	- 1795	- 1795	- 1795	- 1795	- 1795	6" Cl 300	-
3 L2 6	3.341	Flange ButtWeld	1815 1795	1765 1795	1665 1795	1520 1795	1525 1795	1460 1795	1350 1795	955 1795	650 1795	430 1795	- 1795	- 1795	- 1795	- 1795	- 1795	6" Cl 300	-
3 M2 6	3.976	Flange ButtWeld	1815 1795	1765 1795	1665 1795	1520 1795	1525 1795	1460 1795	1350 1795	955 1795	650 1795	430 1795	- 1795	- 1795	- 1795	- 1795	- 1795	6" Cl 300	-
4 P2 8	7.070	Flange ButtWeld	1815 1795	1765 1795	1665 1795	1520 1795	1525 1795	1460 1795	1350 1795	955 1795	650 1795	430 1795	- 1795	- 1795	- 1795	- 1795	- 1795	8" Cl 300	-
			Class 1500 - ANSI raised face flange or welded CL 1500 inlet																
			HCI-86	HCI-86	HCI-86	HCI-86	HCI-88	HCI-88	HCI-88	HCI-88	HCI-88	HCI-88	HCI-88	HCI-89W	HCI-89W -C12A	HCI-89W -C12A			
1½ H2 4	0.994	Flange ButtWeld	3025 2865	2940 2865	2775 2865	2535 2865	2315 2865	2216 2865	2155 2865	1595 2865	1080 2865	720 2865	- 2865	- 2865	- 2865	- 2865	4" Cl 300	-	
2 J2 6	1.431	Flange ButtWeld	3025 2865	2940 2865	2775 2865	2535 2865	2540 2865	2435 2865	2245 2865	1595 2865	1080 2865	720 2865	- 2420	- 2865	- 2865	- 2865	6" Cl 300	-	
2½ K2 6	2.545	Flange ButtWeld	3025 2865	2940 2865	2775 2865	2535 2865	2540 2865	2435 2865	2245 2865	1595 2865	1080 2865	720 2865	- 2865	- 2865	- 2865	- 2865	6" Cl 300	-	
3 L2 6	3.341	Flange ButtWeld	3025 2865	2940 2865	2775 2865	2535 2865	2356 2865	2250 2865	2191 2865	1595 2865	1080 2865	720 2865	- 2833	- 2865	- 2865	- 2865	6" Cl 300	-	
3 M2 6	3.976	Flange ButtWeld	3025 2865	2450 2865	2131 2865	2022 2865	1823 2865	1748 2865	1697 2865	1595 2865	1080 2865	720 2865	- 2833	- 2865	- 2865	- 2865	6" Cl 300	-	
4 P2 8	7.070	Flange ButtWeld	3025 2865	2700 2865	2440 2865	2222 2865	2007 2865	1922 2865	1866 2865	1595 2865	1080 2865	720 2865	- 2317	- 2865	- 2650	- 2650	8" Cl 300	-	
			Class 2500 - ANSI raised face flange or welded CL 2500 inlet																
			HCI-96	HCI-96	HCI-96	HCI-96	HCI-98	HCI-98	HCI-98	HCI-98	HCI-98	HCI-98	HCI-98	HCI-99W	HCI-99W -C12A	HCI-99W -C12A			
1½ H2 4	0.994	Flange ButtWeld	3100 3100	3100 3100	3100 3100	3100 3100	2523 3100	2308 3100	2160 3100	2030 3100	1800 3100	1200 3100	- 3027	- 3100	- 2645	- 3100	4" Cl 300	-	
2 J2 6	1.431	Flange ButtWeld	3100 3100	3100 3100	3100 3100	3100 3100	3100 3100	3100 3100	3100 3100	2655 3100	1800 3100	1200 3100	- 2420	- 3100	- 3100	- 3100	6" Cl 300	-	
2½ K2 6	2.545	Flange ButtWeld	3100 3100	3100 3100	3100 3100	3100 3100	3100 3100	3100 3100	3100 3100	2655 3100	1800 3100	1200 3100	- 2978	- 3100	- 3100	- 3100	6" Cl 300	-	
3 L2 6	3.341	Flange ButtWeld	3100 3100	3100 3100	3100 3100	3100 3100	3100 3100	3100 3100	3100 3100	2655 3100	1800 3100	1200 3100	- 2833	- 3100	- 3100	- 3100	6" Cl 300	-	
3 M2 6	3.976	Flange ButtWeld	3100 3100	3100 3100	3100 3100	3100 3100	3100 3100	3100 3100	3100 3100	2655 3100	1800 3100	1200 3100	- 2833	- 3100	- 2964	- 2964	6" Cl 300	-	
4 P2 8	7.070	Flange ButtWeld	3100 3100	3100 3100	3100 3100	3100 3100	3100 3100	2963 3100	2810 3100	2655 3100	1800 3100	1200 3040	- 2317	- 3100	- 2660	- 2660	8" Cl 300	-	

* Select appropriate class to meet pressure/temperature requirements for each application.
Refer to pages 74-77 for pressure/temperature limits for standard class valves per ASME/ANSI B16.34.

CROSBY H-SERIES

STYLE HCI ISOFLEX

STYLE HCI ISOFLEX® - DIMENSIONS AND WEIGHTS

USCS (UNITED STATES CUSTOMARY SYSTEM) UNITS

Valve size inlet x orifice x outlet	HCI valve style ⁽¹⁾	General dimensions - inches													Approx. weight (lbs)			
		Inlet ID		Inlet neck OD ⁽³⁾ (welded) Bw	Center-to-face				Used to find bolt length (flanged) ⁽⁴⁾ X	Approx. height ⁽²⁾		Class 150 outlet		Class 300 outlet				
		Aw	A		Inlet	Outlet		Ew		E	Welded	Flanged	Welded	Flanged				
				Cw	C	Class 150 Dw	D	Class 300 Dw	D									
Class 300 - ANSI raised face flange or welded CL 300 inlet																		
1½ H2 3	3 ()W	1½	1½	3½	6¾	5⅞	6	6	6	6	1⅞	25½	25	105	108	110	113	
2 J2 4	3 ()W	2	2	4½	8⅞	6½	7	7	7	7	1¾	30¾	28⅞	135	132	144	141	
2½ K2 6	3 ()W	2½	2½	5¼	8⅞	8⅞	7	7	7⅞	7⅞	1⅞	34⅞	33⅞	230	230	249	249	
3 L2 6	3 ()W	3	3	6	9⅞	8¾	7½	7½	8¼	8¼	2⅞	39⅞	39	340	360	359	359	
3 M2 6	3 ()W	3	3	6	9⅞	8¾	7½	7½	8¼	8¼	2⅞	40⅞	39⅞	400	400	419	419	
4 P2 6	3 ()W	4	4	6⅞	9¾	9⅞	-	-	10	10	2⅞	45⅞	45⅞	-	-	575	617	
6 Q2 8	3 ()W	6	6	9	11½	12	-	-	11	11½	2¼	61⅞	61⅞	-	-	850	906	
6 R 8	3 ()W	6	6	9	11½	11½	-	-	11	11½	-	61⅞	61⅞	-	-	902	937	
6 RR 10	3 ()W	6	6	9	12	12	-	-	12	12	-	63	63	-	-	1179	1214	
Class 600 - ANSI raised face flange or welded CL 600 inlet																		
1½ H2 3	4 ()W	1½	1½	3½	6¾	5⅞	6	6	6	6	1⅞	25½	25	105	108	110	113	
2 J2 4	4 ()W	2	2	4½	8⅞	6½	7	7	7	7	1¾	30¾	28⅞	135	132	144	141	
2½ K2 6	4 ()W	2½	2½	5¼	8⅞	8⅞	7	7	7⅞	7⅞	1⅞	34⅞	33⅞	230	230	249	249	
3 L2 6	4 ()W	3	3	6	9⅞	8¾	7½	7½	8¼	8¼	2⅞	39⅞	39	340	360	359	359	
3 M2 6	4 ()W	3	3	6	9⅞	8¾	7½	7½	8¼	8¼	2⅞	40⅞	39⅞	400	400	419	419	
4 P2 6	4 ()W	4	4	6⅞	9¾	9⅞	-	-	10	10	2⅞	45⅞	45⅞	-	-	575	606	
6 Q2 8	4 ()W	6	6	9	11½	12	-	-	11	11½	2⅞	61⅞	61⅞	-	-	850	927	
6 R 8	4 ()W	6	6	9	11½	11⅞	-	-	11	11½	-	61⅞	61⅞	-	-	902	958	
6 R 10	4 ()W	6	6	10	12	13	-	-	11½	11½	-	62¾	63¾	-	-	1065	1126	
6 RR 10	4 ()W	6	6	9	12	12	-	-	12	12	-	63	63	-	-	1179	1234	
Class 900 - ANSI raised face flange or welded CL 900 inlet																		
1½ H2 3	5 ()W	1½	1½	3½	6¾	5⅞	6	6	6	6	1⅞	25½	25	105	114	110	119	
1½ H2 4	7 ()W	1½	1½	4½	8	7¾	-	-	6¼	6¼	2	28⅞	27⅞	-	-	140	146	
2 J2 4	5 ()W	2	2	4½	8⅞	6½	7	7	7	7	2¼	30¾	28⅞	135	146	144	155	
2 J2 6	7 ()W	2	2	5¼	11	8¼	-	-	8½	8½	2¼	36¼	33½	-	-	220	223	
2½ K2 6	5 ()W	2½	2½	5¼	8⅞	8⅞	7	7	7⅞	7⅞	2⅞	34⅞	33⅞	230	250	249	269	
2½ K2 6	7 ()W	2½	2½	7	12	9¼	-	-	8½	8½	2⅞	42⅞	39⅞	-	-	420	403	
3 L2 6	5 ()W	3	3	6	9⅞	8¾	7½	7½	8¼	8¼	2⅞	39⅞	39	340	350	359	369	
3 L2 6	7 ()W	3	3	8	12	9¾	-	-	10	10	2⅞	48¼	45¾	-	-	570	522	
3 M2 6	5 ()W	3	3	6	9⅞	8¾	7½	7½	8¼	8¼	2⅞	40⅞	39⅞	400	410	419	429	
3 M2 6	7 ()W	3	3	8	12	9¾	-	-	10	10	2⅞	48¼	45¾	-	-	570	522	
4 P2 6	5 ()W	4	4	6⅞	9¾	9⅞	-	-	10	10	2⅞	45⅞	45⅞	-	-	575	617	
4 P2 8	7 ()W	4	4	9	13¼	13¾	-	-	13	13	-	65	65½	-	-	1100	1080	
6 Q2 8	5 ()W	6	6	9	11½	12	-	-	11	11½	3	61⅞	61⅞	-	-	850	931	
6 R 8	5 ()W	6	6	9	11½	11⅞	-	-	11	11½	-	61⅞	61⅞	-	-	902	975	
6 R 10	5 ()W	6	6	10	12	13	-	-	11½	11½	-	62¾	63¾	-	-	1065	1149	
6 RR 10	5 ()W	6	6	9	12	12	-	-	12	12	-	63	63	-	-	1179	1260	

CROSBY H-SERIES

STYLE HCI ISOFLEX

STYLE HCI ISOFLEX® - DIMENSIONS AND WEIGHTS

USCS (UNITED STATES CUSTOMARY SYSTEM) UNITS

Valve size inlet x orifice x outlet	HCI valve style ⁽¹⁾	General dimensions - inches												Approx. weight (lbs)			
		Inlet ID		Inlet neck OD ⁽³⁾ (welded) Bw	Inlet		Center-to-face Outlet				Used to find bolt length (flanged) ⁽⁴⁾ X	Approx. height ⁽²⁾		Class 150 outlet		Class 300 outlet	
		Aw	A		Cw	C	Class 150		Class 300			Ew	E	Welded	Flanged	Welded	Flanged
Class 1500 - ANSI raised face flange or welded CL 1500 inlet																	
1½ H2 3	6(I)W	1½	1½	3½	6¾	5⅞	6	6	6	6	1⅝	25½	25	105	114	110	119
1½ H2 4	8(I)W	1½	1½	4½	8	7¾	-	-	6¼	6¼	2	28⅞	27⅞	-	-	140	146
2 J2 4	6(I)W	2	2	4½	8⅞	6½	7	7	7	7	2¼	30⅞	28⅞	135	146	144	155
2 J2 6	8(I)W	2	2	5¼	11	8¼	-	-	8½	8½	2¼	36¼	33½	-	-	220	223
2½ K2 6	6(I)W	2½	2½	5¼	8⅝	8⅞	7	7	7⅞	7⅞	2⅞	34⅝	33⅞	230	250	249	269
2½ K2 6	8(I)W	2½	2½	7	12	9¼	-	-	8½	8½	2⅞	42⅝	39⅞	-	-	420	403
3 L2 6	6(I)W	3	3	6	9⅞	8¾	7½	7½	8¼	8¼	2⅞	39⅝	39	340	366	359	385
3 L2 6	8(I)W	3	3	8	12	9¾	-	-	10	10	2⅞	48½	45⅞	-	-	570	534
3 M2 6	6(I)W	3	3	6	9⅞	8¾	7½	7½	8¼	8¼	2⅞	40⅞	39⅞	400	426	419	445
3 M2 6	8(I)W	3	3	8	12	9¾	-	-	10	10	2⅞	48¼	45⅞	-	-	570	534
4 P2 6	6(I)W	4	4	6⅞	9¾	9⅞	-	-	10	10	2⅝	45⅞	45⅞	-	-	575	632
4 P2 8	8(I)W	4	4	9	13¼	13¼	-	-	13	13	-	65	65½	-	-	1100	1100
6 Q2 8	6(I)W	6	6	9	11½	12	-	-	11	11½	4⅞	61⅞	61⅞	-	-	850	978
6 R 8	6(I)W	6	6	9	11½	11⅞	-	-	11	11½	-	61⅞	61⅞	-	-	902	1044
6 R 10	6(I)W	6	6	10	12	13	-	-	11½	11½	-	62¾	63¾	-	-	1065	1189
6 RR 10	6(I)W	6	6	10	12	13	-	-	12	12	-	63	64	-	-	1250	1330
Class 2500 - ANSI raised face flange or welded CL 2500 inlet																	
1½ H2 4	9(I)W	1½	1½	4½	8	7¾	-	-	6¼	6¼	2⅞	28⅞	27⅞	-	-	140	162
2 J2 6	9(I)W	2	2	5¼	11	8¼	-	-	8½	8½	2⅞	36¼	33½	-	-	220	233
2½ K2 6	9(I)W	2½	2½	7	12	9¼	-	-	8½	8½	3⅞	42⅝	39⅞	-	-	420	420
3 L2 6	9(I)W	3	3	8	12	9¾	-	-	10	10	3⅞	48¼	45⅞	-	-	570	572
3 M2 6	9(I)W	3	3	8	12	9¾	-	-	10	10	3⅞	48¼	45⅞	-	-	570	572
4 P2 8	9(I)W	4	4	9	13¼	14½	-	-	13	13	-	65	66¼	-	-	1100	1160

NOTES

1. These style designations are for standard welded inlets. For optional flanged inlet valves, the 'W' is dropped from the style designation.
 2. Dismantling height: an additional 20 inches is required.
 3. Weld prep per customer's specifications. Safety valves must be mounted on a nozzle with an inlet diameter equal to or greater than the nominal valve inlet size, dimension A. See ASME boiler and pressure code Section I and ANSI/ASME B31.1 for recommended installation.
 4. Bolt holes straddle centerline on flanged connections.
- Drain: ½" NPT for inlet sizes 1½" to 4" and ¾" NPT for 6" inlet size.

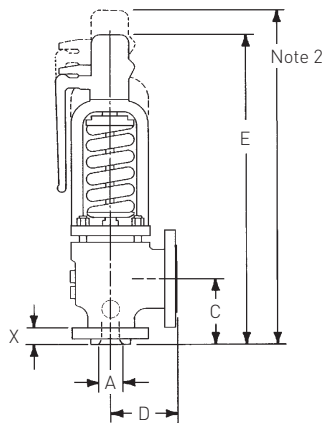
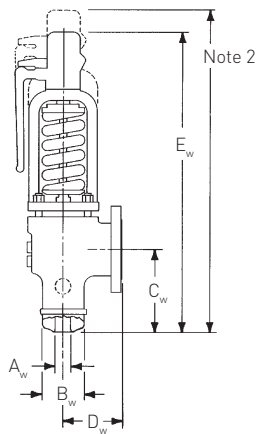

CROSBY H-SERIES

STYLE HCI ISOFLEX

STYLE HCI ISOFLEX® - PRESSURE AND TEMPERATURE LIMITS*

METRIC UNITS

Valve Size Inlet x Orifice x Outlet	Orifice Area (sq. in.)	Inlet Type	Class 300 - ANSI raised face flange or welded CL 300 inlet													Optional Flanged Outlet Class	Optional Flanged Outlet Class	
			Body Material and Temperature															
			SA216 Gr. WCC -73 to 260°C HCI-36	SA216 Gr. WCC 315°C HCI-36	SA216 Gr. WCC 343°C HCI-36	SA216 Gr. WCC 371°C HCI-36	SA216 Gr. WCC 399°C HCI-36	SA217 Gr. WC6 426°C HCI-38	SA217 Gr. WC6 454°C HCI-38	SA217 Gr. WC6 482°C HCI-38	SA217 Gr. WC6 510°C HCI-38	SA217 Gr. WC6 538°C HCI-38	SA217 Gr. WC6 566°C HCI-38	SA217 Gr. WC9 593°C -	SA217 Gr. C12A 593°C -			SA217 Gr. C12A 610°C -
1½ H2 3	0.994	Flange	45.85	41.71	40.68	38.27	34.82	35.16	33.44	31.03	22.06	14.82	10.00	-	-	-	3" Cl 150	3" Cl 300
		ButtWeld	45.85	45.85	45.85	45.85	45.85	45.85	45.85	45.85	45.85	45.85	45.85	45.85	-	-		
2 J2 4	1.431	Flange	45.85	41.71	40.68	38.27	34.82	35.16	33.44	31.03	22.06	14.82	10.00	-	-	-	4" Cl 150	4" Cl 300
		ButtWeld	45.85	45.85	45.85	45.85	45.85	45.85	45.85	45.85	45.85	45.85	45.85	45.85	-	-		
2½ K2 6	2.545	Flange	45.85	41.71	40.68	38.27	34.82	35.16	33.44	31.03	22.06	14.82	10.00	-	-	-	6" Cl 150	6" Cl 300
		ButtWeld	45.85	45.85	45.85	45.85	45.85	45.85	45.85	45.85	45.85	45.85	45.85	45.85	-	-		
3 L2 6	3.341	Flange	45.85	41.71	40.68	38.27	34.82	35.16	33.44	31.03	22.06	14.82	10.00	-	-	-	6" Cl 150	6" Cl 300
		ButtWeld	45.85	45.85	45.85	45.85	45.85	45.85	45.85	45.85	45.85	45.85	45.85	45.85	-	-		
3 M2 6	3.976	Flange	45.85	41.71	40.68	38.27	34.82	35.16	33.44	31.03	22.06	14.82	10.00	-	-	-	6" Cl 150	6" Cl 300
		ButtWeld	45.85	45.85	45.85	45.85	45.85	45.85	45.85	45.85	45.85	45.85	45.85	45.85	-	-		
4 P2 6	7.070	Flange	45.85	41.71	40.68	38.27	34.82	35.16	33.44	31.03	22.06	14.82	10.00	-	-	-	6" Cl 300	-
		ButtWeld	45.85	45.85	45.85	45.85	45.85	45.85	45.85	45.85	45.85	45.85	45.85	45.85	-	-		
6 Q2 8	12.250	Flange	45.85	41.71	40.68	38.27	34.82	35.16	33.44	31.03	22.06	14.82	10.00	-	-	-	8" Cl 300	-
		ButtWeld	45.85	45.85	45.85	45.85	45.85	45.85	45.85	45.85	45.85	45.85	45.85	45.85	-	-		
6 R 8	16.000	Flange	45.85	41.71	40.68	38.27	34.82	35.16	33.44	31.03	22.06	14.82	10.00	-	-	-	8" Cl 300	-
		ButtWeld	45.85	45.85	45.85	45.85	45.85	45.85	45.85	45.85	45.85	45.85	45.85	45.85	-	-		
6 RR 10	19.290	Flange	45.85	41.71	40.68	38.27	34.82	35.16	33.44	31.03	22.06	14.82	10.00	-	-	-	10" Cl 300	-
		ButtWeld	45.85	45.85	45.85	45.85	45.85	45.85	45.85	45.85	45.85	45.85	45.85	45.85	-	-		

Valve Size Inlet x Orifice x Outlet	Orifice Area (sq. in.)	Inlet Type	Class 600 - ANSI raised face flange or welded CL 600 inlet													Standard Flanged Outlet Class	Optional Flanged Outlet Class	
			Body Material and Temperature															
			SA216 Gr. WCC -73 to 315°C HCI-46	SA216 Gr. WCC 343°C HCI-46	SA216 Gr. WCC 371°C HCI-46	SA216 Gr. WCC 399°C HCI-46	SA217 Gr. WC6 426°C HCI-48	SA217 Gr. WC6 454°C HCI-48	SA217 Gr. WC6 482°C HCI-48	SA217 Gr. WC6 510°C HCI-48	SA217 Gr. WC6 538°C HCI-48	SA217 Gr. WC6 566°C HCI-48	SA217 Gr. WC9 593°C -	SA217 Gr. C12A 593°C -	SA217 Gr. C12A 610°C -			
1½ H2 3	0.994	Flange	83.43	81.01	76.53	69.98	69.98	67.22	62.05	44.13	29.65	19.99	-	-	-	3" Cl 150	3" Cl 300	
		ButtWeld	86.18	86.18	86.18	86.18	86.18	86.18	86.18	86.18	86.18	86.18	86.18	86.18	-			-
2 J2 4	1.431	Flange	83.43	81.01	76.53	69.98	69.98	67.22	62.05	44.13	29.65	19.99	-	-	-	4" Cl 150	4" Cl 300	
		ButtWeld	86.18	86.18	86.18	86.18	86.18	86.18	86.18	86.18	86.18	86.18	86.18	86.18	-			-
2½ K2 6	2.545	Flange	83.43	81.01	76.53	69.98	69.98	67.22	62.05	44.13	29.65	19.99	-	-	-	6" Cl 150	6" Cl 300	
		ButtWeld	86.18	86.18	86.18	86.18	86.18	86.18	86.18	86.18	86.18	86.18	86.18	86.18	-			-
3 L2 6	3.341	Flange	83.43	81.01	76.53	69.98	69.98	67.22	62.05	44.13	29.65	19.99	-	-	-	6" Cl 150	6" Cl 300	
		ButtWeld	86.18	86.18	86.18	86.18	86.18	86.18	86.18	86.18	86.18	86.18	86.18	86.18	-			-
3 M2 6	3.976	Flange	83.43	81.01	76.53	69.98	63.09	59.09	56.05	44.13	29.65	19.99	-	-	-	6" Cl 150	6" Cl 300	
		ButtWeld	86.18	86.18	86.18	86.18	86.18	86.18	86.18	86.18	86.18	86.18	86.18	86.18	-			-
4 P2 6	7.070	Flange	83.43	81.01	76.53	69.98	69.98	67.22	62.05	44.13	29.65	19.99	-	-	-	6" Cl 300	-	
		ButtWeld	86.18	86.18	86.18	86.18	86.18	86.18	86.18	86.18	86.18	86.18	86.18	86.18	-			-
6 Q2 8	12.250	Flange	83.43	81.01	76.53	69.98	69.98	67.22	62.05	44.13	29.65	19.99	-	-	-	8" Cl 300	-	
		ButtWeld	86.18	86.18	86.18	86.18	86.18	86.18	86.18	86.18	86.18	86.18	86.18	86.18	-			-
6 R 8	16.000	Flange	51.71	51.71	51.71	51.71	51.71	51.71	51.71	51.71	44.13	29.65	19.99	-	-	-	8" Cl 300	-
		ButtWeld	51.71	51.71	51.71	51.71	51.71	51.71	51.71	51.71	51.71	51.71	51.71	51.71	-	-		
6 R 10	16.000	Flange	62.05	62.05	62.05	62.05	62.05	62.05	62.05	62.05	44.13	29.65	19.99	-	-	-	10" Cl 300	-
		ButtWeld	62.05	62.05	62.05	62.05	62.05	62.05	62.05	62.05	62.05	62.05	62.05	62.05	-	-		
6 RR 10	19.290	Flange	62.05	62.05	62.05	62.05	62.05	62.05	62.05	62.05	44.13	29.65	19.99	-	-	-	10" Cl 300	-
		ButtWeld	62.05	62.05	62.05	62.05	62.05	62.05	62.05	62.05	62.05	62.05	62.05	62.05	-	-		

* Select appropriate class to meet pressure/temperature requirements for each application.
 Refer to pages 74-77 for pressure/temperature limits for standard class valves per ASME/ANSI B16.34.

CROSBY H-SERIES

STYLE HCI ISOFLEX

STYLE HCI ISOFLEX® - PRESSURE AND TEMPERATURE LIMITS*

METRIC UNITS

Valve Size Inlet x Orifice x Outlet	Orifice Area (sq. in.)	Inlet Type	Class 900 - ANSI raised face flange or welded CL 900 inlet													Standard Flanged Outlet Class	Optional Flanged Outlet Class		
			Body Material and Temperature																
			SA216 Gr. WCC -73- 315°C	SA216 Gr. WCC 343°C	SA216 Gr. WCC 371°C	SA216 Gr. WCC 399°C	SA217 Gr. WC6 426°C	SA217 Gr. WC6 454°C	SA217 Gr. WC6 482°C	SA217 Gr. WC6 510°C	SA217 Gr. WC6 538°C	SA217 Gr. WC6 566°C	SA217 Gr. WC9 593°C	SA217 Gr. C12A 593°C	SA217 Gr. C12A 610°C				
1½ H2 3	0.994	Flange ButtWeld	103.42 103.42	103.42 103.42	103.42 103.42	103.42 103.42	103.42 103.42	103.42 103.42	100.66 103.42	93.08 103.42	65.84 103.42	44.82 103.42	29.65 103.42	- 103.42	- 103.42	3" Cl 150	3" Cl 300		
2 J2 4	1.431	Flange ButtWeld	103.42 103.42	103.42 103.42	103.42 103.42	103.42 103.42	103.42 103.42	100.66 103.42	93.08 103.42	65.84 103.42	44.82 103.42	29.65 103.42	- 103.42	- 103.42	4" Cl 150	4" Cl 300			
2½ K2 6	2.545	Flange ButtWeld	103.42 103.42	103.42 103.42	103.42 103.42	103.42 103.42	103.42 103.42	100.66 103.42	93.08 103.42	65.84 103.42	44.82 103.42	29.65 103.42	- 103.42	- 103.42	6" Cl 150	6" Cl 300			
3 L2 6	3.341	Flange ButtWeld	103.42 103.42	103.42 103.42	103.42 103.42	103.42 103.42	103.42 103.42	100.66 103.42	93.08 103.42	65.84 103.42	44.82 103.42	29.65 103.42	- 103.42	- 103.42	6" Cl 150	6" Cl 300			
3 M2 6	3.976	Flange ButtWeld	103.42 103.42	103.42 103.42	103.42 103.42	103.42 103.42	103.42 103.42	100.66 103.42	93.08 103.42	65.84 103.42	44.82 103.42	29.65 103.42	- 103.28	- 103.42	6" Cl 150	6" Cl 300			
4 P2 6	7.070	Flange ButtWeld	103.42 103.42	103.42 103.42	103.42 103.42	103.42 103.42	103.42 103.42	100.66 103.42	93.08 103.42	65.84 103.42	44.82 103.42	29.65 87.98	- 65.43	- 88.25	6" Cl 300	-			
6 Q2 8	12.250	Flange ButtWeld	103.42 103.42	103.42 103.42	103.42 103.42	103.42 103.42	103.42 103.42	100.66 103.42	93.08 103.42	65.84 103.42	44.82 103.42	29.65 103.42	- 95.35	- 103.42	8" Cl 300	-			
6 R 8	16.000	Flange ButtWeld	62.05 62.05	62.05 62.05	62.05 62.05	62.05 62.05	62.05 62.05	62.05 62.05	62.05 62.05	62.05 62.05	44.82 62.05	29.65 62.05	- 62.05	- 62.05	8" Cl 300	-			
6 R 10	16.000	Flange ButtWeld	82.74 82.74	82.74 82.74	82.74 82.74	82.74 82.74	82.74 82.74	82.74 82.74	82.74 82.74	65.84 82.74	44.82 82.74	29.65 82.74	- 82.74	- 82.74	10" Cl 300	-			
6 RR 10	19.290	Flange ButtWeld	62.05 62.05	62.05 62.05	62.05 62.05	62.05 62.05	62.05 62.05	62.05 62.05	62.05 62.05	62.05 62.05	44.82 62.05	29.65 62.05	- 50.75	- 62.05	10" Cl 300	-			
			Class 1500 - ANSI raised face flange or welded CL 1500 inlet																
			HCI-66	HCI-66	HCI-66	HCI-66	HCI-68	HCI-68	HCI-68	HCI-68	HCI-68	HCI-68	HCI-68	HCI-68	HCI-68	HCI-69W -C12A	HCI-69W -C12A		
1½ H2 3	0.994	Flange ButtWeld	103.42 103.42	103.42 103.42	103.42 103.42	103.42 103.42	103.42 103.42	103.42 103.42	103.42 103.42	103.42 103.42	103.42 103.42	74.46 103.42	49.64 103.42	- 103.42	- 103.42	- 103.42	3" Cl 150	3" Cl 300	
2 J2 4	1.431	Flange ButtWeld	103.42 103.42	103.42 103.42	103.42 103.42	103.42 103.42	103.42 103.42	103.42 103.42	103.42 103.42	103.42 103.42	103.42 103.42	74.46 103.42	49.64 103.42	- 103.42	- 103.42	- 103.42	4" Cl 150	4" Cl 300	
2½ K2 6	2.545	Flange ButtWeld	103.42 103.42	103.42 103.42	103.42 103.42	103.42 103.42	103.42 103.42	103.42 103.42	103.42 103.42	103.42 103.42	103.42 103.42	74.46 103.42	49.64 103.42	- 103.42	- 103.42	- 103.42	6" Cl 150	6" Cl 300	
3 L2 6	3.341	Flange ButtWeld	103.42 103.42	103.42 103.42	103.42 103.42	103.42 103.42	103.42 103.42	103.42 103.42	103.42 103.42	103.42 103.42	103.42 103.42	74.46 103.42	49.64 103.42	- 103.42	- 103.42	- 103.42	6" Cl 150	6" Cl 300	
3 M2 6	3.976	Flange ButtWeld	103.42 103.42	103.42 103.42	103.42 103.42	103.42 103.42	103.42 103.42	103.42 103.42	103.42 103.42	103.42 103.42	103.42 103.42	74.46 103.42	49.64 103.42	- 103.28	- 103.42	- 103.42	6" Cl 150	6" Cl 300	
4 P2 6	7.070	Flange ButtWeld	103.42 103.42	103.42 103.42	103.42 103.42	103.42 103.42	103.42 103.42	103.42 103.42	103.42 103.42	103.42 103.42	103.42 103.42	74.46 101.49	49.64 74.95	- 108.80	- 89.84	- 89.84	6" Cl 300	-	
6 Q2 8	12.250	Flange ButtWeld	103.42 103.42	103.42 103.42	103.42 103.42	103.42 103.42	103.42 103.42	103.42 103.42	103.42 103.42	103.42 103.42	103.42 103.42	74.46 103.42	49.64 103.42	- 95.84	- 103.42	- 103.42	8" Cl 300	-	
6 R 8	16.000	Flange ButtWeld	103.42 103.42	103.42 103.42	103.42 103.42	103.42 103.42	103.42 103.42	103.42 103.42	103.42 103.42	103.42 103.42	103.42 103.42	74.46 84.53	49.64 70.19	- 97.15	- 84.19	- 84.19	8" Cl 300	-	
6 R 10	16.000	Flange ButtWeld	103.42 103.42	103.42 103.42	103.42 103.42	103.42 103.42	103.42 103.42	103.42 103.42	103.42 103.42	103.42 103.42	103.42 103.42	74.46 91.70	49.64 128.52	- 110.25	- 110.25	- 110.25	10" Cl 300	-	
6 RR 10	19.290	Flange ButtWeld	103.42 103.42	103.42 103.42	103.42 103.42	103.42 103.42	103.42 103.42	103.42 103.42	103.42 103.42	103.42 103.42	103.42 103.42	74.46 80.94	49.64 103.42	- 103.42	- 96.94	- 96.94	10" Cl 300	-	

* Select appropriate class to meet pressure/temperature requirements for each application.
Refer to pages 74-77 for pressure/temperature limits for standard class valves per ASME/ANSI B16.34.

CROSBY H-SERIES

STYLE HCI ISOFLEX

STYLE HCI ISOFLEX® - PRESSURE AND TEMPERATURE LIMITS*

METRIC UNITS

Valve Size Inlet x Orifice x Outlet	Orifice Area (sq. in.)	Inlet Type	Class 900 - ANSI raised face flange or welded CL 900 inlet														Standard Flanged Outlet Class	Optional Flanged Outlet Class													
			Body Material and Temperature																												
			SA216 Gr. WCC -73 to 315°C	SA216 Gr. WCC 343°C	SA216 Gr. WCC 371°C	SA216 Gr. WCC 399°C	SA217 Gr. WC6 426°C	SA217 Gr. WC6 454°C	SA217 Gr. WC6 482°C	SA217 Gr. WC6 510°C	SA217 Gr. WC6 538°C	SA217 Gr. WC6 566°C	SA217 Gr. WC9 593°C	SA217 Gr. C12A 593°C	SA217 Gr. C12A 610°C	HCI-76			HCI-76	HCI-76	HCI-76	HCI-78	HCI-78	HCI-78	HCI-78	HCI-78	HCI-78	HCI-78	HCI-79W	HCI-79W -C12A	HCI-79W -C12A
1½ H2 4	0.994	Flange ButtWeld	125.14 123.76	121.69 123.76	114.80 123.76	104.80 123.76	105.15 123.76	100.66 123.76	93.08 123.76	65.84 123.76	44.82 123.76	29.65 123.76	-	-	-	-	-	-	-	-	-	-	-	-	-	-	-	-	4" Cl 300	-	
2 J2 6	1.431	Flange ButtWeld	125.14 123.76	121.69 123.76	114.80 123.76	104.80 123.76	105.15 123.76	100.66 123.76	93.08 123.76	65.84 123.76	44.82 123.76	29.65 123.76	-	-	-	-	-	-	-	-	-	-	-	-	-	-	-	-	6" Cl 300	-	
2½ K2 6	2.545	Flange ButtWeld	125.14 123.76	121.69 123.76	114.80 123.76	104.80 123.76	105.15 123.76	100.66 123.76	93.08 123.76	65.84 123.76	44.82 123.76	29.65 123.76	-	-	-	-	-	-	-	-	-	-	-	-	-	-	-	-	6" Cl 300	-	
3 L2 6	3.341	Flange ButtWeld	125.14 123.76	121.69 123.76	114.80 123.76	104.80 123.76	105.15 123.76	100.66 123.76	93.08 123.76	65.84 123.76	44.82 123.76	29.65 123.76	-	-	-	-	-	-	-	-	-	-	-	-	-	-	-	-	6" Cl 300	-	
3 M2 6	3.976	Flange ButtWeld	125.14 123.76	121.69 123.76	114.80 123.76	104.80 123.76	105.15 123.76	100.66 123.76	93.08 123.76	65.84 123.76	44.82 123.76	29.65 123.76	-	-	-	-	-	-	-	-	-	-	-	-	-	-	-	-	6" Cl 300	-	
4 P2 8	7.070	Flange ButtWeld	125.14 123.76	121.69 123.76	114.80 123.76	104.80 123.76	105.15 123.76	100.66 123.76	93.08 123.76	65.84 123.76	44.82 123.76	29.65 123.76	-	-	-	-	-	-	-	-	-	-	-	-	-	-	-	-	8" Cl 300	-	
			Class 1500 - ANSI raised face flange or welded CL 1500 inlet																												
			HCI-86	HCI-86	HCI-86	HCI-86	HCI-88	HCI-88	HCI-88	HCI-88	HCI-88	HCI-88	HCI-88	HCI-88	HCI-88	HCI-88	HCI-88	HCI-88	HCI-88	HCI-88	HCI-88	HCI-88	HCI-88	HCI-88	HCI-88	HCI-88	HCI-88	HCI-88	HCI-88	HCI-88	HCI-88
1½ H2 4	0.994	Flange ButtWeld	208.57 197.53	202.71 197.53	191.33 197.53	174.78 197.53	159.61 197.53	152.79 197.53	148.58 197.53	109.97 197.53	74.46 197.53	49.64 197.53	-	-	-	-	-	-	-	-	-	-	-	-	-	-	-	-	-	4" Cl 300	-
2 J2 6	1.431	Flange ButtWeld	208.57 197.53	202.71 197.53	191.33 197.53	174.78 197.53	175.13 197.53	167.89 197.53	154.79 197.53	109.97 197.53	74.46 197.53	49.64 197.53	-	-	-	-	-	-	-	-	-	-	-	-	-	-	-	-	-	6" Cl 300	-
2½ K2 6	2.545	Flange ButtWeld	208.57 197.53	202.71 197.53	191.33 197.53	174.78 197.53	175.13 197.53	167.89 197.53	154.79 197.53	109.97 197.53	74.46 197.53	49.64 197.53	-	-	-	-	-	-	-	-	-	-	-	-	-	-	-	-	-	6" Cl 300	-
3 L2 6	3.341	Flange ButtWeld	208.57 197.53	202.71 197.53	191.33 197.53	174.78 197.53	162.44 197.53	155.13 197.53	151.06 197.53	109.97 197.53	74.46 197.53	49.64 197.53	-	-	-	-	-	-	-	-	-	-	-	-	-	-	-	-	6" Cl 300	-	
3 M2 6	3.976	Flange ButtWeld	208.57 197.53	168.92 197.53	146.93 197.53	139.41 197.53	125.69 197.53	120.52 197.53	117.00 197.53	109.97 197.53	74.46 197.53	49.64 197.53	-	-	-	-	-	-	-	-	-	-	-	-	-	-	-	-	6" Cl 300	-	
4 P2 8	7.070	Flange ButtWeld	208.57 197.53	186.16 197.53	168.23 197.53	153.20 197.53	138.38 197.53	132.52 197.53	128.66 197.53	109.97 197.53	74.46 197.53	49.64 197.53	-	-	-	-	-	-	-	-	-	-	-	-	-	-	-	-	8" Cl 300	-	
			Class 2500 - ANSI raised face flange or welded CL 2500 inlet																												
			HCI-96	HCI-96	HCI-96	HCI-96	HCI-98	HCI-98	HCI-98	HCI-98	HCI-98	HCI-98	HCI-98	HCI-98	HCI-98	HCI-98	HCI-98	HCI-98	HCI-98	HCI-98	HCI-98	HCI-98	HCI-98	HCI-98	HCI-98	HCI-98	HCI-98	HCI-98	HCI-98	HCI-98	HCI-98
1½ H2 4	0.994	Flange ButtWeld	213.74 213.74	213.74 213.74	213.74 213.74	213.74 213.74	173.95 213.74	159.13 213.74	148.93 213.74	139.96 213.74	124.11 213.74	82.74 213.74	-	-	-	-	-	-	-	-	-	-	-	-	-	-	-	-	-	4" Cl 300	-
2 J2 6	1.431	Flange ButtWeld	213.74 213.74	213.74 213.74	213.74 213.74	213.74 213.74	213.74 213.74	213.74 213.74	213.74 213.74	183.06 213.74	124.11 213.74	82.74 213.74	-	-	-	-	-	-	-	-	-	-	-	-	-	-	-	-	6" Cl 300	-	
2½ K2 6	2.545	Flange ButtWeld	213.74 213.74	213.74 213.74	213.74 213.74	213.74 213.74	213.74 213.74	213.74 213.74	213.74 213.74	183.06 213.74	124.11 213.74	82.74 213.74	-	-	-	-	-	-	-	-	-	-	-	-	-	-	-	-	6" Cl 300	-	
3 L2 6	3.341	Flange ButtWeld	213.74 213.74	213.74 213.74	213.74 213.74	213.74 213.74	213.74 213.74	213.74 213.74	213.74 213.74	183.06 213.74	124.11 213.74	82.74 213.74	-	-	-	-	-	-	-	-	-	-	-	-	-	-	-	-	6" Cl 300	-	
3 M2 6	3.976	Flange ButtWeld	213.74 213.74	213.74 213.74	213.74 213.74	213.74 213.74	213.74 213.74	213.74 213.74	213.74 213.74	183.06 213.74	124.11 213.74	82.74 213.74	-	-	-	-	-	-	-	-	-	-	-	-	-	-	-	-	6" Cl 300	-	
4 P2 8	7.070	Flange ButtWeld	213.74 213.74	213.74 213.74	213.74 213.74	213.74 213.74	213.74 213.74	204.29 213.74	193.74 213.74	183.06 213.74	124.11 213.74	82.74 213.74	-	-	-	-	-	-	-	-	-	-	-	-	-	-	-	-	8" Cl 300	-	

* Select appropriate class to meet pressure/temperature requirements for each application.
Refer to pages 74-77 for pressure/temperature limits for standard class valves per ASME/ANSI B16.34.

CROSBY H-SERIES

STYLE HCI ISOFLEX

STYLE HCI ISOFLEX® - DIMENSIONS AND WEIGHTS

METRIC UNITS

Valve size inlet x orifice x outlet	HCI valve style ⁽¹⁾	General dimensions - millimeters												Approx. weight (kg)			
		Inlet ID		Inlet neck OD ⁽³⁾ (welded) Bw	Inlet		Center-to-face Outlet				Used to find bolt length (flanged) ⁽⁴⁾ X	Approx. height ⁽²⁾		Class 150 outlet		Class 300 outlet	
		Aw	A		Cw	C	Dw	D	Dw	D		Ew	E	Welded	Flanged	Welded	Flanged
Class 300 - ANSI raised face flange or welded CL 300 inlet																	
1½ H2 3	3(J)W	38.1	38.1	88.9	161.9	149.2	152.4	152.4	152.4	152.4	39.7	647.7	635.0	48	49	50	51
2 J2 4	3(J)W	50.8	50.8	114.3	214.3	165.1	177.8	177.8	177.8	177.8	44.5	771.5	722.3	61	60	65	64
2½ K2 6	3(J)W	63.5	63.5	133.4	227.0	204.8	177.8	177.8	200.0	200.0	49.2	871.5	849.3	104	104	113	113
3 L2 6	3(J)W	76.2	76.2	152.4	246.1	222.3	190.5	190.5	209.6	209.6	52.4	1014.4	990.6	154	163	163	163
3 M2 6	3(J)W	76.2	76.2	152.4	246.1	222.3	190.5	190.5	209.6	209.6	52.4	1017.6	993.8	181	181	190	190
4 P2 6	3(J)W	101.6	101.6	174.6	238.1	231.8	-	-	254.0	254.0	52.4	1163.6	1157.3	-	-	261	280
6 Q2 8	3(J)W	152.4	152.4	228.6	292.1	304.8	-	-	279.4	292.1	57.2	1552.6	1565.3	-	-	386	411
6 R 8	3(J)W	152.4	152.4	228.6	292.1	292.1	-	-	279.4	292.1	-	1560.5	1560.5	-	-	409	425
6 RR 10	3(J)W	152.4	152.4	228.6	304.8	304.8	-	-	304.8	304.8	-	1600.2	1600.2	-	-	535	551
Class 600 - ANSI raised face flange or welded CL 600 inlet																	
1½ H2 3	4(J)W	38.1	38.1	88.9	161.9	149.2	152.4	152.4	152.4	152.4	39.7	647.7	635.0	48	49	50	51
2 J2 4	4(J)W	50.8	50.8	114.3	214.3	165.1	177.8	177.8	177.8	177.8	44.5	771.5	722.3	61	60	65	64
2½ K2 6	4(J)W	63.5	63.5	133.4	227.0	204.8	177.8	177.8	200.0	200.0	49.2	871.5	849.3	104	104	113	113
3 L2 6	4(J)W	76.2	76.2	152.4	246.1	222.3	190.5	190.5	209.6	209.6	52.4	1014.4	990.6	154	163	163	163
3 M2 6	4(J)W	76.2	76.2	152.4	246.1	222.3	190.5	190.5	209.6	209.6	52.4	1017.6	993.8	181	181	190	190
4 P2 6	4(J)W	101.6	101.6	174.6	238.1	231.8	-	-	254.0	254.0	58.7	1163.6	1157.3	-	-	261	275
6 Q2 8	4(J)W	152.4	152.4	228.6	292.1	304.8	-	-	279.4	292.1	68.3	1552.6	1565.3	-	-	386	421
6 R 8	4(J)W	152.4	152.4	228.6	292.1	293.7	-	-	279.4	292.1	-	1560.5	1562.1	-	-	409	435
6 R 10	4(J)W	152.4	152.4	254.0	304.8	330.2	-	-	292.1	292.1	-	1593.9	1619.3	-	-	483	511
6 RR 10	4(J)W	152.4	152.4	228.6	304.8	304.8	-	-	304.8	304.8	-	1600.2	1600.2	-	-	535	560
Class 900 - ANSI raised face flange or welded CL 900 inlet																	
1½ H2 3	5(J)W	38.1	38.1	88.9	161.9	149.2	152.4	152.4	152.4	152.4	49.2	647.7	635.0	48	52	50	54
1½ H2 4	7(J)W	38.1	38.1	114.3	203.2	196.9	-	-	158.8	158.8	50.8	714.4	708.0	-	-	64	66
2 J2 4	5(J)W	50.8	50.8	114.3	214.3	165.1	177.8	177.8	177.8	177.8	57.2	771.5	722.3	61	66	65	70
2 J2 6	7(J)W	50.8	50.8	133.4	279.4	209.6	-	-	215.9	215.9	57.2	920.8	850.9	-	-	100	101
2½ K2 6	5(J)W	63.5	63.5	133.4	227.0	204.8	177.8	177.8	200.0	200.0	61.9	871.5	849.3	104	113	113	122
2½ K2 6	7(J)W	63.5	63.5	177.8	304.8	204.8	-	-	215.9	215.9	65.1	1074.7	1004.9	-	-	191	183
3 L2 6	5(J)W	76.2	76.2	152.4	246.1	222.3	190.5	190.5	209.6	209.6	58.7	1014.4	990.6	154	159	163	167
3 L2 6	7(J)W	76.2	76.2	203.2	304.8	238.1	-	-	254.0	254.0	58.7	1231.9	1158.9	-	-	259	237
3 M2 6	5(J)W	76.2	76.2	152.4	246.1	222.3	190.5	190.5	209.6	209.6	74.6	1017.6	993.8	181	186	190	195
3 M2 6	7(J)W	76.2	76.2	203.2	304.8	238.1	-	-	254.0	254.0	58.7	1231.9	1158.9	-	-	259	237
4 P2 6	5(J)W	101.6	101.6	174.6	238.1	231.8	-	-	254.0	254.0	65.1	1163.6	1157.3	-	-	261	280
4 P2 8	7(J)W	101.6	101.6	228.6	336.6	349.3	-	-	330.2	330.2	-	1651.0	1663.7	-	-	499	490
6 Q2 8	5(J)W	152.4	152.4	228.6	292.1	304.8	-	-	279.4	292.1	76.2	-	1565.3	-	-	386	422
6 R 8	5(J)W	152.4	152.4	228.6	292.1	293.7	-	-	279.4	292.1	-	1560.5	1562.1	-	-	409	442
6 R 10	5(J)W	152.4	152.4	254.0	304.8	330.2	-	-	292.1	292.1	-	1593.9	1619.3	-	-	483	521
6 RR 10	5(J)W	152.4	152.4	228.6	304.8	304.8	-	-	304.8	304.8	-	1600.2	1600.2	-	-	535	572

CROSBY H-SERIES

STYLE HCI ISOFLEX

STYLE HCI ISOFLEX® - DIMENSIONS AND WEIGHTS

METRIC UNITS

Valve size inlet x orifice x outlet	HCI valve style ^[1]	General dimensions - mm												Approx. weight (kg)			
		Inlet ID		Inlet neck OD ^[3] (welded) Bw	Center-to-face				Used to find bolt length (flanged) ^[4] X	Approx. height ^[2]		Class 150 outlet		Class 300 outlet			
		Aw	A		Inlet Cw	C	Outlet			Ew	E	Welded	Flanged	Welded	Flanged		
Class 1500 - ANSI raised face flange or welded CL 1500 inlet																	
1½ H2 3	6(J)W	38.1	38.1	88.9	161.9	149.2	152.4	152.4	152.4	152.4	49.2	647.7	635.0	48	52	50	54
1½ H2 4	8(J)W	38.1	38.1	114.3	203.2	196.9	-	-	158.8	158.8	50.8	714.4	708.0	-	-	64	66
2 J2 4	6(J)W	50.8	50.8	114.3	214.3	165.1	177.8	177.8	177.8	177.8	57.2	771.5	722.3	61	66	65	70
2 J2 6	8(J)W	50.8	50.8	133.4	279.4	209.6	-	-	215.9	215.9	57.2	920.8	850.9	-	-	100	101
2½ K2 6	6(J)W	63.5	63.5	133.4	227.0	204.8	177.8	177.8	200.0	200.0	61.9	871.5	849.3	104	113	113	122
2½ K2 6	8(J)W	63.5	63.5	177.8	304.8	204.8	-	-	215.9	215.9	65.1	1074.7	1004.9	-	-	191	183
3 L2 6	6(J)W	76.2	76.2	152.4	246.1	222.3	190.5	190.5	209.6	209.6	68.3	1014.4	990.6	154	166	163	175
3 L2 6	8(J)W	76.2	76.2	203.2	304.8	238.1	-	-	254.0	254.0	68.3	1231.9	1158.9	-	-	259	242
3 M2 6	6(J)W	76.2	76.2	152.4	246.1	222.3	190.5	190.5	209.6	209.6	68.3	1017.6	993.8	181	193	190	202
3 M2 6	8(J)W	76.2	76.2	203.2	304.8	238.1	-	-	254.0	254.0	68.3	1225.6	1158.9	-	-	259	242
4 P2 6	6(J)W	101.6	101.6	174.6	238.1	231.8	-	-	254.0	254.0	74.6	1163.6	1157.3	-	-	261	287
4 P2 8	8(J)W	101.6	101.6	228.6	336.6	349.3	-	-	330.2	330.2	-	1651.0	1663.7	-	-	499	499
6 Q2 8	6(J)W	152.4	152.4	228.6	292.1	304.8	-	-	279.4	292.1	103.2	1552.6	1565.3	-	-	386	444
6 R 8	6(J)W	152.4	152.4	228.6	292.1	293.7	-	-	279.4	292.1	-	1560.5	1562.1	-	-	409	474
6 R 10	6(J)W	152.4	152.4	254.0	304.8	330.2	-	-	292.1	292.1	-	1593.9	1619.3	-	-	483	539
6 RR 10	6(J)W	152.4	152.4	254.0	304.8	330.2	-	-	304.8	304.8	-	1600.2	1625.6	-	-	568	605
Class 2500 - ANSI raised face flange or welded CL 2500 inlet																	
1½ H2 4	9(J)W	38.1	38.1	114.3	203.2	196.9	-	-	158.8	158.8	71.4	714.4	708.0	-	-	64	74
2 J2 6	9(J)W	50.8	50.8	133.4	279.4	209.6	-	-	215.9	215.9	71.4	920.8	850.9	-	-	100	101
2½ K2 6	9(J)W	63.5	63.5	177.8	304.8	235.0	-	-	215.9	215.9	77.8	1074.7	1004.9	-	-	191	191
3 L2 6	9(J)W	76.2	76.2	203.2	304.8	238.1	-	-	254.0	254.0	87.3	1231.9	1158.9	-	-	259	260
3 M2 6	9(J)W	76.2	76.2	203.2	304.8	238.1	-	-	254.0	254.0	87.3	1231.9	1158.9	-	-	259	260
4 P2 8	9(J)W	101.6	101.6	228.6	336.6	368.3	-	-	330.2	330.2	-	1651.0	1682.8	-	-	499	526

NOTES

- These style designations are for standard welded inlets. For optional flanged inlet valves, the 'W' is dropped from the style designation.
 - Dismantling height: an additional 508 mm is required.
 - Weld prep per customer's specifications. Safety valves must be mounted on a nozzle with an inlet diameter equal to or greater than the nominal valve inlet size, dimension A. See ASME boiler and pressure code Section I and ANSI/ASME B31.1 for recommended installation.
 - Bolt holes straddle centerline on flanged connections.
- Drain: ½" NPT for inlet sizes 1½" to 4" and ¾" NPT for 6" inlet size.

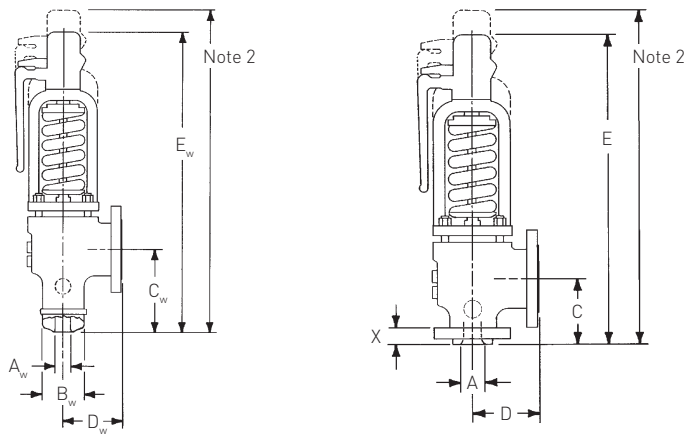

CROSBY H-SERIES

STYLE HSJ DIRECT SPRING SAFETY VALVE

STYLE HSJ

Style HSJ is a full nozzle reaction type safety valve designed for saturated and superheated steam service on drums, superheater outlets, reheater inlets and outlets and economizer applications.

FEATURES

- Increases Operating Efficiency
 - FLEXI-DISC seat design is recessed for pressure and temperature equalization, ensuring a flat and tight seal.
 - FLEXI-DISC seat tightness up to 93%. For seat tightness greater than 93% consult factory.
 - Meets the requirements of ASME Code Section I, Power Boilers and Section VIII for steam service.
 - May also be used for ASME VIII off boiler steam applications for higher operating pressures.
- Reduces Maintenance Costs
 - Replaceable full nozzle design requiring no special tools facilitates ease of maintenance and longer service life.
 - Single bonnet design allows set pressure changes simply by changing-out the spring.
- Minimizes Installation Costs
 - High discharge coefficient results in the most economical valve selection.

TECHNICAL DATA

Sizes:	1½" x 2" to 6" x 8" (DN 40 x DN 50 to DN 150 x DN 200)
Orifices:	0.307 to 11.045 in ² (1.98 to 71.25 cm ²)
Inlet ratings:	ANSI Class 150 to 2500
Maximum temperature:	1000°F (538°)
Maximum set pressure:	2700 psig (186.2 barg)
Codes:	ASME I and VIII
Bonnet:	Open or closed (heat transfer fluid)

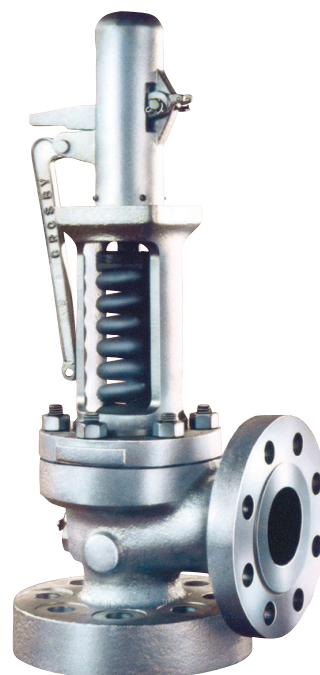

CROSBY H-SERIES

STYLE HSJ

PRODUCT OVERVIEW

Style HSJ safety valves are recommended for use on boilers at design pressure from 15-600 psig (1-41 barg). For economizer, Dowtherm® and Section VIII applications, the valves are designed for pressures to 2700 psig (186 barg) and temperatures to 1000°F (538°C).

HSJ valves are available in sizes 1½" F 2" to 6" Q 8" with ANSI Class 150, 300, 600, 900, 1500 and 2500 inlet flanges.

HIGH PERFORMANCE

The adjustable nozzle ring (3) and guide ring (9) utilize the reactive and expansive forces of flowing steam to provide full lift. Valve capacity is governed by the nozzle throat area alone. With high capacity valves, positive overpressure protection is achieved with the fewest valves.

TWO RING DESIGN

Precise blowdown control is provided by the adjustable two-ring design. Blowdown is adjustable while the valve is installed in the system.

SHUT TIGHT - STAY TIGHT

The FLEXI-DISC® (6) is recessed for pressure and temperature equalization ensuring a flat, tight seal capable of containing system pressure at 93% of the valve's set pressure.

PRECISE POPPING POINT

Centering of the disc (6) through the low friction guide (8) ensures that the valves open precisely at set pressure, even after repeated cycling.

OPTIONS

Closed and open bonnets are available for each valve size up to the maximum pressure rating. Closed bonnet valves, equipped with bonnet vents, are recommended for ASME Section VIII outdoor service. For ASME code Section I, outdoor applications, select an open bonnet with weatherhood. Specify open or closed bonnet when ordering.

Note: bonnet vents are essential for proper valve operation and should not be plugged (except for Style HSJ-DOW).

STYLE HSJ-DOW FOR DOWTHERM® SERVICE

Style HSJ-DOW has been designed to cope with the severe demands placed on a Dowtherm® vaporizer safety relief valve, where temperatures are high and absolute seat tightness is required. This valve is furnished with an unvented closed bonnet, a type A screwed cap and has an alloy steel spring for high operating temperatures.

Style HSJ-DOW meets the requirements of the ASME boiler and pressure vessel code, Section I, part PVG, 'Requirements for organic fluid vaporizer generators'. For organic fluid capacities, consult your sales representative.

STYLE HSJ

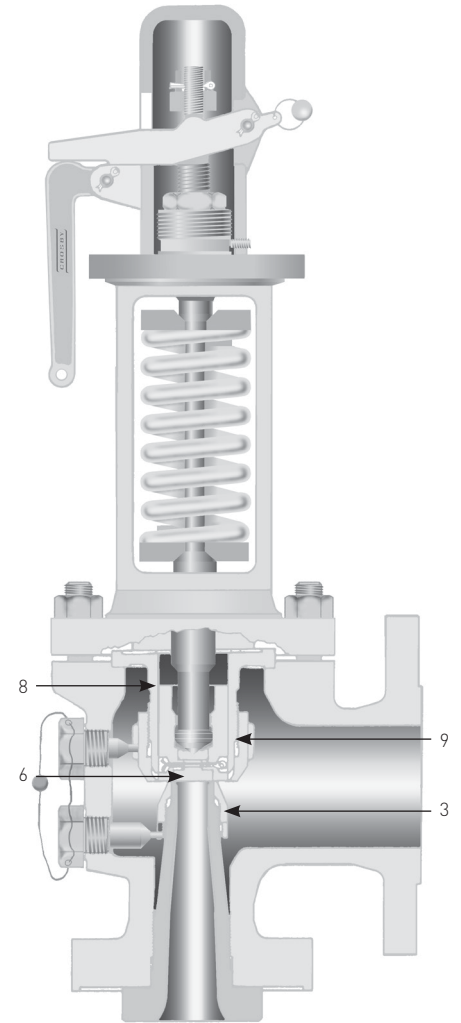

STYLE HSJ-DOW

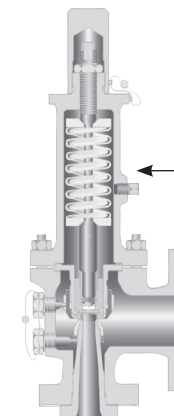

NOTE
Bonnet vent plugged only in HSJ-DOW

CROSBY H-SERIES

STYLE HSJ

MATERIALS

Part ref.		Material and maximum temperature		Spare parts designation ^(1,2,3)
No.	Part name	750°F (399°C)	1000°F (538°C)	
1	Body	Carbon steel	Alloy steel	
2	Nozzle	SA-216 Gr. WCB	SA-217 Gr. WC6	3
3	Nozzle ring	Stainless steel	Stainless steel	3
4	Nozzle ring set screw	Stainless steel	Stainless steel	
5*	Disc holder	Nickel alloy	Nickel alloy	2
6*	Disc insert	Stainless	Steel stainless steel	1
6A*	Disc	Stainless steel	Stainless steel	1
7*	Disc insert cotter	Stainless steel	Stainless steel	1
8	Guide	Nickel alloy	Nickel alloy	2
9	Guide ring	Stainless steel	Stainless steel	3
10	Guide ring set screw	Stainless steel	Stainless steel	
11	Spindle assembly	Stainless steel	Stainless steel	2
12	Spring	Alloy steel	Alloy steel	
		Corrosion resistant coating	Corrosion resistant coating	
13	Spring washers	Steel	Steel	
14	Bonnet	Carbon steel	Alloy steel	
		SA-216 Gr. WCB	SA-217 Gr. WC6	
15	Bonnet stud	SA-193 Gr. B7	SA-193 Gr. B7	
16	Bonnet stud nut	SA-194 Gr. 2H	SA-194 Gr. 2H	
17	Adjusting bolt	Stainless steel	Stainless steel	
18	Adjusting bolt nut	Steel	Steel	
19	Cap/lever assembly	Steel/iron	Steel/iron	

* One piece disc (6A) replaces part reference numbers 5, 6 and 7 in orifice sizes F, G, H and J (Class 150, 300, 600 only)

NOTES

1. Consumable spare parts: valve parts which should be replaced as part of any disassembly, and discs and/or disc inserts which must be replaced if seats are damaged.
2. Repair spare parts: valve parts exposed to wear and/or corrosion during normal operation. They are in the fluid flow path and may require replacement as part of any repair.
3. Insurance spare parts: valve parts exposed to process or environmental wear and/or corrosion and may require replacement as part of a major repair.

Emerson recommends that sufficient inventory of spare parts be maintained to support process requirements. Always be sure to use genuine Crosby parts to ensure continued product performance and warranty.

For information on installation and care, instruction No. IS-V3146, 'Installation, maintenance and adjustment instruction for Crosby Style HSJ safety valves' is available on request.

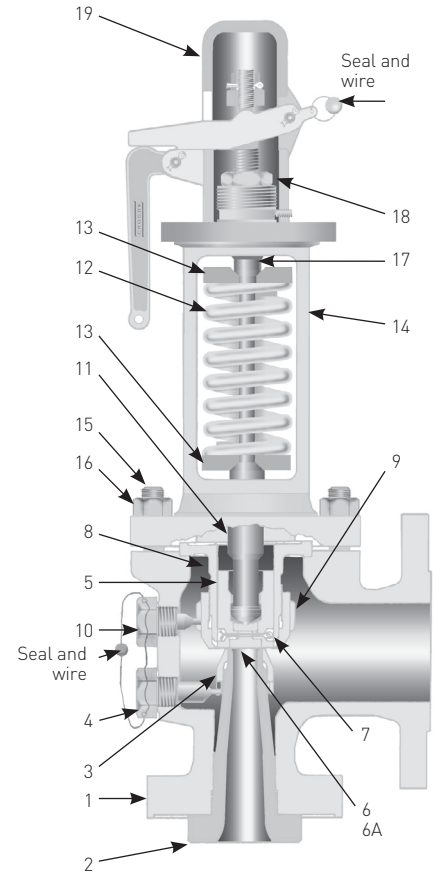

CROSBY H-SERIES

STYLE HSJ

STYLE HSJ CAPS AND LIFTING LEVERS

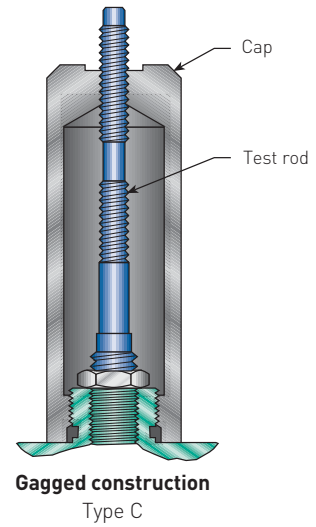
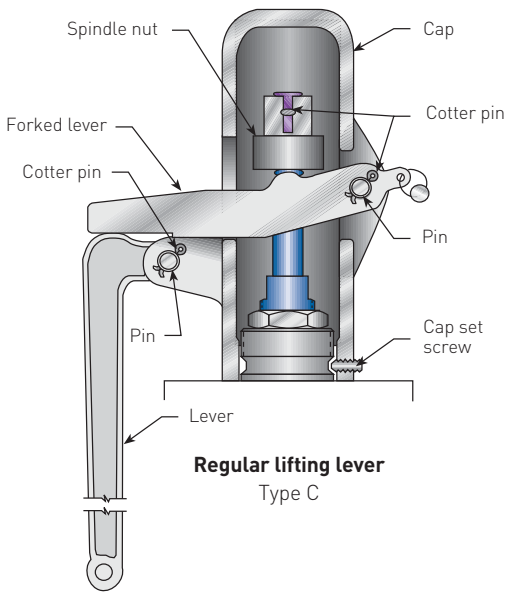
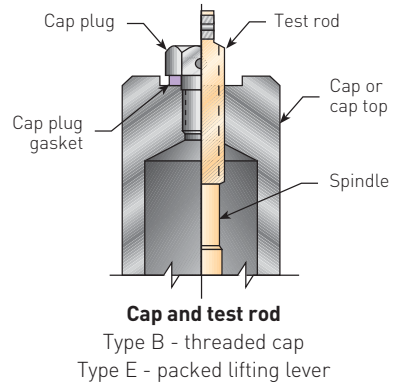
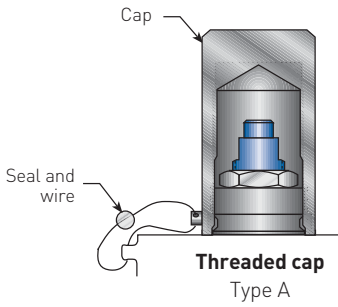

Additional cap furnished for gagging purposes only when requested and ordered by customer

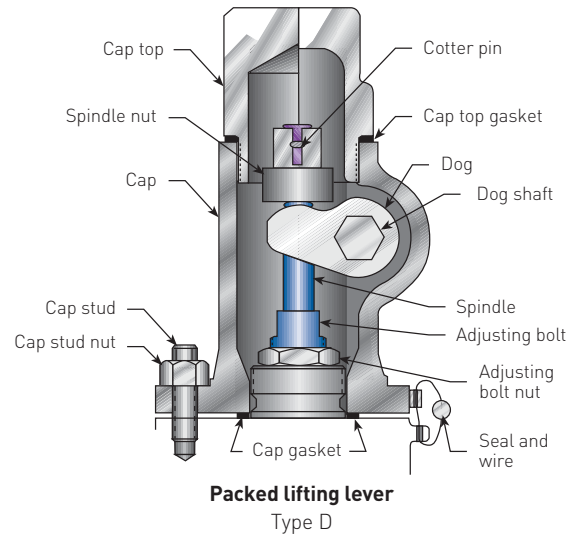
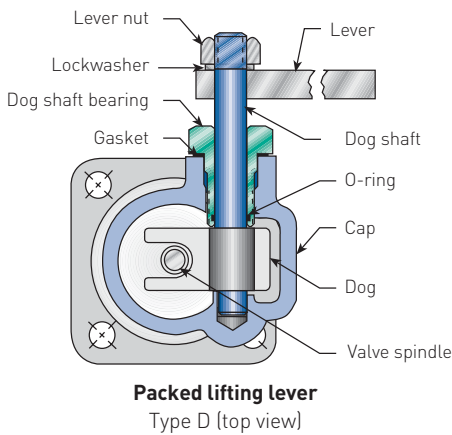

CROSBY H-SERIES

STYLE HSJ

STYLE HSJ - SPECIFICATIONS*

USCS (UNITED STATES CUSTOMARY SYSTEM) UNITS

Valve size inlet x orifice x outlet	Orifice area sq. in. (sq. mm)		Maximum set pressure ^[1] psig (barg)		Style designation		Standard outlet class
					Standard body material and maximum temperature ^[2] flanged		
					SA216 Gr. WCB 750°F (399°C)	SA217 Gr. WC6 1000°F (538°C)	
Class 150 - ANSI raised face flange or welded CL 150 inlet							
1½ F 2	0.307	(198.1)	200	(13.8)	HSJ-16	-	Cl 150
1½ G 2½	0.503	(324.5)	200	(13.8)	HSJ-16	-	Cl 150
1½ H 3	0.785	(506.5)	200	(13.8)	HSJ-16	-	Cl 150
2 J 3	1.288	(831.0)	200	(13.8)	HSJ-16	-	Cl 150
2½ K 4	1.840	(1187.1)	200	(13.8)	HSJ-16	-	Cl 150
3 K 4	1.840	(1187.1)	200	(13.8)	HSJ-16	-	Cl 150
3 L 4	2.853	(1840.6)	200	(13.8)	HSJ-16	-	Cl 150
3 M 6	3.600	(2322.6)	200	(13.8)	HSJ-16	-	Cl 150
4 M 6	3.600	(2322.6)	200	(13.8)	HSJ-16	-	Cl 150
4 N 6	4.341	(2800.6)	200	(13.8)	HSJ-16	-	Cl 150
4 P 6	6.380	(4116.1)	200	(13.8)	HSJ-16	-	Cl 150
6 Q 8	11.045	(7125.8)	165	(11.4)	HSJ-16	-	Cl 150
Class 300 - ANSI raised face flange or welded CL 300 inlet							
1½ F 2	0.307	(198.1)	600	(41.4)	HSJ-46	HSJ-47	Cl 150
1½ G 2½	0.503	(324.5)	600	(41.4)	HSJ-46	HSJ-47	Cl 150
1½ H 3	0.785	(506.5)	600	(41.4)	HSJ-36	HSJ-37	Cl 150
2 J 3	1.288	(831.0)	285	(19.7)	HSJ-26	-	Cl 150
2 J 4	1.288	(831.0)	600	(41.4)	HSJ-36	HSJ-37	Cl 150
2½ J 4	1.288	(831.0)	600	(41.4)	HSJ-36	HSJ-37	Cl 150
2½ K 4	1.840	(1187.1)	600	(41.4)	HSJ-36	HSJ-37	Cl 150
3 K 4	1.840	(1187.1)	600	(41.4)	HSJ-36	HSJ-37	Cl 150
3 L 4	2.853	(1840.6)	600	(41.4)	HSJ-36	HSJ-37	Cl 150
3 M 6	3.600	(2322.6)	600	(41.4)	HSJ-36	HSJ-37	Cl 150
4 M 6	3.600	(2322.6)	600	(41.4)	HSJ-36	HSJ-37	Cl 150
4 N 6	4.341	(2800.6)	600	(41.4)	HSJ-36	HSJ-37	Cl 150
4 P 6	6.380	(4116.1)	600	(41.4)	HSJ-36	HSJ-37	Cl 150
6 Q 8	11.045	(7125.8)	300	(20.7)	HSJ-36	-	Cl 150
6 Q 8	11.045	(7125.8)	165	(11.4)	-	HSJ-37	Cl 150
Class 600 - ANSI raised face flange or welded CL 600 inlet							
1½ F 2	0.307	(198.1)	1095	(75.5)	HSJ-46	HSJ-47	Cl 150
1½ G 2½	0.503	(324.5)	1095	(75.5)	HSJ-46	HSJ-47	Cl 150
1½ H 3	0.785	(506.5)	900	(62.1)	HSJ-46	HSJ-47	Cl 150
2 H 3	0.785	(506.5)	900	(62.1)	HSJ-46	HSJ-47	Cl 150
2 J 4	1.288	(831.0)	1095	(75.5)	HSJ-46	HSJ-47	Cl 150
2½ J 4	1.288	(831.0)	1095	(75.5)	HSJ-46	HSJ-47	Cl 150
2½ K 4	1.840	(1187.1)	1095	(75.5)	HSJ-46	HSJ-47	Cl 150
3 K 4	1.840	(1187.1)	1095	(75.5)	HSJ-46	HSJ-47	Cl 150
3 L 6	2.853	(1840.6)	900	(62.1)	HSJ-46	HSJ-47	Cl 150
4 L 6	2.853	(1840.6)	900	(62.1)	HSJ-46	HSJ-47	Cl 150
3 M 6	3.600	(2322.6)	900	(62.1)	HSJ-46	HSJ-47	Cl 150
4 M 6	3.600	(2322.6)	900	(62.1)	HSJ-46	HSJ-47	Cl 150
4 N 6	4.341	(2800.6)	900	(62.1)	HSJ-46	HSJ-47	Cl 150
4 P 6	6.380	(4116.1)	900	(62.1)	HSJ-46	HSJ-47	Cl 150
6 Q 8	11.045	(7125.8)	600	(41.4)	HSJ-46	HSJ-47	Cl 150

* Select appropriate class to meet pressure/temperature requirements for each application.

Refer to pages 72-75 for pressure/temperature limits for standard class valves per ASME/ANSI B16.34.

CROSBY H-SERIES

STYLE HSJ

STYLE HSJ - SPECIFICATIONS*

USCS (UNITED STATES CUSTOMARY SYSTEM) UNITS

Valve size inlet x orifice x outlet	Orifice area sq. in. (sq. mm)		Maximum set pressure ⁽¹⁾ psig (barg)		Style designation		Standard outlet class
					Standard body material and maximum temperature ⁽²⁾ flanged		
					SA216 Gr. WCB 750°F (399°C)	SA217 Gr. WC6 1000°F (538°C)	
Class 900 - ANSI raised face flange or welded CL 900 inlet							
1½ F 2½	0.307	(198.1)	1970	(135.8)	HSJ-66	HSJ-67	Cl 300
1½ G 2½	0.503	(324.5)	1970	(135.8)	HSJ-66	HSJ-67	Cl 300
1½ H 3	0.785	(506.5)	1610	(111.0)	HSJ-56	HSJ-57	Cl 150
2 H 3	0.785	(506.5)	1610	(111.0)	HSJ-56	HSJ-57	Cl 150
2 J 4	1.288	(831.0)	1600	(110.3)	HSJ-56	HSJ-57	Cl 150
2½ J 4	1.288	(831.0)	1600	(110.3)	-	HSJ-57	Cl 150
3 J 4	1.288	(831.0)	1600	(110.3)	HSJ-56	-	Cl 150
2½ K 4	1.840	(1187.1)	1095	(75.5)	HSJ-56	HSJ-57	Cl 150
3 K 4	1.840	(1187.1)	1095	(75.5)	HSJ-56	HSJ-57	Cl 150
3 L 6	2.853	(1840.6)	900	(62.1)	HSJ-56	HSJ-57	Cl 150
4 L 6	2.853	(1840.6)	900	(62.1)	HSJ-56	HSJ-57	Cl 150
3 M 6	3.600	(2322.6)	900	(62.1)	HSJ-56	HSJ-57	Cl 150
4 M 6	3.600	(2322.6)	900	(62.1)	HSJ-56	HSJ-57	Cl 150
Class 1500 - ANSI raised face flange or welded CL 1500 inlet							
1½ F 2½	0.307	(198.1)	2520	(173.7)	HSJ-66	-	Cl 300
1½ F 2½	0.307	(198.1)	2540	(175.1)	-	HSJ-67	Cl 300
1½ G 2½	0.503	(324.5)	2520	(173.7)	HSJ-66	-	Cl 300
1½ G 2½	0.503	(324.5)	2540	(175.1)	-	HSJ-67	Cl 300
1½ H 3	0.785	(506.5)	2665	(183.8)	HSJ-66	HSJ-67	Cl 300
2 H 3	0.785	(506.5)	2665	(183.8)	HSJ-66	HSJ-67	Cl 300
2 J 4	1.288	(831.0)	1600	(110.3)	HSJ-66	HSJ-67	Cl 300
3 J 4	1.288	(831.0)	1600	(110.3)	HSJ-66	HSJ-67	Cl 300
2½ K 4	1.840	(1187.1)	1095	(75.5)	-	HSJ-67	Cl 150
3 K 4	1.840	(1187.1)	1095	(75.5)	-	HSJ-67	Cl 150
Class 2500 - ANSI raised face flange or welded CL 2500 inlet							
1½ F 2½	0.307	(198.1)	2700	(186.2)	HSJ-76	HSJ-77	Cl 300
2 G 3	0.503	(324.5)	2700	(186.2)	HSJ-76	HSJ-77	Cl 300

* Select appropriate class to meet pressure/temperature requirements for each application.

Refer to pages 72-75 for pressure/temperature limits for standard class valves per ASME/ANSI B16.34.

NOTES

- Set pressure is limited to either the inlet flange pressure limit per ASME/ANSI B16.34 (pages 72-75) or the maximum set pressure, whichever is lower.
- SA-217 Gr. WC6 is Crosby's standard high temperature material. SA-217 Gr. WC9 is available as an alternative.

CROSBY H-SERIES

STYLE HSJ

STYLE HSJ - DIMENSIONS AND WEIGHTS

USCS (UNITED STATES CUSTOMARY SYSTEM) UNITS

Valve size inlet x orifice x outlet	HSJ valve style ⁽¹⁾	Inlet ID ⁽¹⁾ A	Center-to-face		Used to find bolt length ⁽³⁾ X	Approx. height ⁽²⁾ Valve (cap) type			Approx. weight Type C (lbs)
			Inlet C	Outlet D		A/B	C	D/E	
Class 150 - ANSI raised face flange or welded CL 150 inlet									
1½ F 2	16	1½	4⅞	4¾	1¾	20¼	22½	23¼	50
1½ G 2½	16	1½	4⅞	4¾	1¾	20¼	22½	23¼	50
1½ H 3	16	1½	5⅞	4⅞	1 ¹¹ / ₁₆	20½	22¾	23½	50
2 J 3	16	2	5¾	4⅞	1 ¹¹ / ₁₆	21	23¼	24	65
2½ K 4	16	2½	6⅞	6⅞	1⅞	26	29¼	30	110
3 K 4	16	3	6⅞	6⅞	2⅞	26	29¼	30	115
3 L 4	16	3	6⅞	6½	2	30¼	33½	34¼	150
3 M 6	16	3	7	7¼	1 ¹³ / ₁₆	29¾	33	33¾	192
4 M 6	16	4	7	7¼	2⅞	29¾	33	33¾	200
4 N 6	16	4	7¾	8¼	2⅞	37¾	42¼	43	260
4 P 6	16	4	7⅞	9	2⅞	37	41½	42¼	270
6 Q 8	16	6	9 ⁷ / ₁₆	9½	2 ⁵ / ₁₆	42¼	46¾	47½	475
Class 300 - ANSI raised face flange or welded CL 300 inlet									
1½ F 2	4()	1½	4⅞	6	1¾	20¼	22½	23¼	50
1½ G 2½	4()	1½	4⅞	6	1¾	20¼	22½	23¼	50
1½ H 3	3()	1½	5⅞	4⅞	1 ¹¹ / ₁₆	20½	22¾	23½	55
2 J 3	26	2	5¾	4⅞	1 ¹¹ / ₁₆	21	23¼	24	65
2 J 4	3()	2	5⅞	5⅞	1⅞	23½	26¾	27½	83
2½ J 4	3()	2½	5¾	5⅞	2 ¹ / ₁₆	23	26¼	27	90
2½ K 4	3()	2½	6⅞	6⅞	1⅞	26	29¼	30	110
3 K 4	3()	3	6⅞	6⅞	2⅞	26	29¼	30	115
3 L 4	3()	3	6⅞	6½	2	30¼	33½	34¼	150
3 M 6	3()	3	7½	7¼	2⅞	32¾	36	36¾	215
4 M 6	3()	4	7	7¼	2⅞	32¼	35½	36¼	225
4 N 6	3()	4	7¾	8¼	2⅞	37¾	42¼	43	270
4 P 6	3()	4	8⅞	10	2⅞	38¾	43¼	44	290
6 Q 8	3()	6	9 ⁷ / ₁₆	9½	2 ⁵ / ₁₆	42¼	46¾	47½	495
Class 600 - ANSI raised face flange or welded CL 600 inlet									
1½ F 2	4()	1½	4⅞	6	1¾	20¼	22½	23¼	50
1½ G 2½	4()	1½	4⅞	6	1¾	20¼	22½	23¼	50
1½ H 3	4()	1½	5⅞	4⅞	1 ¹³ / ₁₆	20½	22¾	23½	55
2 H 3	4()	2	5⅞	4⅞	1 ¹³ / ₁₆	20½	22¾	23½	60
2 J 4	4()	2	6⅞	6¾	1⅞	25¾	29	29¾	106
2½ J 4	4()	2½	6⅞	6¾	2⅞	25¾	29	29¾	115
2½ K 4	4()	2½	7¼	7⅞	2	29¼	32½	33¼	155
3 K 4	4()	3	7¼	7⅞	2⅞	29¼	32½	33¼	160
3 L 6	4()	3	8	8	2⅞	32½	35¾	36½	205
4 L 6	4()	4	7 ¹ / ₁₆	8	2⅞	31½	34¾	35½	225
3 M 6	4()	3	7½	7¼	2⅞	32¾	36	36¾	215
4 M 6	4()	4	7	8	2 ⁷ / ₁₆	32¼	35½	36¼	225
4 N 6	4()	4	7¾	8¾	2⅞	37¾	42¼	43	285
4 P 6	4()	4	8⅞	10	2 ⁹ / ₁₆	41	45½	46¼	405
6 Q 8	4()	6	9 ⁷ / ₁₆	9½	2 ¹⁵ / ₁₆	46¼	50¾	51½	570

CROSBY H-SERIES

STYLE HSJ

STYLE HSJ - DIMENSIONS AND WEIGHTS

USCS (UNITED STATES CUSTOMARY SYSTEM) UNITS

Valve size inlet x orifice x outlet	HSJ valve style ^[1]	General dimensions - inches							Approx. weight Type C (lbs)
		Inlet ID ^[1] A	Center-to-face		Used to find bolt length ^[3] X	Approx. height ^[2] Valve (cap) type			
			Inlet C	Outlet D		A/B	C	D/E	
Class 900 - ANSI raised face flange or welded CL 900 inlet									
1½ F 2½	6 ()	1½	4⅞	6	2	20	22¼	23	65
1½ G 2½	6 ()	1½	4⅞	6	2	22¼	25¼	26¼	70
1½ H 3	5 ()	1½	6⅞/16	6⅞	2⅞/16	25	28	28¾	94
2 H 3	5 ()	2	6⅞/16	6⅞	2⅞/8	24½	27½	28¼	110
2 J 4	56	2	7¼	7⅞	2⅞/8	29	32¼	33	130
2 J 4	57	2	6⅞	6¾	2⅞/8	25¾	29	29¾	115
2½ J 4	57	2½	6⅞	6¾	2½	25¾	29	29¾	140
3 J 4	56	3	7¼	7⅞	2¾	29	32¼	33	155
2½ K 4	5 ()	2½	7¼	7⅞	2½	29¼	32½	33¼	170
3 K 4	5 ()	3	7¼	7⅞	2⅞/16	29¼	32½	33¼	175
3 L 6	5 ()	3	8	8	2⅞/8	32½	35¾	36½	210
4 L 6	5 ()	4	7¾	8¾	2⅞/8	32¼	35½	36¼	230
3 M 6	5 ()	3	7¾	7¼	2⅞/8	33	36½	37¼	220
4 M 6	5 ()	4	7¾	8¾	2⅞/16	33	36¼	37	230
Class 1500 - ANSI raised face flange or welded CL 1500 inlet									
1½ F 2½	6 ()	1½	4⅞	6	2	20	22¼	23	65
1½ G 2½	6 ()	1½	4⅞	6	2	22¼	25¼	26¼	70
1½ H 3	6 ()	1½	6⅞/16	6⅞	2⅞/16	25	28	28¾	96
2 H 3	6 ()	2	6⅞/16	6⅞	2⅞/8	24½	27½	28¼	110
2 J 4	6 ()	2	7¼	7⅞	2⅞/8	29	32¼	33	130
3 J 4	6 ()	3	7¼	7⅞	2¾	29	32¼	33	155
2½ K 4	67	2½	7¼	7⅞	2½	29¼	32½	33¼	170
3 K 4	67	3	7¼	7⅞	2¾	29¼	32½	33¼	175
Class 2500 - ANSI raised face flange or welded CL 2500 inlet									
1½ F 2½	7 ()	1½	5½	6½	2½	20¾	23	23¾	65
2 G 3	7 ()	2	6⅞	6¾	2¾	23¼	26½	27¼	70

NOTES

- Safety valves must be mounted on a nozzle with an inlet diameter equal to or greater than the nominal valve inlet size, dimension A. See ASME boiler and pressure code Section I and ANSI/ASME B31.1 for recommended installation.
 - Dismantling height: an additional 20 inches (508 mm) is required.
 - Bolt holes straddle center line.
- Drain: body drain is ½" NPT for F-N orifices
¾" NPT for P and Q orifices

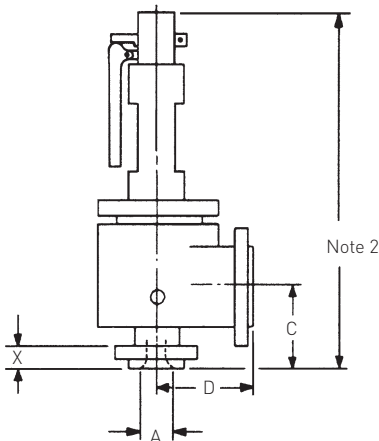

CROSBY H-SERIES

STYLE HSJ

STYLE HSJ - DIMENSIONS AND WEIGHTS

METRIC UNITS

Valve size inlet x orifice x outlet	HSJ valve style ^[1]	General dimensions - millimeters							Approx. weight Type C (kg)
		Inlet ID ^[1] A	Center-to-face Inlet C Outlet D		Used to find bolt length ^[3] X	Approx. height ^[2] Valve (cap) type A/B C D/E			
Class 150 - ANSI raised face flange or welded CL 150 inlet									
1½ F 2	16	38.1	123.8	120.7	44.5	514.4	571.5	590.6	23
1½ G 2½	16	38.1	123.8	120.7	44.5	514.4	571.5	590.6	23
1½ H 3	16	38.1	130.2	123.8	42.9	520.7	577.9	596.9	23
2 J 3	16	50.8	136.5	123.8	42.9	533.4	590.6	609.6	29
2½ K 4	16	63.5	155.6	161.9	47.6	660.4	743.0	762.0	50
3 K 4	16	76.2	155.6	161.9	54.0	660.4	743.0	762.0	52
3 L 4	16	76.2	155.6	165.1	50.8	768.4	850.9	870.0	68
3 M 6	16	76.2	177.8	184.2	46.0	755.7	838.2	857.3	87
4 M 6	16	101.6	177.8	184.2	54.0	755.7	838.2	857.3	91
4 N 6	16	101.6	196.9	209.6	54.0	958.9	1073.2	1092.2	118
4 P 6	16	101.6	181.0	228.6	54.0	938.8	1054.1	1079.5	123
6 Q 8	16	152.4	239.7	241.3	58.7	1073.2	1187.5	1206.5	216
Class 300 - ANSI raised face flange or welded CL 300 inlet									
1½ F 2	4()	38.1	123.8	152.4	44.5	514.4	571.5	590.6	23
1½ G 2½	4()	38.1	123.8	152.4	44.5	514.4	571.5	590.6	23
1½ H 3	3()	38.1	130.2	123.8	42.9	520.7	577.9	596.9	25
2 J 3	26	50.8	136.5	123.8	42.9	533.4	590.6	609.6	29
2 J 4	3()	50.8	149.2	142.9	47.6	596.9	679.5	698.5	38
2½ J 4	3()	63.5	136.5	142.9	52.4	584.2	666.8	685.8	41
2½ K 4	3()	63.5	155.6	161.9	47.6	660.4	743.0	762.0	50
3 K 4	3()	76.2	155.6	161.9	54.0	660.4	743.0	762.0	52
3 L 4	3()	76.2	155.6	165.1	50.8	768.4	850.9	870.0	68
3 M 6	3()	76.2	190.5	184.2	54.0	831.9	914.4	933.5	98
4 M 6	3()	101.6	177.8	184.2	54.0	819.2	901.7	920.8	102
4 N 6	3()	101.6	196.9	209.6	54.0	958.9	1073.2	1092.2	123
4 P 6	3()	101.6	225.4	254.0	54.0	984.3	1098.6	1117.6	132
6 Q 8	3()	152.4	239.7	241.3	58.7	1073.2	1187.5	1206.5	225
Class 600 - ANSI raised face flange or welded CL 600 inlet									
1½ F 2	4()	38.1	123.8	152.4	44.5	514.4	571.5	590.6	23
1½ G 2½	4()	38.1	123.8	152.4	44.5	514.4	571.5	590.6	23
1½ H 3	4()	38.1	130.2	123.8	46.0	520.7	577.9	596.9	25
2 H 3	4()	50.8	130.2	123.8	46.0	520.7	577.9	596.9	27
2 J 4	4()	50.8	155.6	171.5	47.6	654.1	736.6	755.7	48
2½ J 4	4()	63.5	155.6	171.5	54.0	654.1	736.6	755.7	52
2½ K 4	4()	63.5	184.2	181.0	50.8	743.0	825.5	844.6	70
3 K 4	4()	76.2	184.2	181.0	54.0	743.0	825.5	844.6	73
3 L 6	4()	76.2	203.2	203.2	54.0	825.5	908.1	927.1	93
4 L 6	4()	101.6	179.4	203.2	60.3	800.1	882.7	901.7	102
3 M 6	4()	76.2	190.5	184.2	54.0	831.9	914.4	933.5	98
4 M 6	4()	101.6	177.8	203.2	61.9	819.2	901.7	920.8	102
4 N 6	4()	101.6	196.9	222.3	60.3	958.9	1073.2	1092.2	129
4 P 6	4()	101.6	225.4	254.0	65.1	1041.4	1155.7	1174.8	184
6 Q 8	4()	152.46	239.7	241.3	74.6	1174.8	1289.1	1308.1	259

CROSBY H-SERIES

STYLE HSJ

STYLE HSJ - DIMENSIONS AND WEIGHTS

METRIC UNITS

Valve size inlet x orifice x outlet	HSJ valve style ^[1]	General dimensions - millimeters							Approx. weight Type C (kg)	
		Inlet ID ^[1] A	Center-to-face Inlet C Outlet D		Used to find bolt length ^[3] X	Approx. height ^[2] Valve (cap) type A/B C D/E				
Class 900 - ANSI raised face flange or welded CL 900 inlet										
1½ F 2½	6 ()	38.1	123.8	152.4	50.8	508.0	565.2	584.2	29	
1½ G 2½	6 ()	38.1	123.8	152.4	50.8	565.2	641.4	666.8	32	
1½ H 3	5 ()	38.1	166.7	161.9	52.4	635.0	711.2	730.3	43	
2 H 3	5 ()	50.8	154.0	161.9	60.3	622.3	698.5	717.6	50	
2 J 4	56	50.8	184.2	181.0	60.3	736.6	819.2	838.2	59	
2 J 4	57	50.8	155.6	171.5	60.3	654.1	736.6	755.7	52	
2½ J 4	57	63.5	155.6	171.5	63.5	654.1	736.6	755.7	64	
3 J 4	56	76.2	184.2	181.0	69.9	736.6	819.2	838.2	70	
2½ K 4	5 ()	63.5	184.2	181.0	63.5	743.0	825.5	844.6	77	
3 K 4	5 ()	76.2	184.2	181.0	61.9	743.0	825.5	844.6	79	
3 L 6	5 ()	76.2	203.2	203.2	60.3	825.5	908.1	927.1	95	
4 L 6	5 ()	101.6	196.9	222.3	66.7	819.2	901.7	920.8	104	
3 M 6	5 ()	76.2	196.9	184.2	60.3	838.2	927.1	946.2	100	
4 M 6	5 ()	101.6	196.9	222.3	65.1	838.2	920.8	939.8	104	
Class 1500 - ANSI raised face flange or welded CL 1500 inlet										
1½ F 2½	6 ()	38.1	123.8	152.4	50.8	508.0	565.2	584.2	29	
1½ G 2½	6 ()	38.1	123.8	152.4	50.8	565.2	641.4	666.8	32	
1½ H 3	6 ()	38.1	166.7	161.9	52.4	635.0	711.2	730.3	44	
2 H 3	6 ()	50.8	154.0	161.9	60.3	622.3	698.5	717.6	50	
2 J 4	6 ()	50.8	184.2	181.0	60.3	736.6	819.2	838.2	59	
3 J 4	6 ()	76.2	184.2	181.0	69.9	736.6	819.2	838.2	70	
2½ K 4	67	63.5	184.2	181.0	63.5	743.0	825.5	844.6	77	
3 K 4	67	76.2	184.2	181.0	69.9	743.0	825.5	844.6	79	
Class 2500 - ANSI raised face flange or welded CL 2500 inlet										
1½ F 2½	7 ()	38.1	139.7	165.1	63.5	527.1	584.2	603.3	29	
2 G 3	7 ()	50.8	155.6	171.5	69.9	590.6	673.1	692.2	32	

NOTES

- Safety valves must be mounted on a nozzle with an inlet diameter equal to or greater than the nominal valve inlet size, dimension A. See ASME boiler and pressure code Section I and ANSI/ASME B31.1 for recommended installation.
 - Dismantling height: an additional 20 inches (508 mm) is required.
 - Bolt holes straddle center line.
- Drain: body drain is ½" NPT for F-N orifices
¾" NPT for P and Q orifices

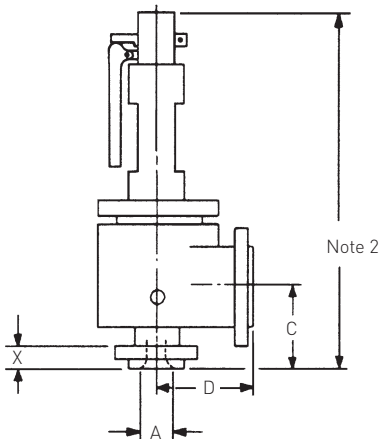

CROSBY H-SERIES

STYLE HSL DIRECT SPRING SAFETY VALVE

STYLE HSL

The Style HSL is a high capacity full nozzle reaction type flanged steel safety valve designed for saturated and superheated steam service up to 725 psig (50 barg) and 1000°F (538°C).

FEATURES

- Increases Operating Efficiency
 - FLEXI-DISC seat design is recessed for pressure and temperature equalization, ensuring a flat and tight seal.
 - FLEXI-DISC seat tightness up to 93%. For seat tightness greater than 93% consult factory.
 - Meets the requirements of ASME Code Section I, Power Boilers and Section VIII for steam service.
 - May also be used for ASME VIII off boiler steam applications for higher operating pressures.
- Reduces Maintenance Costs
 - Replaceable full nozzle design requiring no special tools facilitates ease of maintenance and longer service life.
 - Single bonnet design allows set pressure changes simply by changing-out the spring.
- Minimizes Installation Costs
 - High discharge coefficient results in the most economical valve selection.

TECHNICAL DATA

Sizes:	1¼" x 1½" to 6" x 8" (DN 32 x DN 40 to DN 150 x DN 200)
Connections:	Flanged inlet to ASME Classes 300 and 600
Temperature rating: Max set pressure:	To 1000°F (538°C) 725 psig (50 barg)
Codes:	ASME I and VIII



CROSBY H-SERIES

STYLE HSL

PRODUCT OVERVIEW

The HSL's adjustable nozzle ring and guide ring (Figure 1) utilize the reactive and expansive forces of flowing steam to provide full lift. With a high K x A, positive overpressure protection is achieved with the fewest valves.

The two-ring design provides precise blowdown control, which can be adjusted while the valve is installed in the system.

Style HSL safety valves incorporate the FLEXI-DISC design. Centering of the disc through a low friction guide ensures the valve opens precisely at set pressure, even after repeated cycling.

There is a choice of inlet flange ratings: The set pressure range for Cl300# valves is 15 psig (1.034 barg) to 330 psig (22.75 barg) and 15 psig (1.034 barg) to 725 psig (50 barg) for Cl600#.

Style HSL safety valves are available with optional test gags, weatherhoods for outdoor applications and Class 150# drip pan elbows. A ring-type joint inlet connection is also available. The entire HSL range of F through Q orifices uses a full nozzle design (Figure 1) to facilitate removal and ease of maintenance.

Certification and type approvals

- ASME Boiler and Pressure Vessel Code Section I and VIII
- National Board of Boiler and Pressure Vessel Inspectors Capacity Certifications
- Canadian Registration Number
- Pressure Equipment Directive (97/27/EC) (ISO 4126-1) (CE)
- China Manufacturing License (TS)

BILL OF MATERIALS (F THRU J ORIFICE)

Part ref. No.	Part name	Material and maximum temperature	
		750°F (399°C)	1000°F (538°C)
1	Body	Carbon steel SA-216 Gr. WCB/WCC	Alloy steel SA-217 Gr. WC6
2	Nozzle	Stainless steel	Stainless steel
3	Drain plug	Carbon steel	Carbon steel
4	Nozzle ring	Stainless steel	Stainless steel
5	Nozzle ring set screw	Stainless steel	Stainless steel
6	Disc*	Stainless steel	Stainless steel
7	Guide	Monel®	Nickel alloy
8	Guide ring	Stainless steel	Stainless steel
9	Guide ring set screw	Stainless steel	Stainless steel
10	Bonnet stud nut	SA-194 Gr. 2H	SA-194 Gr. 2H
11	Bonnet stud	SA-193 Gr. B7	SA-193 Gr. B7
12	Spring washers	Carbon steel	Steel
13	Bonnet	Carbon steel SA-216 Gr. WCB/WCC	Alloy steel SA-217 Gr. WC6
14	Spindle	Stainless steel	Stainless steel
15	Adjusting bolt	Stainless steel	Stainless steel
16	Adjusting bolt nut	Steel	Steel
17	Cap	Iron	Iron
18	Cap set screw	Stainless steel	Stainless steel
19	Lever	Iron	Iron
20	Forked lever	Iron	Iron
21	Spindle nut	Steel	Steel
22	Spindle nut cotter pin	Steel	Steel
23	Cotter pin	Steel	Steel
24	Forked lever pin	Steel	Steel
28	Spring	Alloy steel Corrosion resistant coating**	Alloy steel Corrosion resistant coating**
29	Lever pin	Steel	Steel
30	Cotter pin	Steel	Steel
***	Nameplate	Stainless steel	Stainless steel

* Recommended spare part

** Crosby may upgrade to Inconel® X 750

*** Not shown

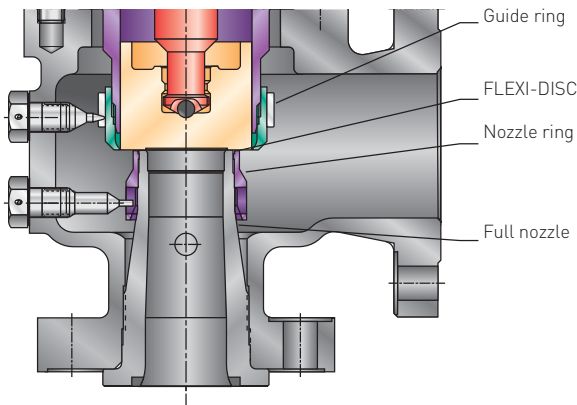
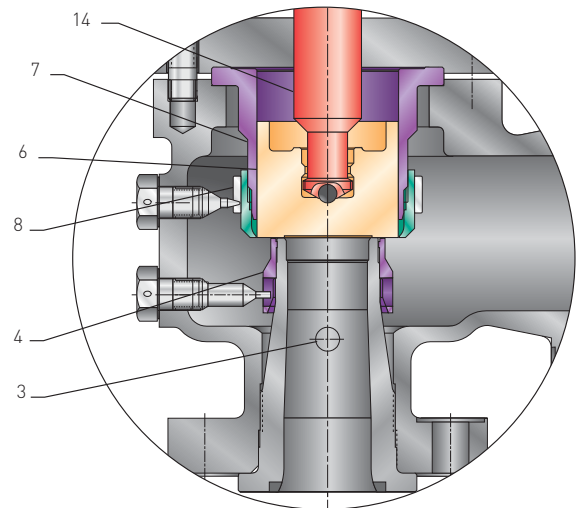

FIGURE 1 - HSL FULL NOZZLE



F - J ORIFICE CONSTRUCTION

CROSBY H-SERIES

STYLE HSL

F THRU J ORIFICE

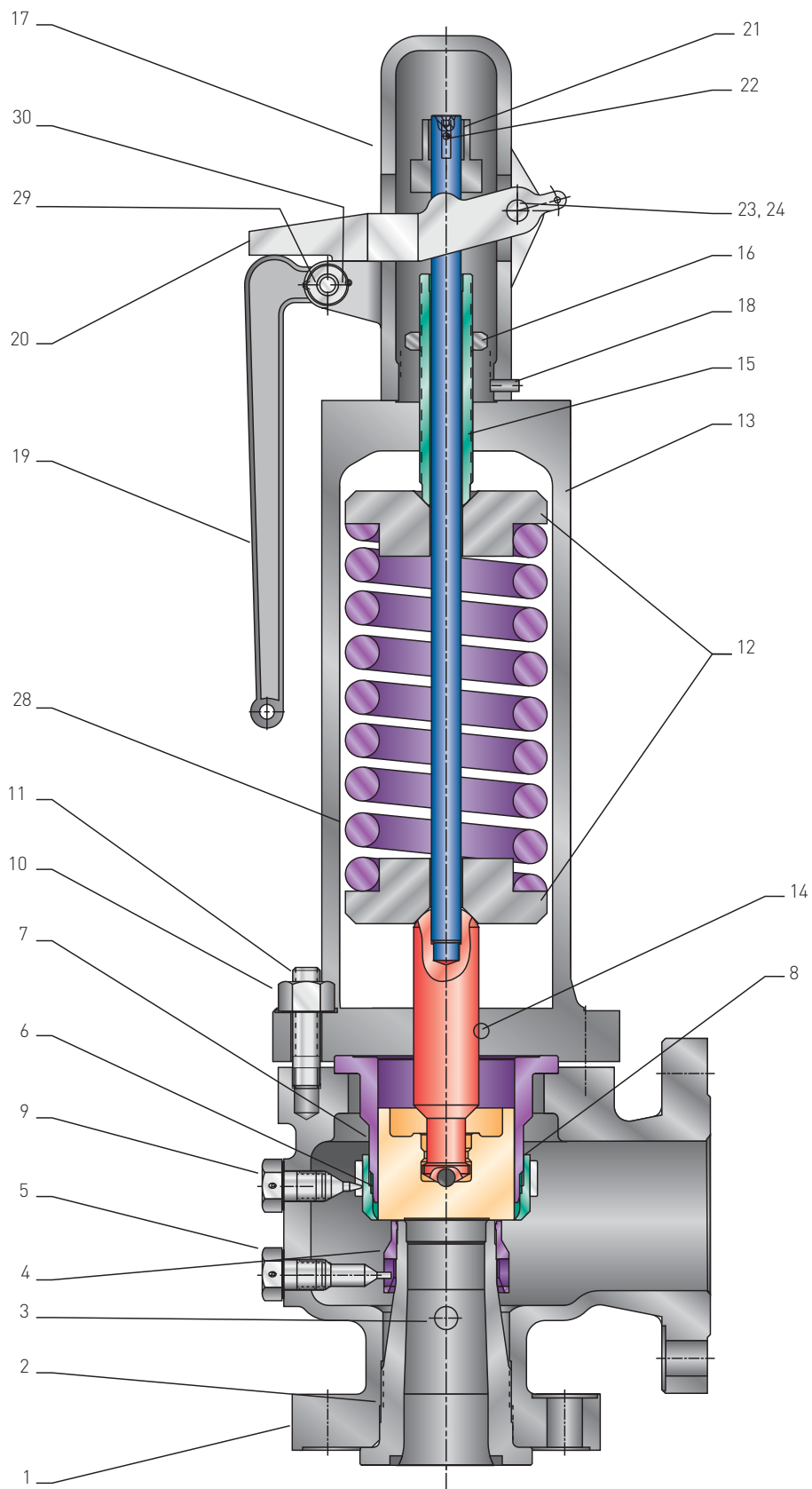

CROSBY H-SERIES

STYLE HSL

BILL OF MATERIALS (K THRU Q ORIFICE)

Part ref. no.	Part name	Material and maximum temperature	
		750°F (399°C)	1000°F (538°C)
1	Body	Carbon steel SA-216 Gr. WCB/WCC	Alloy steel SA-217 Gr. WC6
2	Nozzle	Stainless steel	Stainless steel
3	Drain plug	Carbon steel	Carbon steel
4	Nozzle ring	Stainless steel	Stainless steel
5	Nozzle ring set screw	Stainless steel	Stainless steel
6	Disc insert*	Stainless steel	Stainless steel
7A and B	Disc holder and bushing	Monel®/Stainless steel	Nickel alloy
9	Disc insert cotter pin*	Stainless steel	Stainless steel
10	Guide	Monel®	Nickel alloy
11	Guide ring	Stainless steel	Stainless steel
12	Guide ring set screw	Stainless steel	Stainless steel
13	Bonnet stud nut	SA-194 Gr. 2H	SA-194 Gr. 2H
14	Bonnet stud	SA-193 Gr. B7	SA-193 Gr. B7
15	Spring washers	Carbon steel	Steel
16	Bonnet	Carbon steel SA-216 Gr. WCB/WCC	Alloy steel SA-217 Gr. WC6
17	Spindle	Stainless steel	Stainless steel
18	Adjusting bolt	Stainless steel	Stainless steel
19	Adjusting bolt nut	Steel	Steel
20	Cap	Iron	Iron
21	Cap set screw	Stainless steel	Stainless steel
22	Lever	Iron	Iron
23	Forked lever	Iron	Iron
24	Spindle nut	Steel	Steel
25	Spindle nut cotter pin	Steel	Steel
26	Cotter pin	Steel	Steel
27	Forked lever pin	Steel	Steel
28	Spring	Alloy steel Corrosion resistant coating	Alloy steel Corrosion resistant coating
32	Lever pin	Steel	Steel
33	Cotter pin	Steel	Steel
**	Nameplate	Stainless steel	Stainless steel

* Recommended spare parts

** Not shown

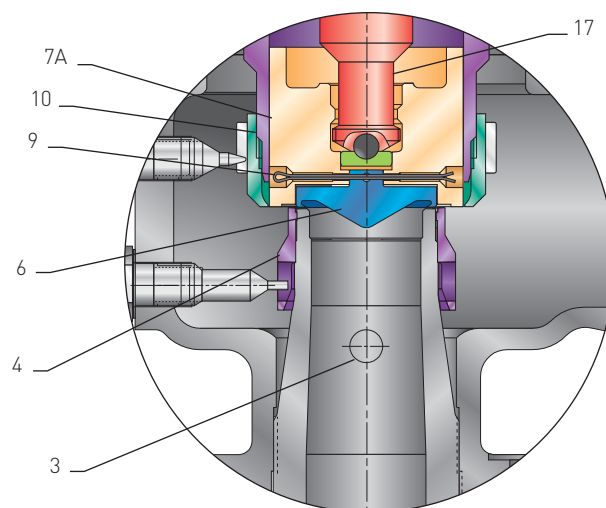

K - Q ORIFICE CONSTRUCTION

CROSBY H-SERIES

STYLE HSL

K THRU Q ORIFICE

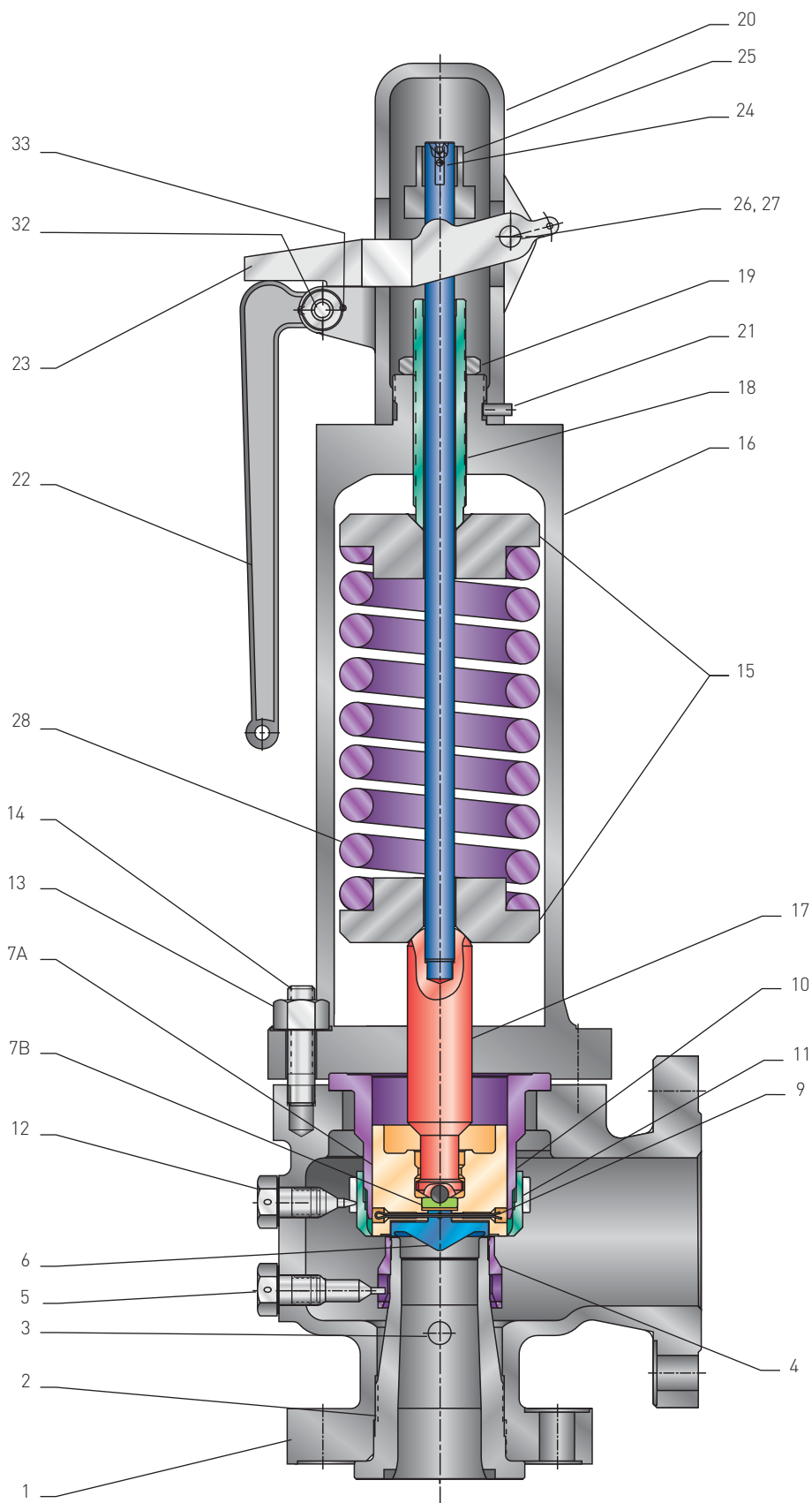

CROSBY H-SERIES

STYLE HSL

LIFT LEVER AND ACCESSORIES

REGULAR LIFTING LEVER TYPE C (standard)

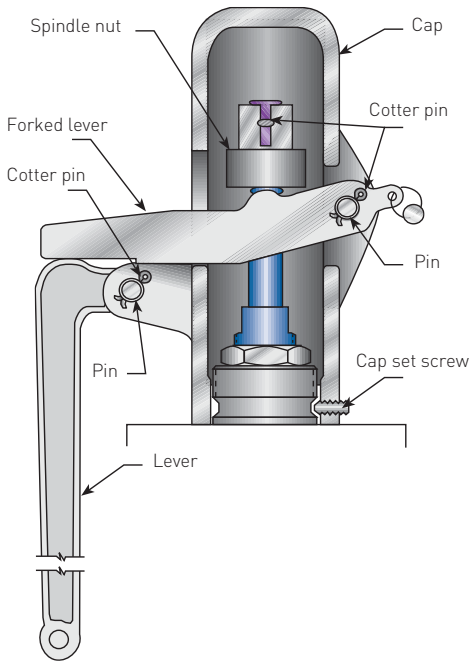

OPTIONAL TEST GAG TYPE C

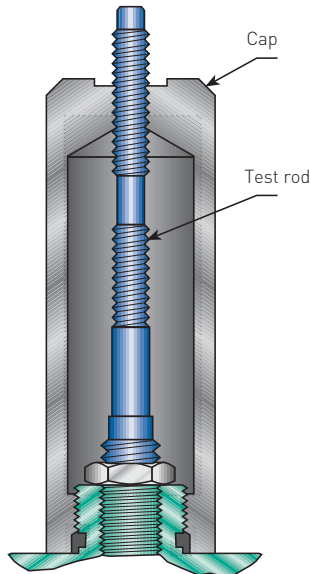

Additional cap furnished for gagging purposes only when requested and ordered by customer

SAFETY VALVE WITH OPTIONAL WEATHERHOOD FOR OUTDOOR SERVICE

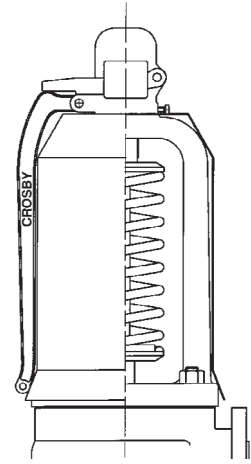

OPTIONAL DRIP PAN ELBOWS

For optimum safety valve performance, discharge piping should be supported independently of the valve. This can best be accomplished by installing a slip joint arrangement at the inlet to the riser pipe, using a drip pan elbow.

The riser should be sized sufficiently larger than the slip joint to provide clearance during expansion of the boiler and should be located with enough clearance at the lower end to prevent 'bottoming' on the drip pan. Drain lines should be installed from the discharge elbow and the safety valve body and piped separately from any other drain or vent line.

The size of the drip pan elbow should be at least equal to that of the safety valve outlet size.

The flanged model EFS drip pan elbow should be used without any intermediary connection.

Specifications

Model: EFS
 Sizes: 1½", 2½", 3", 4", 6", 8"
 Flange ANSI Class: 150 (1½" to 8")
 Material: Carbon steel

DIMENSIONS (inches)

Valve outlet size	A	B	C	D	E 150 ANSI Class	F
1½	7	2½	2½	6	4 ¹¹ / ₁₆	9
2½	9	2½	3	7	6½	10¾
3	9	3	3	8	7¼	12½
4	12	3	4	8	9	14
6	14	4	5	8	12½	17
8	16	4	6½	8	12	16

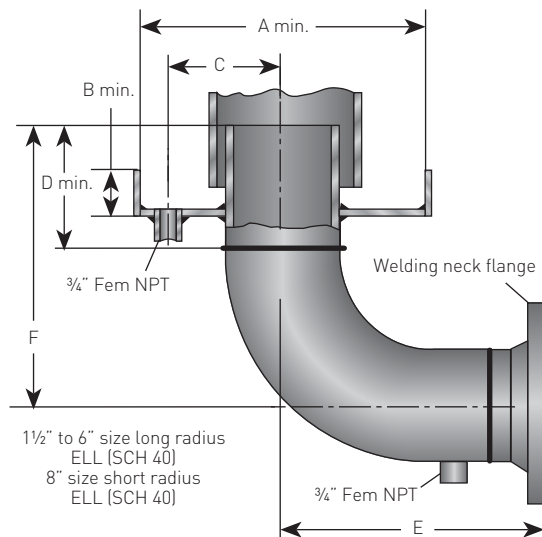

CROSBY H-SERIES

STYLE HSL

STYLE HSL - DIMENSIONS AND WEIGHTS

CL 300 - ANSI RAISED FACE FLANGE

Valve size inlet orifice outlet	HSL valve style	Center-to-face			Used to find bolt Length 'X' ⁽¹⁾ in (mm)	Approx. height 'D' in (mm)	Drain height 'E' in (mm)	NPT drain size	Approx. weight lb (kg)
		Inlet ID 'A' in (mm)	Inlet 'B' in (mm)	Outlet 'C' in (mm)					
1 1/4 F 1 1/2	3 ()	1 1/4 (31.8)	4 13/32 (111.9)	4 3/16 (106.4)	1 3/16 (30.2)	21 1/2 (546)	2 11/16 (68)	1/4	41 (18.6)
1 1/4 G 1 1/2	3 ()	1 1/4 (31.8)	4 13/32 (111.9)	4 3/16 (106.4)	1 3/16 (30.2)	21 1/2 (546)	2 11/16 (68)	1/4	41 (18.6)
1 1/2 H 2 1/2	3 ()	1 1/2 (38.1)	4 3/4 (120.7)	4 7/8 (123.8)	1 1/4 (31.75)	22 1/4 (565)	2 5/8 (66)	3/8	56 (25.4)
1 1/2 J 2 1/2	3 ()	1 1/2 (38.1)	4 3/4 (120.7)	4 7/8 (123.8)	1 1/4 (31.75)	26 3/4 (679)	2 5/8 (66)	3/8	71 (32.2)
2 K 3	3 ()	2 (50.8)	5 1/4 (133.4)	5 9/16 (141.3)	1 1/2 (38.1)	30 1/8 (765)	3 1/8 (80)	3/8	90 (40.8)
2 1/2 L 4	3 ()	2 1/2 (63.5)	6 1/8 (155.6)	6 5/16 (160.3)	1 13/16 (46)	32 7/8 (835)	3 7/8 (98)	1/2	138 (62.6)
3 M 4	3 ()	3 (76.2)	6 1/2 (165.1)	6 7/16 (163.5)	1 7/8 (47.6)	33 3/16 (852)	4 3/16 (107)	1/2	156 (70.8)
4 N 6	3 ()	4 (101.6)	7 1/4 (184.2)	7 7/16 (188.9)	2 1/8 (54)	40 3/4 (1035)	4 1/4 (108)	3/4	261 (118.4)
4 P 6	3 ()	4 (101.6)	7 7/16 (188.9)	8 3/16 (207.9)	2 1/8 (54)	41 1/4 (1048)	4 7/16 (113)	3/4	281 (127.5)
6 QQ 8	3 ()	6 (152.4)	9 7/8 (250.8)	9 9/16 (238.1)	2 1/2 (63.5)	47 1/16 (1195)	4 13/16 (122)	3/4	494 (224.1)

CL 600 - ANSI RAISED FACE FLANGE

Valve size inlet orifice outlet	HSL valve style	Center-to-face			Used to find bolt Length 'X' ⁽¹⁾ in (mm)	Approx. height 'D' in (mm)	Drain height 'E' in (mm)	NPT drain size	Approx. weight lb (kg)
		Inlet ID 'A' in (mm)	Inlet 'B' in (mm)	Outlet 'C' in (mm)					
1 1/4 F 1 1/2	4 ()	1 1/4 (31.8)	4 13/32 (111.9)	4 3/16 (106.4)	1 3/16 (30.2)	21 1/2 (546)	2 11/16 (68)	1/4	41 (18.6)
1 1/4 G 1 1/2	4 ()	1 1/4 (31.8)	4 13/32 (111.9)	4 3/16 (106.4)	1 3/16 (30.2)	21 1/2 (546)	2 11/16 (68)	1/4	41 (18.6)
1 1/2 H 2 1/2	4 ()	1 1/2 (38.1)	4 3/4 (120.7)	4 7/8 (123.8)	1 1/4 (31.75)	22 1/4 (565)	2 5/8 (66)	3/8	56 (25.4)
1 1/2 J 2 1/2	4 ()	1 1/2 (38.1)	4 3/4 (120.7)	4 7/8 (123.8)	1 1/4 (31.75)	26 3/4 (679)	2 5/8 (66)	3/8	72 (32.7)
2 K 3	4 ()	2 (50.8)	5 1/4 (133.4)	5 9/16 (141.3)	1 1/2 (38.1)	30 1/8 (765)	3 1/8 (80)	3/8	90 (40.8)
2 1/2 L 4	4 ()	2 1/2 (63.5)	6 1/8 (155.6)	6 5/16 (160.3)	1 13/16 (46)	32 7/8 (835)	3 7/8 (98)	1/2	138 (62.6)
3 M 4	4 ()	3 (76.2)	6 1/2 (165.1)	6 7/16 (163.5)	1 7/8 (47.6)	33 3/16 (852)	4 3/16 (107)	1/2	156 (70.8)
4 N 6	4 ()	4 (101.6)	7 11/16 (195.2)	7 7/16 (188.9)	2 7/16 (62)	41 3/8 (1051)	4 3/4 (121)	3/4	261 (118.4)
4 P 6	4 ()	4 (101.6)	7 11/16 (195.2)	8 3/16 (207.9)	2 7/16 (62)	41 1/2 (1054)	4 3/4 (121)	3/4	298 (135.2)
6 QQ 8	4 ()	6 (152.4)	10 5/16 (261.9)	9 9/16 (238.1)	2 7/8 (73)	51 1/2 (1309)	5 3/8 (137)	3/4	494 (224.1)

NOTE

1. Bolt holes straddle centerline on flanged connections.

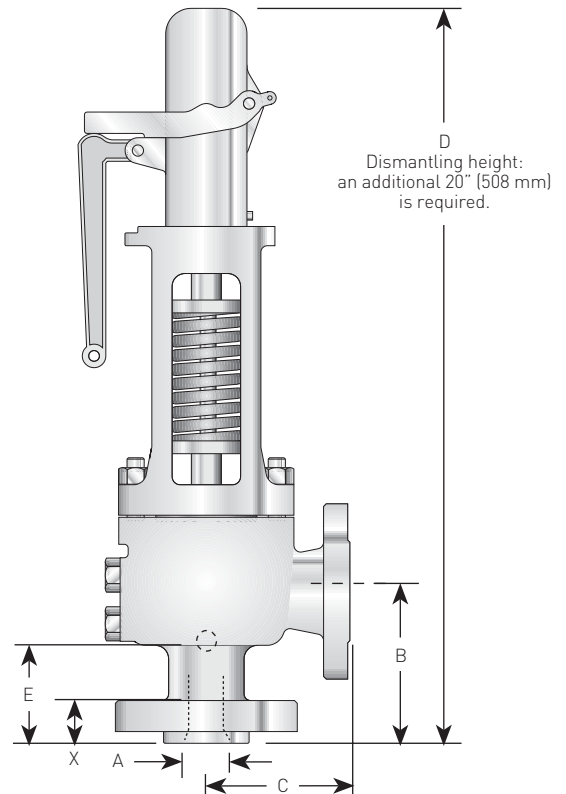

CROSBY H-SERIES

STYLE HSL

STYLE HSL - PRESSURE AND TEMPERATURE LIMITS

CL 300 - ANSI RAISED FACE FLANGE

Valve size inlet orifice outlet	Orifice area square inch (mm)	Maximum set pressure			Style designation - standard body mat. and max. temp.		Standard flanged outlet Class
		at 900°F (482°C) or less psig (barg)	at 950°F (510°C) psig (barg)	at 1000°F (538°C) psig (barg)	SA216 Gr. WCB 750°F (399°C)	SA217 Gr. WC6 1000°F (538°C)	
1¼ F 1½	0.339 [218.7]	330 [22.76]	320 [22.07]	215 [14.83]	HSL-36	HSL-38	150
1¼ G 1½	0.553 [356.8]	330 [22.76]	320 [22.07]	215 [14.83]	HSL-36	HSL-38	150
1½ H 2½	0.868 [600.0]	330 [22.76]	320 [22.07]	215 [14.83]	HSL-36	HSL-38	150
1½ J 2½	1.327 [856.1]	330 [22.76]	320 [22.07]	215 [14.83]	HSL-36	HSL-38	150
2 K 3	2.046 [1320.0]	330 [22.76]	320 [22.07]	215 [14.83]	HSL-36	HSL-38	150
2½ L 4	3.167 [2043.2]	330 [22.76]	320 [22.07]	215 [14.83]	HSL-36	HSL-38	150
3 M 4	3.955 [2551.6]	330 [22.76]	320 [22.07]	215 [14.83]	HSL-36	HSL-38	150
4 N 6	4.831 [3116.8]	330 [22.76]	320 [22.07]	215 [14.83]	HSL-36	HSL-38	150
4 P 6	7.031 [4536.1]	330 [22.76]	320 [22.07]	215 [14.83]	HSL-36	HSL-38	150
6 QQ 8	11.045 [7125.8]	330 [22.76]	320 [22.07]	215 [14.83]	HSL-36	HSL-38	150

CL 600 - ANSI RAISED FACE FLANGE

Valve size inlet orifice outlet	Orifice area square inch (mm)	Maximum set pressure			Style designation - standard body mat. and max. temp.		Standard flanged outlet Class
		at 900°F (482°C) or less psig (barg)	at 950°F (510°C) psig (barg)	at 1000°F (538°C) psig (barg)	SA216 Gr. WCB 750°F (399°C)	SA217 Gr. WC6 1000°F (538°C)	
1¼ F 1½	0.339 [218.7]	725 [50]	640 [44.14]	430 [29.66]	HSL-46	HSL-48	150
1¼ G 1½	0.553 [356.8]	725 [50]	640 [44.14]	430 [29.66]	HSL-46	HSL-48	150
1½ H 2½	0.868 [600.0]	725 [50]	640 [44.14]	430 [29.66]	HSL-46	HSL-48	150
1½ J 2½	1.327 [856.1]	725 [50]	640 [44.14]	430 [29.66]	HSL-46	HSL-48	150
2 K 3	2.046 [1320.0]	725 [50]	640 [44.14]	430 [29.66]	HSL-46	HSL-48	150
2½ L 4	3.167 [2043.2]	725 [50]	640 [44.14]	430 [29.66]	HSL-46	HSL-48	150
3 M 4	3.955 [2551.6]	725 [50]	640 [44.14]	430 [29.66]	HSL-46	HSL-48	150
4 N 6	4.831 [3116.8]	725 [50]	640 [44.14]	430 [29.66]	HSL-46	HSL-48	150
4 P 6	7.031 [4536.1]	725 [50]	640 [44.14]	430 [29.66]	HSL-46	HSL-48	150
6 QQ 8	11.045 [7125.8]	725 [50]	640 [44.14]	430 [29.66]	HSL-46	HSL-48	150

NOTE

Set pressure is limited to either the inlet pressure limit per ASME B16.34 or the maximum set pressure listed in the tables above, whichever is lower.

CROSBY H-SERIES

STYLE HCA-I-118W ISOFLEX SUPERCRITICAL SERVICE

STYLE HCA-I-118W

Style HCA-I-118W are high capacity reaction type safety valves specially designed to withstand the severe operating conditions on supercritical pressure steam generators.

FEATURES

- Increases Operating Efficiency
 - Restricted lift option for customized capacity, reduced reaction forces and boiler design standardization.
 - Seat tightness up to 93%. For seat tightness greater than 93% consult factory.
 - Two ring control to adjust overpressure and blowdown independently.
 - May also be used for ASME VIII off boiler steam applications for higher operating pressures.
- Reduces Maintenance Costs
 - Interchangeable spare parts minimizes inventory levels.
 - Higher nozzle seat step to extend valve service life.
- Minimizes Installation Costs
 - Packaging designed for quick and easy installation.
 - Easy to set and adjust set pressure while in service.

Certification and type Approvals

- ASME Boiler and Pressure Vessel Code, Section I
- National Board of Boiler and Pressure Vessel Inspectors Capacity Certifications
- Pressure Equipment Directive (97/27/EC) (ISO 4126-1) (CE)
- China Manufacturing License (TS)

TECHNICAL DATA

Inlet sizes:	2½" and 3"
Inlet rating:	CL 4500# butt weld
Outlet rating:	CL 300#
Maximum set pressures:	6200 psig [427 barg]
Temperature range:	to 1100°F [593°C]
Four (4) orifices:	K, K2, M and M2
Blowdown:	4%



CROSBY H-SERIES

STYLE HCA-I

STYLE HCA-I-118W ISOFLEX MATERIALS

Part ref. No.	Part name	Material and Maximum Temperature	
		Style HCA-I-118W-C 1050°F (566°C)	Style HCA-1-18W-C12A-C 1120°F (604°C)
1A	Body	ASME SA217 Grade WC9	ASME SA217 Grade C12A
1B	Nozzle	ASME SB564 N06625	ASME SB564 N06625
3	Nozzle ring	316 Stainless steel	316 Stainless steel
4	Nozzle ring set screw	416 Stainless steel	416 Stainless steel
5	Disc insert	ASME SB637 UNS N07718	ASME SB637 UNS N07718
6	Disc holder	NI-CU Alloy	NI-CU Alloy
7	Disc holder retainer	Stainless steel	Stainless steel
8	Disc holder retainer cotter	Stainless steel	Stainless steel
9	Guide	NI-CU Alloy	NI-CU Alloy
10	Guide ring	316 Stainless steel	316 Stainless steel
11	Guide ring set screw	416 Stainless steel	416 Stainless steel
12A	Spindle point	ASTM A565 GR 616 COND. HT	ASTM A565 GR 616 COND. HT
12B	Spindle rod	Stainless steel	Stainless steel
12C	Spindle rod pin	Stainless steel	Stainless steel
13	Cooling spool	ASME SA217 Grade WC9	ASME SA217 Grade WC9
14	Cooling spool studs	ASTM A193 B16	ASTM A193 B16
15	Cooling spool stud nut	ASME SA194 GR 2H	ASME SA194 GR 2H
16	Bonnet	ASME SA217 Grade WC9	ASME SA217 Grade WC9
17	Bonnet studs	Alloy Steel SA-193 Gr. B16	Alloy Steel SA-193 Gr. B16
18	Bonnet stud nuts	ASME SA194 GR 2H	ASME SA194 GR 2H
19	Spring	A681-H12 (Cor. Res. Coating)	A681-H12 (Cor. Res. Coating)
20	Bottom spring washer	Steel	Steel
21A	Top spring washer	Steel	Steel
21B	Locking rod	Steel	Steel
21C	Pin	Steel	Steel
22	Thrust bearing	Bronze	Bronze
23	Bearing adapter	Alloy Steel	Alloy Steel
24	Adjusting bolt	ASTM A582 TP 416 COND. T	ASTM A582 TP 416 COND. T
25	Adjusting bolt nut	Stainless steel	Stainless steel
26	Spindle nut	416 Steel	416 Steel
27	Spindle nut cotter	Stainless steel	Stainless steel
28	Cap	Malleable iron	Malleable iron
29	Cap set screw	High grade alloy steel	High grade alloy steel
30	Lever	Malleable iron	Malleable iron
31	Lever pin	Steel	Steel
32	Lever pin cotter	Steel	Steel
33	Forked lever	Malleable iron	Malleable iron
34	Forked lever pin	Steel	Steel
35	Forked lever pin cotter	Steel	Steel
36	Seal and wire	Stainless steel	Stainless steel
37	Nameplate	Stainless steel	Stainless steel
38	Drive screw	Stainless steel	Stainless steel
39	Drain plug	Steel	Steel
40	Test clamp ^[1]	Steel	Steel
41	Gag screw ^[1]	Stainless steel	Stainless steel
42	Hydrostatic cap ^[1]	Stainless steel	Stainless steel
43	Hydrostatic plug ^[1]	Stainless steel	Stainless steel
44	Hydrostatic plug pin ^[1]	Stainless steel	Stainless steel
45	O-ring ^[1]	Ethylene Propylene	Ethylene Propylene
46	Back-up ring ^[1]	BUNA-N	BUNA-N

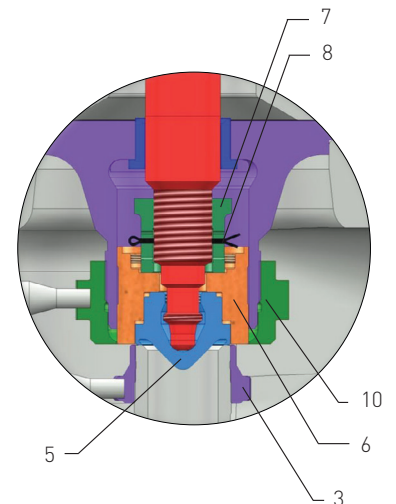
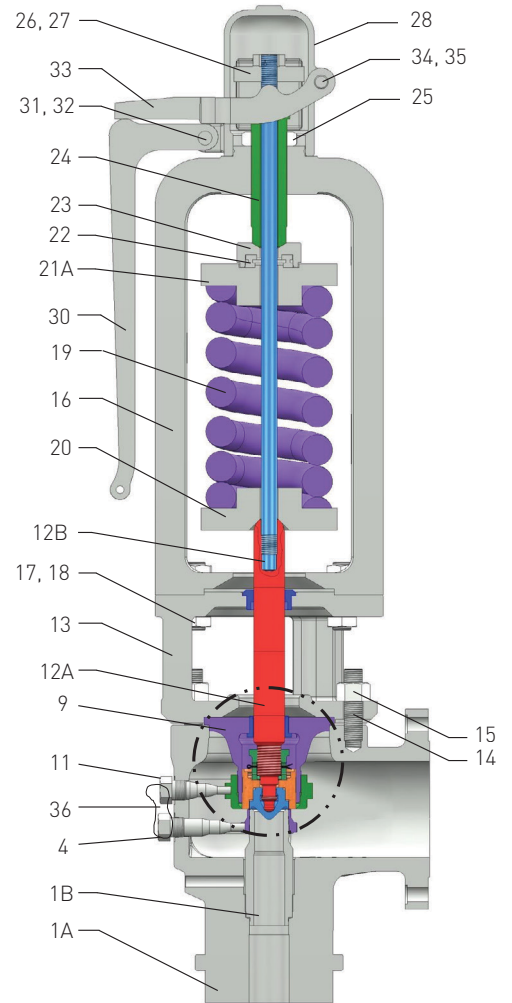

NOTES

1. Not shown in illustrations.

CROSBY H-SERIES

STYLE HCA-I

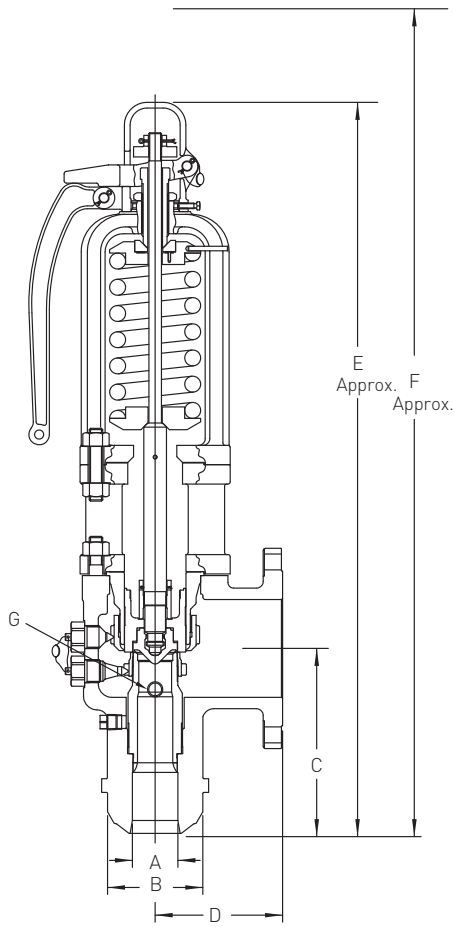

HCA-I DIMENSIONS AND WEIGHTS

Standard Connections			Dimensions - inches (mm)									
Valve size	Orifice	Butt weld	Flanged	'A'	'B'	'C'	'D'	'E'	'F'	'G'	Approx. Weight	
Inlet x Orifice	letter designat.	inlet	outlet size (in.) and ANSI Class	Inlet I.D. in. (mm)	Max. inlet O.D. in. (mm)	Center to face of Inlet of Outlet in. (mm)		Approx. in. (mm)	Dismantling height in. (mm)	Drain (NPT)		
2.5 x K x 6	K	1.840 [1186]	2½ [63.5]	6" Cl 300#	2½ [63.5]	8 [203]	12 [305]	10 [254]	60 [1524]	80 [2032]	½	660 [299]
2.5 x K2 x 6	K2	2.545 [1642]	2½ [63.5]	6" Cl 300#	2½ [63.5]	8 [203]	12 [305]	10 [254]	60 [1524]	80 [2032]	½	680 [308]
3 x M x 8	M	3.600 [2323]	3 [76.2]	8" Cl 300#	3 [76.2]	9¼ [235]	13 [330]	10½ [267]	62 [1575]	82 [2082]	½	900 [408]
3 x M2 x 8	M2	3.976 [2565]	3 [76.2]	8" Cl 300#	3 [76.2]	9¼ [235]	13 [330]	10½ [267]	62 [1575]	82 [2082]	½	930 [422]

HCA-I PRESSURE AND TEMPERATURE LIMITS

Body Material			SA217-WC9							Standard Flanged Outlet Class
Valve Size	Orifice	Inlet Type	Maximum Set Pressure psig (barg)							
Inlet x Orifice	Area Sq. In. (Sq. mm.)		Temperature							
x Outlet			750°F [399°C]	800°F [426°C]	850°F [454°C]	900°F [482°C]	950°F [510°C]	1000°F [538°C]	1050°F [566°C]	
2.5 x K x 6	1.840 [1186]	*	4200 [290]	5350 [368]	5300 [365]	5250 [362]	5200 [358]	5150 [355]	5050 [348]	6 CL. 300
2.5 x K2 x 6	2.545 [1642]	*	4200 [290]	5550 [382]	5500 [379]	5450 [375]	5400 [372]	5350 [368]	5250 [362]	6 CL. 300
3 x M x 8	3.600 [2323]	*	4200 [290]	6150 [424]	6200 [427]	6200 [427]	6200 [427]	6200 [427]	5300 [365]	8 CL. 300
3 x M2 x 8	3.976 [2565]	*	4200 [290]	6150 [424]	6200 [427]	6200 [427]	6200 [427]	5840 [403]	3800 [262]	8 CL. 300

Body Material			SA217-C12A								Standard Flanged Outlet Class
Valve Size	Orifice	Inlet Type	Maximum Set Pressure psig (barg)								
Inlet x Orifice	Area Sq. In. (Sq. mm.)		Temperature								
x Outlet			750°F [399°C]	800°F [426°C]	850°F [454°C]	900°F [482°C]	950°F [510°C]	1000°F [538°C]	1050°F [566°C]	1100°F [593°C]	
2.5 x K x 6	1.840 [1186]	*	4200 [290]	5350 [368]	5300 [365]	5250 [362]	5200 [358]	5150 [355]	5050 [348]	5000 [344]	6 CL. 300
2.5 x K2 x 6	2.545 [1642]	*	4200 [290]	5550 [382]	5500 [379]	5450 [375]	5400 [372]	5350 [368]	5250 [362]	5150 [355]	6 CL. 300
3 x M x 8	3.600 [2323]	*	4200 [290]	6150 [424]	6200 [427]	6200 [427]	6200 [427]	6200 [427]	6200 [427]	6200 [427]	8 CL. 300
3 x M2 x 8	3.976 [2565]	*	4200 [290]	6150 [424]	6200 [427]	6200 [427]	6200 [427]	6200 [427]	6200 [427]	6200 [427]	8 CL. 300

* Butt weld

CROSBY H-SERIES

SATURATED STEAM CAPACITIES

STYLES HE, HCI AND HSJ - USCS (UNITED STATES CUSTOMARY SYSTEM) UNITS - SATURATED STEAM CAPACITIES*

Pounds per hour at 3% overpressure

SATURATED STEAM CAPACITIES - SET PRESSURES 15-550 psig

		Orifice designation and area (sq. in.)																	
HE																			
HCI																			
HSJ																			
Set	Orifice (sq. in.)																		
pres. (psig)	F	G	H	H2	J	J2	K	K2	L	L2	M	M2	N	P	P2	Q	Q2	R	RR
	0.307	0.503	0.785	0.994	1.288	1.431	1.840	2.545	2.853	3.341	3.600	3.976	4.341	6.380	7.070	11.045	12.250	16.000	19.290
15	440	720	1125	-	1846	-	2637	-	4089	-	5160	-	6222	9144	-	15831	-	-	-
20	509	834	1302	-	2137	-	3053	-	4734	-	5974	-	7203	10587	-	18328	-	-	-
30	648	1062	1657	-	2719	-	3885	-	6024	-	7601	-	9166	13472	-	23322	-	-	-
40	787	1289	2012	-	3302	-	4717	-	7314	-	9229	-	11129	16357	-	28317	-	-	-
50	925	1517	2367	-	3884	-	5549	-	8604	-	10857	-	13092	19241	-	33311	-	-	-
60	1064	1744	2722	-	4466	-	6381	-	9894	-	12485	-	15055	22126	-	38305	-	-	-
70	1204	1974	3080	-	5055	-	7221	-	11197	-	14129	-	17037	25040	-	43349	-	-	-
80	1347	2208	3446	-	5655	-	8078	-	12526	-	15806	-	19059	28011	-	48493	-	-	-
90	1490	2442	3812	-	6254	-	8935	-	13855	-	17482	-	21081	30983	-	53637	-	-	-
100	1633	2676	4177	-	6854	-	9792	-	15183	-	19159	-	23102	33954	-	58781	-	-	-
110	1776	2911	4543	-	7454	-	10649	-	16512	-	20835	-	25124	36926	-	63925	-	-	-
120	1919	3145	4909	-	8054	-	11506	-	17841	-	22512	-	27146	39897	-	69070	-	-	-
130	2062	3379	5274	-	8654	-	12363	-	19170	-	24189	-	29168	42868	-	74214	-	-	-
140	2205	3614	5640	-	9254	-	13220	-	20498	-	25865	-	31190	45840	-	79358	-	-	-
150	2348	3848	6005	-	9854	-	14077	-	21827	-	27542	-	33211	48811	-	84502	-	-	-
160	2491	4082	6371	-	10453	-	14934	-	23156	-	29219	-	35233	51782	-	89646	-	-	-
170	2634	4316	6737	-	11053	-	15791	-	24484	-	30895	-	37255	54754	-	94790	-	-	-
180	2777	4551	7102	-	11653	-	16648	-	25813	-	32572	-	39277	57725	-	99934	-	-	-
190	2920	4785	7468	-	12253	-	17505	-	27142	-	34249	-	41298	60697	-	105078	-	-	-
200	3063	5019	7833	-	12853	-	18362	-	28471	-	35925	-	43320	63668	-	110222	-	-	-
210	3206	5253	8199	-	13453	-	19219	-	29799	-	37602	-	45342	66639	-	115366	-	-	-
220	3349	5488	8565	-	14053	-	20075	-	31128	-	39279	-	47364	69611	-	120510	-	-	-
230	3492	5722	8930	-	14653	-	20932	-	32457	-	40955	-	49385	72582	-	125654	-	-	-
240	3635	5956	9296	-	15252	-	21789	-	33786	-	42632	-	51407	75554	-	130798	-	-	-
250	3778	6190	9661	-	15852	-	22646	-	35114	-	44309	-	53429	78525	-	135942	-	-	-
260	3921	6425	10027	-	16452	-	23503	-	36443	-	45985	-	55451	81496	-	141086	-	-	-
270	4064	6659	10393	-	17052	-	24360	-	37772	-	47662	-	57472	84468	-	146230	-	-	-
280	4207	6893	10758	-	17652	-	25217	-	39101	-	49338	-	59494	87439	-	151374	-	-	-
290	4350	7128	11124	-	18252	-	26074	-	40429	-	51015	-	61516	90411	-	156518	-	-	-

* Refer to capacity formula, page 52.

Capacities certified by the national board of boiler and pressure vessel inspectors in accordance with the ASME boiler and pressure vessel code. Section I, power boilers.

For superheated steam, multiply the saturated steam capacities by superheat correction factor K_{sh} , pages 62-63. Capacities for the HCI-R valves: valves adjust to a minimum of 30% of full rated capacity. Restricted capacity = (% of restricted lift) x ASME rated capacity.

CROSBY H-SERIES

SATURATED STEAM CAPACITIES

STYLES HE, HCI AND HSJ - USCS (UNITED STATES CUSTOMARY SYSTEM) UNITS - SATURATED STEAM CAPACITIES*

Pounds per hour at 3% overpressure

SATURATED STEAM CAPACITIES - SET PRESSURES 15-550 psig (continued)

HE HCI HSJ Set pres. psig	Orifice designation and area (sq. in.)																		
	F	G	H	H2	J	J2	K	K2	L	L2	M	M2	N	P	P2	Q	Q2	R	RR
	0.307	0.503	0.785	0.994	1.288	1.431	1.840	2.545	2.853	3.341	3.600	3.976	4.341	6.380	7.070	11.045	12.250	16.000	19.290
300	4493	7362	11489	14548	18852	20945	26931	37250	41758	48901	52692	58195	63538	93382	103481	161662	179300	234187	282342
310	4636	7596	11855	15011	19451	21611	27788	38435	43087	50457	54368	60047	65559	96353	106774	166806	185005	241639	291326
320	4779	7830	12221	15474	20051	22278	28645	39621	44416	52013	56045	61899	67581	99325	110067	171950	190710	249091	300310
330	4922	8065	12586	15937	20651	22944	29502	40806	45744	53569	57722	63750	69603	102296	113360	177094	196415	256543	309294
340	5065	8299	12952	16400	21251	23611	30359	41991	47073	55125	59398	65602	71625	105267	116652	182239	202121	263994	318278
350	5208	8533	13317	16863	21851	24277	31216	43176	48402	56681	61075	67454	73646	108239	119945	187383	207826	271446	327262
360	5351	8767	13683	17326	22451	24943	32073	44362	49731	58237	62752	69306	75668	111210	123238	192527	213531	278898	336246
370	5494	9002	14049	17789	23051	25610	32930	45547	51059	59793	64428	71158	77690	114182	126531	197671	219236	286350	345230
380	5637	9236	14414	18252	23651	26276	33787	46732	52388	61349	66105	73009	79712	117153	129823	202815	224942	293801	354215
390	5780	9470	14780	18715	24250	26943	34644	47918	53717	62905	67782	74861	81733	120124	133116	207959	230647	301253	363199
400	5923	9704	15145	19178	24850	27609	35501	49103	55046	64461	69458	76713	83755	123096	136409	213103	236352	308705	372183
410	6066	9939	15511	19641	25450	28276	36358	50288	56374	66017	71135	78565	85777	126067	139701	218247	242057	316157	381167
420	6209	10173	15877	20104	26050	28942	37215	51474	57703	67573	72812	80416	87799	129039	142994	223391	247763	323609	390151
430	6352	10407	16242	20567	26650	29609	38071	52659	59032	69129	74488	82268	89820	132010	146287	228535	253468	331060	399135
440	6495	10641	16608	21030	27250	30275	38928	53844	60361	70685	76165	84120	91842	134981	149580	233679	259173	338512	408119
450	6638	10876	16973	21493	27850	30942	39785	55029	61689	72241	77841	85972	93864	137953	152872	238823	264878	345964	417103
460	6781	11110	17339	21955	28449	31608	40642	56215	63018	73797	79518	87823	95886	140924	156165	243967	270584	353416	426087
470	6924	11344	17705	22418	29049	32275	41499	57400	64347	75353	81195	89675	97907	143896	159458	249111	276289	360867	435071
480	7067	11579	18070	22881	29649	32941	42356	58585	65675	76909	82871	91527	99929	146867	162751	254255	281994	368319	444055
490	7210	11813	18436	23344	30249	33608	43213	59771	67004	78465	84548	93379	101951	149838	166043	259399	287699	375771	453039
500	7353	12047	18801	23807	30849	34274	44070	60956	68333	80021	86225	95230	103973	152810	169336	264543	293405	383223	462023
510	7496	12281	19167	24270	31449	34940	44927	62141	69662	81577	87901	97082	105994	155781	172629	269687	299110	390674	471007
520	7639	12516	19533	24733	32049	35607	45784	63327	70990	83133	89578	98934	108016	158752	175922	274831	304815	398126	479991
530	7782	12750	19898	25196	32649	36273	46641	64512	72319	84689	91255	100786	110038	161724	179214	279975	310520	405578	488975
540	7925	12984	20264	25659	33248	36940	47498	65697	73648	86245	92931	102637	112060	164695	182507	285119	316226	413030	497959
550	8067	13218	20629	26122	33848	37606	48355	66882	74977	87801	94608	104489	114082	167667	185800	290263	321931	420481	506943

* Refer to capacity formula, page 52.

Capacities certified by the national board of boiler and pressure vessel inspectors in accordance with the ASME boiler and pressure vessel code. Section I, power boilers.

For superheated steam, multiply the saturated steam capacities by superheat correction factor K_{sh} , pages 62-63. Capacities for the HCI-R valves: valves adjust to a minimum of 30% of full rated capacity. Restricted capacity = (% of restricted lift) x ASME rated capacity.

CROSBY H-SERIES

SATURATED STEAM CAPACITIES

STYLES HE, HCI AND HSJ - USCS (UNITED STATES CUSTOMARY SYSTEM) UNITS - SATURATED STEAM CAPACITIES*

Pounds per hour at 3% overpressure

SATURATED STEAM CAPACITIES - SET PRESSURES 560-1100 psig

HE HCI HSJ Set pres. psig	Orifice designation and area (sq. in.)																		
	F 0.307	G 0.503	H 0.785	H2 0.994	J 1.288	J2 1.431	K 1.840	K2 2.545	L 2.853	L2 3.341	M 3.600	M2 3.976	N 4.341	P 6.380	P2 7.070	Q 11.045	Q2 12.250	R 16.000	RR 19.290
560	8210	13453	20995	26585	34448	38273	49212	68068	76305	89357	96285	106341	116103	170638	189093	295407	327636	427933	515927
570	8353	13687	21361	27048	35048	38939	50069	69253	77634	90913	97961	108193	118125	173609	192385	300552	333341	435385	524911
580	8496	13921	21726	27511	35648	39606	50926	70438	78963	92469	99638	110045	120147	176581	195678	305696	339047	442837	533895
590	8639	14155	22092	27974	36248	40272	51783	71624	80292	94025	101315	111896	122169	179552	198971	310840	344752	450288	542879
600	8782	14390	22457	28437	36848	40939	52640	72809	81620	95581	102991	113748	124190	182524	202264	315984	350457	457740	551863
610	8925	14624	22823	28900	37447	41605	53497	73994	82949	97138	104668	115600	126212	185495	205556	-	356163	465192	560847
620	9068	14858	23189	29363	38047	42272	54354	75179	84278	98694	106344	117452	128234	188466	208849	-	361868	472644	569831
630	9211	15093	23554	29825	38647	42938	55211	76365	85607	100250	108021	119303	130256	191438	212142	-	367573	480096	578815
640	9354	15327	23920	30288	39247	43605	56067	77550	86935	101806	109698	121155	132277	194409	215435	-	373278	487547	587799
650	9497	15561	24285	30751	39847	44271	56924	78735	88264	103362	111374	123007	134299	197381	218727	-	378984	494999	596783
660	9640	15795	24651	31214	40447	44937	57781	79921	89593	104918	113051	124859	136321	200352	222020	-	384689	502451	605767
670	9783	16030	25017	31677	41047	45604	58638	81106	90922	106474	114728	126710	138343	203323	225313	-	390394	509903	614751
680	9926	16264	25382	32140	41647	46270	59495	82291	92250	108030	116404	128562	140364	206295	228606	-	396099	517354	623735
690	10069	16498	25748	32603	42246	46937	60352	83477	93579	109586	118081	130414	142386	209266	231898	-	401805	524806	632719
700	10212	16732	26113	33066	42846	47603	61209	84662	94908	111142	119758	132266	144408	212238	235191	-	407510	532258	641703
710	10355	16967	26479	33529	43446	48270	62066	85847	96237	112698	121434	134117	146430	215209	238484	-	413215	539710	650688
720	10498	17201	26845	33992	44046	48936	62923	87032	97565	114254	123111	135969	148451	218180	241777	-	418920	547161	659672
730	10641	17435	27210	34455	44646	49603	63780	88218	98894	115810	124788	137821	150473	221152	245069	-	424626	554613	668656
740	10784	17669	27576	34918	45246	50269	64637	89403	100223	117366	126464	139673	152495	224123	248362	-	430331	562065	677640
750	10927	17904	27941	35381	45846	50936	65494	90588	101552	118922	128141	141525	154517	227094	251655	-	436036	569517	686624
760	11070	18138	28307	35844	46445	51602	66351	91774	102880	120478	129818	143376	156538	230066	254948	-	441741	576968	695608
770	11213	18372	28673	36307	47045	52269	67208	92959	104209	122034	131494	145228	158560	233037	258240	-	447447	584420	704592
780	11356	18606	29038	36770	47645	52935	68065	94144	105538	123590	133171	147080	160582	236009	261533	-	453152	591872	713576
790	11499	18841	29404	37233	48245	53602	68922	95330	106866	125146	134847	148932	162604	238980	264826	-	458857	599324	722560
800	11642	19075	29769	37695	48845	54268	69779	96515	108195	126702	136524	150783	164625	241951	268119	-	464562	606775	731544
810	11785	19309	30135	38158	49445	54934	70636	97700	109524	128258	138201	152635	166647	244923	271411	-	470268	614227	740528
820	11928	19544	30501	38621	50045	55601	71493	98885	110853	129814	139877	154487	168669	247894	274704	-	475973	621679	749512
830	12071	19778	30866	39084	50645	56267	72350	100071	112181	131370	141554	156339	170691	250866	277997	-	481678	629131	758496
840	12214	20012	31232	39547	51244	56934	73207	101256	113510	132926	143231	158190	172712	253837	281290	-	487383	636583	767480
850	12357	20246	31597	40010	51844	57600	74063	102441	114839	134482	144907	160042	174734	256808	284582	-	493089	644034	776464
860	12500	20481	31963	40473	52444	58267	74920	103627	116168	136038	146584	161894	176756	259780	287875	-	498794	651486	785448
870	12643	20715	32329	40936	53044	58933	75777	104812	117496	137594	148261	163746	178778	262751	291168	-	504499	658938	794432
880	12786	20949	32694	41399	53644	59600	76634	105997	118825	139150	149937	165597	180799	265723	294461	-	510204	666390	803416
890	12929	21183	33060	41862	54244	60266	77491	107182	120154	140706	151614	167449	182821	268694	297753	-	515910	673841	812400
900	13072	21418	33425	42325	54844	60933	78348	108368	121483	142262	153291	169301	184843	271665	301046	-	521615	681293	821384

* Refer to capacity formula, page 52.

Capacities certified by the national board of boiler and pressure vessel inspectors in accordance with the ASME boiler and pressure vessel code. Section I, power boilers.

For superheated steam, multiply the saturated steam capacities by superheat correction factor K_{sh} , pages 62-63. Capacities for the HCI-R valves: valves adjust to a minimum of 30% of full rated capacity. Restricted capacity = [% of restricted lift] x ASME rated capacity.

CROSBY H-SERIES

SATURATED STEAM CAPACITIES

STYLES HE, HCI AND HSJ - USCS (UNITED STATES CUSTOMARY SYSTEM) UNITS - SATURATED STEAM CAPACITIES*

Pounds per hour at 3% overpressure

SATURATED STEAM CAPACITIES - SET PRESSURES 560-1100 psig (continued)

		Orifice designation and area (sq. in.)																	
HE																			
HCI																			
HSJ																			
Set	Orifice (sq. in.)																		
pres.	F	G	H	H2	J	J2	K	K2	L	L2	M	M2	N	P	P2	Q	Q2	R	RR
psig	0.307	0.503	0.785	0.994	1.288	1.431	1.840	2.545	2.853	3.341	3.600	3.976	4.341	6.380	7.070	11.045	12.250	16.000	19.290
910	13215	21652	33791	42788	55444	61599	79205	109553	-	143818	-	171153	-	-	304339	-	527320	688745	830368
920	13358	21886	34157	43251	56043	62266	80062	110738	-	145374	-	173004	-	-	307632	-	533025	696197	839352
930	13501	22120	34522	43714	56643	62932	80919	111924	-	146930	-	174856	-	-	310924	-	538731	703648	848336
940	13644	22355	34888	44177	57243	63599	81776	113109	-	148486	-	176708	-	-	314217	-	544436	711100	857320
950	13787	22589	35253	44640	57843	64265	82633	114294	-	150042	-	178560	-	-	317510	-	550141	718552	866304
960	13930	22823	35619	45103	58443	64931	83490	115480	-	151598	-	180412	-	-	320803	-	555846	726004	875288
970	14073	23058	35985	45565	59043	65598	84347	116665	-	153154	-	182263	-	-	324095	-	561552	733455	884272
980	14216	23292	36350	46028	59643	66264	85204	117850	-	154710	-	184115	-	-	327388	-	567257	740907	893256
990	14359	23526	36716	46491	60242	66931	86061	119035	-	156266	-	185967	-	-	330681	-	572962	748359	902240
1000	14502	23760	37081	46954	60842	67597	86918	120221	-	157822	-	187819	-	-	333974	-	578667	755811	911224
1010	14645	23995	37447	47417	61442	68264	87775	121406	-	159378	-	189670	-	-	337266	-	584373	763262	920208
1020	14788	24229	37813	47880	62042	68930	88632	122591	-	160934	-	191522	-	-	340559	-	590078	770714	929192
1030	14931	24463	38178	48343	62642	69597	89489	123777	-	162490	-	193374	-	-	343852	-	595783	778166	938176
1040	15074	24697	38544	48806	63242	70263	90346	124962	-	164046	-	195226	-	-	347145	-	601488	785618	947160
1050	15217	24932	38909	49269	63842	70930	91203	126147	-	165602	-	197077	-	-	350437	-	607194	793070	956145
1060	15360	25166	39275	49732	64442	71596	92060	127332	-	167158	-	198929	-	-	353730	-	612899	800521	965129
1070	15502	25400	39641	50195	65041	72263	92916	128518	-	168714	-	200781	-	-	357023	-	618604	807973	974113
1080	15645	25634	40006	50658	65641	72929	93773	129703	-	170270	-	202633	-	-	360316	-	624309	815425	983097
1090	15788	25869	40372	51121	66241	73596	94630	130888	-	171827	-	204484	-	-	363608	-	630015	822877	992081
1100	15931	26103	40738	51584	66841	74262	95487	132074	-	173383	-	206336	-	-	366901	-	635720	830328	1001065

* Refer to capacity formula, page 52.

Capacities certified by the national board of boiler and pressure vessel inspectors in accordance with the ASME boiler and pressure vessel code. Section I, power boilers.

For superheated steam, multiply the saturated steam capacities by superheat correction factor K_{sh} , pages 62-63. Capacities for the HCI-R valves: valves adjust to a minimum of 30% of full rated capacity. Restricted capacity = [% of restricted lift] x ASME rated capacity.

CROSBY H-SERIES

SATURATED STEAM CAPACITIES

STYLES HE, HCI AND HSJ - USCS (UNITED STATES CUSTOMARY SYSTEM) UNITS - SATURATED STEAM CAPACITIES*

Pounds per hour at 3% overpressure

SATURATED STEAM CAPACITIES - SET PRESSURES 1100-1650 psig

HE HCI HSJ Set	Orifice designation and area (sq. in.)																		
	Orifice (sq. in.)																		
pres. psig	F	G	H	H2	J	J2	K	K2	L	L2	M	M2	N	P	P2	Q	Q2	R	RR
	0.307	0.503	0.785	0.994	1.288	1.431	1.840	2.545	2.853	3.341	3.600	3.976	4.341	6.380	7.070	11.045	12.250	16.000	19.290
1110	16074	26337	41103	52047	67441	74929	96344	133259	-	174939	-	208188	-	-	370194	-	641425	837780	1010049
1120	16217	26571	41469	52510	68041	75595	97201	134444	-	176495	-	210040	-	-	373487	-	647131	845232	1019033
1130	16360	26806	41834	52972	68641	76261	98058	135630	-	178051	-	211891	-	-	376779	-	652836	852684	1028017
1140	16503	27040	42200	53435	69240	76928	98915	136815	-	179607	-	213743	-	-	380072	-	658541	860135	1037001
1150	16646	27274	42566	53898	69840	77594	99772	138000	-	181163	-	215595	-	-	383365	-	664246	867587	1045985
1160	16789	27509	42931	54361	70440	78261	100629	139185	-	182719	-	217447	-	-	386658	-	669952	875039	1054969
1170	16932	27743	43297	54824	71040	78927	101486	140371	-	184275	-	219299	-	-	389950	-	675657	882491	1063953
1180	17075	27977	43662	55287	71640	79594	102343	141556	-	185831	-	221150	-	-	393243	-	681362	889942	1072937
1190	17218	28211	44028	55750	72240	80260	103200	142741	-	187387	-	223002	-	-	396536	-	687067	897394	1081921
1200	17361	28446	44394	56213	72840	80927	104057	143927	-	188943	-	224854	-	-	399829	-	692773	904846	1090905
1210	17504	28680	44759	56676	73440	81593	104914	145112	-	190499	-	226706	-	-	403121	-	698478	912298	1099889
1220	17647	28914	45125	57139	74039	82260	105771	146297	-	192055	-	228557	-	-	406414	-	704183	919749	1108873
1230	17790	29148	45490	57602	74639	82926	106628	147483	-	193611	-	230409	-	-	409707	-	709888	927201	1117857
1240	17933	29383	45856	58065	75239	83593	107485	148668	-	195167	-	232261	-	-	413000	-	715594	934653	1126841
1250	18076	29617	46222	58528	75839	84259	108342	149853	-	196723	-	234113	-	-	416292	-	721299	942105	1135825
1260	18219	29851	46587	58991	76439	84926	109199	151038	-	198279	-	235964	-	-	419585	-	727004	949557	1144809
1270	18362	30085	46953	59454	77039	85592	110056	152224	-	199835	-	237816	-	-	422878	-	732709	957008	1153793
1280	18505	30320	47318	59917	77639	86258	110912	153409	-	201391	-	239668	-	-	426170	-	738415	964460	1162777
1290	18648	30554	47684	60380	78238	86925	111769	154594	-	202947	-	241520	-	-	429463	-	744120	971912	1171761
1300	18791	30788	48050	60842	78838	87591	112626	155780	-	204503	-	243371	-	-	432756	-	749825	979364	1180745
1310	18934	31023	48415	61305	79438	88258	113483	156965	-	206059	-	245223	-	-	436049	-	755530	986815	1189729
1320	19077	31257	48781	61768	80038	88924	114340	158150	-	207615	-	247075	-	-	439341	-	761236	994267	1198713
1330	19220	31491	49146	62231	80638	89591	115197	159335	-	209171	-	248927	-	-	442634	-	766941	1001719	1207697
1340	19363	31725	49512	62694	81238	90257	116054	160521	-	210727	-	250779	-	-	445927	-	772646	1009171	1216681
1350	19506	31960	49878	63157	81838	90924	116911	161706	-	212283	-	252630	-	-	449220	-	778351	1016622	1225665
1360	19649	32194	50243	63620	82438	91590	117768	162891	-	213839	-	254482	-	-	452512	-	784057	1024074	1234649
1370	19792	32428	50609	64083	83037	92257	118625	164077	-	215395	-	256334	-	-	455805	-	789762	1031526	1243633
1380	19935	32662	50974	64546	83637	92923	119482	165262	-	216951	-	258186	-	-	459098	-	795467	1038978	1252618
1390	20078	32897	51340	65009	84237	93590	120339	166447	-	218507	-	260037	-	-	462391	-	801172	1046429	1261602
1400	20221	33131	51706	65472	84837	94256	121196	167633	-	220063	-	261889	-	-	465683	-	806878	1053881	1270586

* Refer to capacity formula, page 52.

Capacities certified by the national board of boiler and pressure vessel inspectors in accordance with the ASME boiler and pressure vessel code. Section I, power boilers.

For superheated steam, multiply the saturated steam capacities by superheat correction factor K_{sh} , page 62-63. Capacities for the HCI-R valves: valves adjust to a minimum of 30% of full rated capacity. Restricted capacity = (% of restricted lift) x ASME rated capacity.

CROSBY H-SERIES

SATURATED STEAM CAPACITIES

STYLES HE, HCI AND HSJ - USCS (UNITED STATES CUSTOMARY SYSTEM) UNITS - SATURATED STEAM CAPACITIES*

Pounds per hour at 3% overpressure

SATURATED STEAM CAPACITIES - SET PRESSURES 1100-1650 psig (continued)

HE HCI HSJ Set	Orifice designation and area (sq. in.)																		
	Orifice (sq. in.)																		
pres. psig	F	G	H	H2	J	J2	K	K2	L	L2	M	M2	N	P	P2	Q	Q2	R	RR
	0.307	0.503	0.785	0.994	1.288	1.431	1.840	2.545	2.853	3.341	3.600	3.976	4.341	6.380	7.070	11.045	12.250	16.000	19.290
1410	20364	33365	52071	65935	85437	94923	122053	168818	-	221619	-	263741	-	-	468976	-	812583	1061333	1279570
1420	20507	33599	52437	66398	86037	95589	122910	170003	-	223175	-	265593	-	-	472269	-	818288	1068785	1288554
1430	20650	33834	52802	66861	86637	96255	123767	171188	-	224731	-	267444	-	-	475562	-	823993	1076236	1297538
1440	20793	34068	53168	67324	87236	96922	124624	172374	-	226287	-	269296	-	-	478854	-	829699	1083688	1306522
1450	20852	34165	53319	67515	87485	97198	124979	172865	-	226932	-	270063	-	-	480219	-	832062	1086775	1310244
1460	21016	34433	53737	68045	88171	97960	125959	174220	-	228711	-	272181	-	-	483984	-	838586	1095296	1320516
1470	21158	34666	54102	68506	88769	98625	126813	175402	-	230262	-	274027	-	-	487266	-	844274	1102725	1329473
1480	21322	34935	54521	69037	89457	99389	127795	176761	-	232046	-	276150	-	-	491041	-	850815	1111268	1339773
1490	21465	35169	54886	69499	90055	100054	128651	177944	-	233599	-	277998	-	-	494328	-	856508	1118705	1348739
1500	21629	35438	55306	70031	90745	100820	129636	179306	-	235388	-	280126	-	-	498112	-	863066	1127270	1359065
1510	21772	35672	55671	70494	91344	101486	130492	180490	-	236942	-	281976	-	-	501402	-	-	1134715	-
1520	21937	35942	56093	71027	92035	102254	131479	181856	-	238735	-	284110	-	-	505196	-	-	1143302	-
1530	22102	36213	56515	71562	92728	103023	132469	183224	-	240532	-	286248	-	-	508998	-	-	1151905	-
1540	22245	36447	56881	72025	93328	103690	133326	184411	-	242089	-	288102	-	-	512294	-	-	1159364	-
1550	22410	36718	57304	72561	94023	104462	134318	185783	-	243890	-	290245	-	-	516105	-	-	1167989	-
1560	22554	36953	57670	73025	94624	105129	135177	186970	-	245449	-	292100	-	-	519404	-	-	1175456	-
1570	22719	37225	58095	73562	95320	105903	136171	188346	-	247255	-	294249	-	-	523225	-	-	1184103	-
1580	22863	37460	58461	74026	95921	106571	137031	189535	-	248816	-	296106	-	-	526528	-	-	1191577	-
1590	23029	37732	58887	74565	96619	107347	138028	190914	-	250626	-	298261	-	-	530359	-	-	1200246	-
1600	23196	38005	59313	75104	97318	108123	139027	192295	-	252440	-	300419	-	-	534196	-	-	1208931	-
1610	23340	38241	59680	75570	-	108793	139888	193486	-	254003	-	302280	-	-	537505	-	-	1216420	-
1620	23507	38514	60107	76111	-	109572	140889	194871	-	255821	-	304444	-	-	541353	-	-	1225127	-
1630	23650	38750	60475	76576	-	110242	141751	196064	-	257387	-	306307	-	-	544665	-	-	1232623	-
1640	23818	39025	60903	77119	-	111023	142755	197452	-	259210	-	308476	-	-	548522	-	-	1241353	-
1650	23986	39299	61332	77662	-	111805	143761	198843	-	261035	-	310649	-	-	552386	-	-	1250097	-

* Refer to capacity formula, page 52.

Capacities certified by the national board of boiler and pressure vessel inspectors in accordance with the ASME boiler and pressure vessel code. Section I, power boilers.

For superheated steam, multiply the saturated steam capacities by superheat correction factor K_{sh} , pages 62-63. Capacities for the HCI-R valves: valves adjust to a minimum of 30% of full rated capacity. Restricted capacity = (% of restricted lift) x ASME rated capacity.

CROSBY H-SERIES

SATURATED STEAM CAPACITIES

STYLES HE, HCI AND HSJ - USCS (UNITED STATES CUSTOMARY SYSTEM) UNITS - SATURATED STEAM CAPACITIES*

Pounds per hour at 3% overpressure

SATURATED STEAM CAPACITIES - SET PRESSURES 1650-2200 psig

HE HCI HSJ Set	Orifice designation and area (sq. in.)																		
	Orifice (sq. in.)																		
	pres. psig	F 0.307	G 0.503	H 0.785	H2 0.994	J 1.288	J2 1.431	K 1.840	K2 2.545	L 2.853	L2 3.341	M 3.600	M2 3.976	N 4.341	P 6.380	P2 7.070	Q 11.045	Q2 12.250	R 16.000
1660	24130	39536	61701	78128	-	112477	144624	200038	-	262604	-	312515	-	-	555705	-	-	1257608	-
1670	24298	39811	62131	78673	-	113261	145633	201432	-	264434	-	314694	-	-	559579	-	-	1266374	-
1680	24467	40087	62562	79219	-	114046	146642	202829	-	266268	-	316876	-	-	563459	-	-	1275156	-
1690	24611	40324	62931	79686	-	114719	147508	204026	-	267840	-	318746	-	-	566785	-	-	1282682	-
1700	24780	40601	63363	80233	-	115507	148520	205427	-	269678	-	320934	-	-	570675	-	-	1291486	-
1710	24949	40878	63796	80781	-	116296	149535	206829	-	271519	-	323125	-	-	574572	-	-	1300304	-
1720	25094	41115	64166	81249	-	116970	150402	208029	-	273094	-	324999	-	-	577904	-	-	1307846	-
1730	25263	41393	64599	81799	-	117761	151419	209435	-	274940	-	327196	-	-	581811	-	-	1316687	-
1740	25433	41671	65034	82349	-	118553	152437	210844	-	276789	-	329397	-	-	585724	-	-	1325542	-
1750	25578	41909	65405	82818	-	119229	153306	212046	-	278367	-	331275	-	-	589063	-	-	1333099	-
1760	25749	42188	65840	83370	-	120023	154327	213458	-	280221	-	333481	-	-	592986	-	-	1341977	-
1770	25919	42467	66277	83922	-	120818	155350	214872	-	282078	-	335691	-	-	596915	-	-	1350870	-
1780	26065	42706	66648	84393	-	121495	156220	216077	-	283659	-	337572	-	-	600261	-	-	1358441	-
1790	26236	42986	67085	84947	-	122292	157246	217495	-	285521	-	339788	-	-	604200	-	-	1367356	-
1800	26407	43267	67524	85501	-	123091	158273	218915	-	287385	-	342007	-	-	608146	-	-	1376287	-
1810	26553	43505	67896	85973	-	123770	159145	220122	-	288970	-	343892	-	-	611498	-	-	1383873	-
1820	26724	43786	68335	86529	-	124570	160174	221546	-	290839	-	346117	-	-	615454	-	-	1392825	-
1830	26896	44068	68775	87086	-	125372	161206	222972	-	292712	-	348345	-	-	619417	-	-	1401793	-
1840	27042	44307	69148	87558	-	126052	162080	224181	-	294299	-	350234	-	-	622776	-	-	1409394	-
1850	27215	44590	69589	88117	-	126856	163114	225611	-	296176	-	352468	-	-	626748	-	-	1418384	-
1860	27388	44873	70031	88676	-	127662	164149	227044	-	298056	-	354706	-	-	630727	-	-	1427389	-
1870	27561	45157	70473	89236	-	128468	165187	228478	-	299940	-	356947	-	-	634713	-	-	-	-
1880	27707	45396	70847	89710	-	129150	166063	229691	-	301531	-	358842	-	-	638081	-	-	-	-
1890	27880	45681	71291	90272	-	129959	167103	231129	-	303420	-	361088	-	-	642077	-	-	-	-
1900	28054	45965	71735	90834	-	130769	168145	232570	-	305311	-	363339	-	-	646079	-	-	-	-
1910	28228	46250	72180	91398	-	131580	169188	234013	-	307205	-	365594	-	-	650088	-	-	-	-
1920	28375	46491	72556	91873	-	132264	170067	235229	-	308802	-	367493	-	-	653466	-	-	-	-
1930	28549	46777	73002	92438	-	133077	171113	236675	-	310701	-	369753	-	-	657484	-	-	-	-
1940	28724	47063	73449	93004	-	133892	172161	238124	-	312603	-	372017	-	-	661510	-	-	-	-
1950	28899	47350	73896	93571	-	134708	173210	239576	-	314508	-	374284	-	-	665541	-	-	-	-
1960	29046	47591	74272	94047	-	135394	174092	240795	-	316109	-	376190	-	-	668930	-	-	-	-
1970	29222	47879	74721	94615	-	136212	175143	242250	-	318019	-	378463	-	-	672971	-	-	-	-
1980	29398	48167	75171	95184	-	137031	176197	243707	-	319932	-	380739	-	-	677019	-	-	-	-
1990	29574	48455	75621	95755	-	137852	177252	245167	-	321848	-	383020	-	-	681074	-	-	-	-

* Refer to capacity formula, page 52.

Capacities certified by the national board of boiler and pressure vessel inspectors in accordance with the ASME boiler and pressure vessel code. Section I, power boilers.

For superheated steam, multiply the saturated steam capacities by superheat correction factor K_{sh} , pages 62-63. Capacities for the HCI-R valves: valves adjust to a minimum of 30% of full rated capacity. Restricted capacity = [% of restricted lift] x ASME rated capacity.

CROSBY H-SERIES

SATURATED STEAM CAPACITIES

STYLES HE, HCI AND HSJ - USCS (UNITED STATES CUSTOMARY SYSTEM) UNITS - SATURATED STEAM CAPACITIES*

Pounds per hour at 3% overpressure

SATURATED STEAM CAPACITIES - SET PRESSURES 1650-2200 psig (continued)

		Orifice designation and area (sq. in.)																	
HE																			
HCI																			
HSJ																			
Set	Orifice (sq. in.)																		
pres.	F	G	H	H2	J	J2	K	K2	L	L2	M	M2	N	P	P2	Q	Q2	R	RR
psig	0.307	0.503	0.785	0.994	1.288	1.431	1.840	2.545	2.853	3.341	3.600	3.976	4.341	6.380	7.070	11.045	12.250	16.000	19.290
2000	29750	48744	76072	96326	-	138674	178309	246629	-	323767	348866	385304	-	-	685135	-	-	-	-
2010	29898	48986	76450	96804	-	139363	179195	247853	-	325375	350598	387217	-	-	688537	-	-	-	-
2020	30075	49276	76902	97376	-	140187	180254	249319	-	327299	352672	389506	-	-	692608	-	-	-	-
2030	30252	49566	77354	97949	-	141012	181315	250787	-	329226	354748	391799	-	-	696686	-	-	-	-
2040	30429	49856	77808	98524	-	141839	182378	252257	-	331156	356828	394096	-	-	700770	-	-	-	-
2050	30607	50147	78262	99099	-	142667	183443	253730	-	333089	358911	396397	-	-	704861	-	-	-	-
2060	30785	50439	78717	99675	-	143496	184509	255205	-	335025	360997	398701	-	-	708959	-	-	-	-
2070	30933	50682	79097	100156	-	144188	185399	256435	-	336641	362738	400624	-	-	712377	-	-	-	-
2080	31111	50974	79553	100733	-	145019	186468	257914	-	338582	364829	402934	-	-	716484	-	-	-	-
2090	31290	51267	80009	101311	-	145852	187539	259395	-	340526	366924	405247	-	-	720598	-	-	-	-
2100	31469	51560	80467	101891	-	146686	188611	260878	-	342473	369022	407565	-	-	724719	-	-	-	-
2110	31648	51854	80925	102471	-	147521	189685	262364	-	344423	371124	409886	-	-	728846	-	-	-	-
2120	31828	52148	81384	103052	-	148358	190761	263852	-	346377	373229	412210	-	-	732980	-	-	-	-
2130	32007	52442	81844	103634	-	149196	191839	265342	-	348333	375337	414539	-	-	737120	-	-	-	-
2140	32188	52738	82304	104217	-	150035	192918	266835	-	350293	377448	416871	-	-	741267	-	-	-	-
2150	32368	53033	82766	104801	-	150876	193999	268330	-	352256	379563	419207	-	-	745421	-	-	-	-
2160	32517	53278	83148	105286	-	151573	194895	269570	-	353884	381317	421144	-	-	748865	-	-	-	-
2170	32698	53574	83610	105871	-	152416	195979	271069	-	355851	383437	423485	-	-	753029	-	-	-	-
2180	32879	53871	84073	106457	-	153260	197064	272570	-	357822	385561	425830	-	-	757199	-	-	-	-
2190	33061	54168	84537	107044	-	154105	198151	274073	-	359795	387687	428179	-	-	761375	-	-	-	-
2200	33242	54466	85001	107633	-	154952	199240	275579	-	361772	389817	430532	-	-	765558	-	-	-	-

* Refer to capacity formula, page 52.

Capacities certified by the national board of boiler and pressure vessel inspectors in accordance with the ASME boiler and pressure vessel code. Section I, power boilers.

For superheated steam, multiply the saturated steam capacities by superheat correction factor K_{sh} , pages 62-63. Capacities for the HCI-R valves: valves adjust to a minimum of 30% of full rated capacity. Restricted capacity = (% of restricted lift) x ASME rated capacity.

CROSBY H-SERIES

SATURATED STEAM CAPACITIES

STYLES HE, HCI AND HSJ - USCS (UNITED STATES CUSTOMARY SYSTEM) UNITS - SATURATED STEAM CAPACITIES*

Pounds per hour at 3% overpressure

SATURATED STEAM CAPACITIES - SET PRESSURES 2210-2750 psig

		Orifice designation and area (sq. in.)																	
HE																			
HCI																			
HSJ																			
Set	Orifice (sq. in.)																		
pres.	F	G	H	H2	J	J2	K	K2	L	L2	M	M2	N	P	P2	Q	Q2	R	RR
psig	0.307	0.503	0.785	0.994	1.288	1.431	1.840	2.545	2.853	3.341	3.600	3.976	4.341	6.380	7.070	11.045	12.250	16.000	19.290
2210	33424	54764	85467	108222	-	155800	200330	277087	-	363752	391951	432888	-	-	769748	-	-	-	-
2220	33606	55062	85933	108812	-	156649	201422	278598	-	365735	394088	435248	-	-	773945	-	-	-	-
2230	33789	55361	86399	109402	-	157500	202516	280111	-	367721	396228	437611	-	157500	778148	-	-	-	-
2240	33972	55661	86867	109994	-	158352	203612	281626	-	369710	398371	439979	-	-	782357	-	-	-	-
2250	34155	55961	87335	110587	-	159206	204709	283144	-	371703	400518	442350	-	-	786573	-	-	-	-
2260	34338	56261	87804	111181	-	160060	205808	284664	-	373698	402668	444725	-	-	790796	-	-	-	-
2270	34522	56562	88273	111775	-	160916	206909	286186	-	375697	404822	447103	-	-	795025	-	-	-	-
2280	34706	56864	88744	112371	-	161774	208011	287711	-	377699	406979	449485	-	-	799261	-	-	-	-
2290	34890	57165	89215	112967	-	162632	209115	289238	-	379703	409139	451871	-	-	803504	-	-	-	-
2300	35074	57468	89686	113565	-	163492	210221	290768	-	381711	411302	454261	-	-	807753	-	-	-	-
2310	35259	57770	90159	114163	-	164354	211328	292300	-	383722	413469	456654	-	-	812008	-	-	-	-
2320	35444	58074	90632	114762	-	165216	212438	293834	-	385737	415640	459051	-	-	816270	-	-	-	-
2330	35630	58377	91106	115363	-	166080	213549	295371	-	387754	417813	461452	-	-	820539	-	-	-	-
2340	35849	58737	91667	116073	-	167103	214863	297189	-	390141	420385	464292	-	-	825590	-	-	-	-
2350	36035	59042	92143	116675	-	167970	215978	298731	-	392166	422567	466702	-	-	829875	-	-	-	-
2360	36221	59347	92619	117278	-	168839	217095	300276	-	394194	424752	469115	-	-	834167	-	-	-	-
2370	36408	59653	93096	117883	-	169709	218214	301824	-	396225	426941	471533	-	-	838465	-	-	-	-
2380	36595	59959	93574	118488	-	170580	219335	303373	-	398259	429133	473954	-	-	842770	-	-	-	-
2390	36782	60266	94053	119094	-	171453	220457	304925	-	400297	431329	476379	-	-	847082	-	-	-	-
2400	36970	60573	94533	119701	-	172327	221580	306480	-	402338	433527	478807	-	-	851400	-	-	-	-
2410	37158	60881	95013	120309	-	173202	222706	308036	-	404381	435730	481239	-	-	855725	-	-	-	-
2420	37380	61246	95583	121031	-	174241	224042	309884	-	406807	438343	484126	-	-	860858	-	-	-	-
2430	37569	61555	96065	121641	-	175120	225172	311447	-	408858	440554	486567	-	-	865199	-	-	-	-
2440	37758	61864	96548	122253	-	176000	226303	313012	-	410913	442768	489012	-	-	869547	-	-	-	-
2450	37947	62174	97031	122865	-	176881	227436	314579	-	412971	444985	491461	-	-	873901	-	-	-	-
2460	38136	62484	97515	123478	-	177764	228571	316149	-	415032	447206	493914	-	-	878262	-	-	-	-
2470	38361	62853	98091	124207	-	178813	229921	318016	-	417482	449846	496830	-	-	883448	-	-	-	-
2480	38551	63164	98577	124823	-	179700	231060	319592	-	419551	452075	499292	-	-	887826	-	-	-	-
2490	38742	63476	99064	125439	-	180587	232201	321170	-	421622	454307	501757	-	-	892210	-	-	-	-
2500	38933	63789	99551	126056	-	181476	233344	322750	-	423697	456543	504226	-	-	896600	-	-	-	-

* Refer to capacity formula, page 52.

Capacities certified by the national board of boiler and pressure vessel inspectors in accordance with the ASME boiler and pressure vessel code. Section I, power boilers.

For superheated steam, multiply the saturated steam capacities by superheat correction factor K_{sh} , pages 62-63. Capacities for the HCI-R valves: valves adjust to a minimum of 30% of full rated capacity. Restricted capacity = [% of restricted lift] x ASME rated capacity.

CROSBY H-SERIES

SATURATED STEAM CAPACITIES

STYLES HE, HCI AND HSJ - USCS (UNITED STATES CUSTOMARY SYSTEM) UNITS - SATURATED STEAM CAPACITIES*

Pounds per hour at 3% overpressure

SATURATED STEAM CAPACITIES - SET PRESSURES 2210-2750 psig (continued)

HE HCI HSJ Set	Orifice designation and area (sq. in.)																		
	Orifice (sq. in.)																		
pres. psig	F 0.307	G 0.503	H 0.785	H2 0.994	J 1.288	J2 1.431	K 1.840	K2 2.545	L 2.853	L2 3.341	M 3.600	M2 3.976	N 4.341	P 6.380	P2 7.070	Q 11.045	Q2 12.250	R 16.000	RR 19.290
2510	39160	64161	100132	126791	-	182534	234705	324632	-	426168	459205	507167	-	-	901829	-	-	-	-
2520	39351	64474	100621	127411	-	183426	235852	326219	-	428251	461449	509645	-	-	906236	-	-	-	-
2530	39543	64788	101111	128031	-	184319	237000	327808	-	430336	463697	512127	-	-	910649	-	-	-	-
2540	39771	65163	101695	128771	-	185384	238370	329702	-	432823	466376	515086	-	-	915911	-	-	-	-
2550	39963	65478	102187	129394	-	186281	239523	331296	-	434916	468632	517578	-	-	920341	-	-	-	-
2560	40156	65793	102680	130018	-	187179	240677	332893	-	437013	470891	520073	-	-	924778	-	-	-	-
2570	40386	66170	103268	130762	-	188250	242055	334799	-	439515	473587	523050	-	-	930072	-	-	-	-
2580	40579	66487	103762	131388	-	189152	243214	336402	-	441619	475854	525554	-	-	934525	-	-	-	-
2590	40773	66804	104257	132015	-	190054	244375	338008	-	443727	478125	528063	-	-	938985	-	-	-	-
2600	41004	67183	104849	132764	-	191133	245761	339925	-	446244	480838	531058	-	-	944312	-	-	-	-
2610	41199	67502	105346	133394	-	192039	246926	341537	-	448359	483117	533576	-	-	948788	-	-	-	-
2620	41431	67882	105940	134146	-	193122	248319	343463	-	450888	485841	536585	-	-	954139	-	-	-	-
2630	41626	68202	106439	134777	-	194031	249488	345080	-	453011	488129	539111	-	-	958631	-	-	-	-
2640	41859	68584	107035	135533	-	195118	250886	347014	-	455550	490865	542133	-	-	964005	-	-	-	-
2650	42055	68905	107536	136167	-	196031	252060	348637	-	457681	493161	544669	-	-	968514	-	-	-	-
2660	42251	69226	108037	136802	-	196945	253235	350263	-	459815	495460	547208	-	-	973029	-	-	-	-
2670	42486	69611	108638	137562	-	198039	254642	352209	-	462369	498213	550249	-	-	978436	-	-	-	-
2680	42721	69997	-	138324	-	199136	256052	354160	-	464930	500973	553296	-	-	983855	-	-	-	-
2690	42919	70320	-	138962	-	200056	257235	355795	-	467077	503285	555851	-	-	988397	-	-	-	-
2700	43155	70707	-	139728	-	201157	258651	357754	-	469649	506057	558912	-	-	993840	-	-	-	-
2710	-	-	-	140368	-	202080	259837	359395	-	471803	508378	561475	-	-	998398	-	-	-	-
2720	-	-	-	141137	-	203186	261260	361362	-	474386	511161	564549	-	-	1003864	-	-	-	-
2730	-	-	-	141780	-	204112	262450	363009	-	476548	513490	567122	-	-	1008439	-	-	-	-
2740	-	-	-	142552	-	205223	263879	364985	-	479141	516285	570208	-	-	1013927	-	-	-	-
2750	-	-	-	143325	-	206337	265311	366965	-	481741	519087	573302	-	-	1019429	-	-	-	-

* Refer to capacity formula, page 52.

Capacities certified by the national board of boiler and pressure vessel inspectors in accordance with the ASME boiler and pressure vessel code. Section I, power boilers.

For superheated steam, multiply the saturated steam capacities by superheat correction factor K_{sh} , pages 62-63. Capacities for the HCI-R valves: valves adjust to a minimum of 30% of full rated capacity. Restricted capacity = (% of restricted lift) x ASME rated capacity.

CROSBY H-SERIES
SATURATED STEAM CAPACITIES

STYLES HE, HCI AND HSJ - USCS (UNITED STATES CUSTOMARY SYSTEM) UNITS - SATURATED STEAM CAPACITIES*

Pounds per hour at 3% overpressure

SATURATED STEAM CAPACITIES - SET PRESSURES 2760-3090 psig

		Orifice designation and area (sq. in.)																		
HE																				
HCI																				
HSJ																				
Set		Orifice (sq. in.)																		
pres.	psig	F	G	H	H2	J	J2	K	K2	L	L2	M	M2	N	P	P2	Q	Q2	R	RR
		0.307	0.503	0.785	0.994	1.288	1.431	1.840	2.545	2.853	3.341	3.600	3.976	4.341	6.380	7.070	11.045	12.250	16.000	19.290
2760	-	-	-	-	143972	-	207268	266508	368622	-	483916	521430	575890	-	-	1024030	-	-	-	-
2770	-	-	-	-	144749	-	208386	267946	370610	-	486526	524243	578997	-	-	1029555	-	-	-	-
2780	-	-	-	-	145527	-	209507	269387	372604	-	489143	527063	582111	-	-	1035093	-	-	-	-
2790	-	-	-	-	146308	-	210631	270832	374602	-	491767	529889	585233	-	-	1040644	-	-	-	-
2800	-	-	-	-	146960	-	211569	272039	376271	-	493958	532251	587841	-	-	1045282	-	-	-	-
2810	-	-	-	-	147744	-	212698	273490	378278	-	496592	535089	590976	-	-	1050856	-	-	-	-
2820	-	-	-	-	148529	-	213828	274944	380289	-	499233	537934	594118	-	-	1056443	-	-	-	-
2830	-	-	-	-	149317	-	214962	276401	382305	-	501879	540786	597268	-	-	1062044	-	-	-	-
2840	-	-	-	-	150106	-	216098	277862	384326	-	504532	543644	600425	-	-	1067657	-	-	-	-
2850	-	-	-	-	150764	-	217046	279081	386012	-	506745	546029	603059	-	-	1072341	-	-	-	-
2860	-	-	-	-	151557	-	218187	280548	388041	-	509409	548899	606229	-	-	1077978	-	-	-	-
2870	-	-	-	-	152351	-	219331	282019	390075	-	512079	551776	609406	-	-	1083628	-	-	-	-
2880	-	-	-	-	153147	-	220477	283493	392113	-	514755	554660	612591	-	-	1089291	-	-	-	-
2890	-	-	-	-	153945	-	221626	284970	394157	-	517437	557550	615783	-	-	1094967	-	-	-	-
2900	-	-	-	-	154745	-	222777	286450	396205	-	520126	560447	618983	-	-	1100656	-	-	-	-
2910	-	-	-	-	155547	-	223932	287935	398258	-	522821	563351	622190	-	-	1106359	-	-	-	-
2920	-	-	-	-	156351	-	225089	289422	400315	-	525522	566261	625404	-	-	1112074	-	-	-	-
2930	-	-	-	-	157156	-	226248	290913	402377	-	528229	569178	628626	-	-	1117803	-	-	-	-
2940	-	-	-	-	157963	-	227410	292407	404444	-	530942	572102	631855	-	-	1123545	-	-	-	-
2950	-	-	-	-	158773	-	228575	293905	406516	-	533662	575033	635092	-	-	1129301	-	-	-	-
2960	-	-	-	-	159721	-	229941	295661	408945	-	536851	578469	638886	-	-	1136048	-	-	-	-
2970	-	-	-	-	160535	-	231112	297167	411027	-	539585	581414	642140	-	-	1141833	-	-	-	-
2980	-	-	-	-	161350	-	232285	298676	413114	-	542325	584366	645400	-	-	1147631	-	-	-	-
2990	-	-	-	-	162167	-	233462	300188	415206	-	545071	587326	648668	-	-	1153443	-	-	-	-
3000	-	-	-	-	162986	-	234640	301704	417303	-	547823	590291	651944	-	-	1159267	-	-	-	-
3010	-	-	-	-	163946	-	236024	303483	419763	-	551052	593771	655787	-	-	1166100	-	-	-	-
3020	-	-	-	-	164769	-	237208	305006	421870	-	553819	596752	659079	-	-	1171954	-	-	-	-
3030	-	-	-	-	165594	-	238396	306533	423982	-	556591	599739	662379	-	-	1177822	-	-	-	-
3040	-	-	-	-	166562	-	239790	308325	426461	-	559845	603245	666251	-	-	1184708	-	-	-	-
3050	-	-	-	-	167391	-	240983	309860	428584	-	562632	606248	669567	-	-	1190604	-	-	-	-
3060	-	-	-	-	168365	-	242384	311661	431075	-	565903	609773	673460	-	-	1197527	-	-	-	-
3070	-	-	-	-	169198	-	243584	313204	433209	-	568704	612791	676793	-	-	1203453	-	-	-	-
3080	-	-	-	-	170176	-	244992	315015	435714	-	571992	616334	680707	-	-	1210412	-	-	-	-
3090	-	-	-	-	171014	-	246198	316565	437858	-	574807	619367	684056	-	-	1216368	-	-	-	-
3100	-	-	-	-	171997	-	247614	-	440376	-	578112	-	687990	-	-	1223363	-	-	-	-

Capacities certified by the national board of boiler and pressure vessel inspectors in accordance with the ASME boiler and pressure vessel code. Section I, power boilers.

For superheated steam, multiply the saturated steam capacities by superheat correction factor K_{sh} , pages 62-63. Capacities for the HCI-R valves: valves adjust to a minimum of 30% of full rated capacity. Restricted capacity = (% of restricted lift) x ASME rated capacity.

For steam capacities at 10% overpressure up to absolute pressure of 1500 psia, multiply the capacity from above table by ratio $\frac{1.10p + 14.7}{1.03p + 14.7}$ where p is set pressure (psig)

* Capacity formula:
 $W = (51.5 \times AP \times K)$
 For pressures over 1500 psig and up to 3200 psig the value of W shall be multiplied by $\frac{0.1906P - 1000}{0.2292P - 1061}$

where:
 W = Rated capacity, lbs/hr
 $P = (1.03 \times \text{set pressure}) + 14.7 = \text{absolute pressure, psia}$
 $K = 0.878 = \text{average coefficient of discharge}$
 $A = \text{Nozzle throat (orifice) area, sq.in.}$

CROSBY H-SERIES

SATURATED STEAM CAPACITIES

STYLES HE, HCI AND HSJ - METRIC UNITS - SATURATED STEAM CAPACITIES

Kilograms per hour at 3% overpressure

SATURATED STEAM CAPACITIES - SET PRESSURES 1-43 barg

HE HCI HSJ Set	Orifice designation and area (sq. mm)																		
	Orifice (sq. mm)																		
pres. barg	F	G	H	H2	J	J2	K	K2	L	L2	M	M2	N	P	P2	Q	Q2	R	RR
	198.1	324.5	506.5	641.3	830.0	923.2	1187.1	1641.9	1840.6	2155.5	2322.6	2565.2	2800.6	4116.1	4561.3	7125.8	7903.2	10322.6	12445.1
1.034	200	327	510	-	837	-	1196	-	1855	-	2340	-	2822	4148	-	7180	-	-	-
2	288	471	736	-	1207	-	1725	-	2674	-	3375	-	4069	5981	-	10354	-	-	-
3	379	621	969	-	1590	-	2272	-	3523	-	4446	-	5361	7879	-	13640	-	-	-
4	470	771	1203	-	1974	-	2820	-	4372	-	5517	-	6652	9777	-	16925	-	-	-
5	562	922	1439	-	2361	-	3373	-	5231	-	6600	-	7959	11697	-	20251	-	-	-
6	657	1076	1680	-	2756	-	3937	-	6105	-	7703	-	9289	13652	-	23635	-	-	-
7	751	1230	1920	-	3151	-	4501	-	6979	-	8806	-	10619	15607	-	27019	-	-	-
8	845	1384	2160	-	3545	-	5065	-	7853	-	9910	-	11949	17562	-	30403	-	-	-
9	939	1539	2401	-	3940	-	5629	-	8727	-	11012	-	13279	19517	-	33787	-	-	-
10	1033	1693	2642	-	4335	-	6192	-	9602	-	12115	-	14609	21472	-	37171	-	-	-
11	1127	1847	2882	-	4729	-	6756	-	10476	-	13219	-	15939	23426	-	40556	-	-	-
12	1221	2001	3123	-	5124	-	7320	-	11350	-	14322	-	17270	25381	-	43940	-	-	-
13	1315	2155	3363	-	5518	-	7883	-	12224	-	15424	-	18600	27336	-	47324	-	-	-
14	1409	2309	3604	-	5913	-	8447	-	13098	-	16528	-	19929	29291	-	50708	-	-	-
15	1503	2463	3844	-	6308	-	9011	-	13972	-	17631	-	21260	31246	-	54092	-	-	-
16	1598	2617	4085	-	6702	-	9575	-	14847	-	18734	-	22590	33200	-	57477	-	-	-
17	1691	2771	4325	-	7097	-	10139	-	15721	-	19837	-	23920	35155	-	60861	-	-	-
18	1785	2926	4566	-	7492	-	10703	-	16595	-	20940	-	25250	37110	-	64245	-	-	-
19	1880	3080	4806	-	7886	-	11266	-	17469	-	22043	-	26580	39065	-	67629	-	-	-
20	1974	3234	5047	6391	8281	9200	11830	16363	18343	21481	23146	25563	27910	41020	45456	71013	78760	102871	124024
21	2067	3388	5288	6695	8675	9639	12394	17143	19217	22504	24249	26781	29240	42975	47622	74397	82514	107774	129934
22	2162	3542	5528	7000	9070	10077	12957	17922	20091	23528	25352	28000	30570	44929	49789	77782	86267	112676	135845
23	2256	3696	5768	7304	9465	10516	13521	18702	20965	24552	26455	29218	31900	46884	51955	81166	90021	117578	141755
24	2350	3850	6009	7609	9859	10954	14085	19482	21840	25575	27558	30436	33230	48839	54121	84550	93774	122480	147666
25	2444	4004	6250	7913	10254	11392	14649	20262	22714	26599	28661	31654	34561	50794	56287	87934	97527	127383	153576
26	2538	4159	6490	8218	10649	11831	15213	21041	23588	27622	29764	32873	35890	52749	58454	91318	101281	132285	159486
27	2632	4313	6730	8523	11044	12270	15776	21821	24462	28646	30867	34091	37220	54703	60619	94702	105034	137188	165397
28	2726	4467	6971	8827	11438	12708	16340	22601	25336	29670	31970	35309	38551	56658	62786	98087	108788	142090	171307
29	2820	4621	7212	9132	11833	13146	16904	23381	26210	30694	33073	36527	39881	58613	64952	101470	112541	146993	177218
30	2914	4775	7452	9436	12227	13585	17468	24161	27084	31717	34176	37746	41211	60568	67119	104855	116294	151895	183128
31	3008	4929	7692	9741	12622	14023	18032	24940	27959	32741	35279	38964	42541	62523	69284	108239	120048	156797	189039
32	3103	5083	7933	10045	13017	14462	18595	25720	28833	33765	36382	40182	43871	64478	71451	111623	123801	161699	194949
33	3196	5237	8174	10350	13411	14900	19159	26500	29707	34788	37485	41400	45201	66432	73617	115007	127554	166602	200859
34	3290	5391	8414	10654	13806	15339	19723	27279	30581	35812	38588	42619	46531	68387	75783	118391	131308	171504	206770
35	3385	5546	8655	10959	14201	15777	20286	28060	31455	36836	39691	43837	47861	70342	77949	121775	135061	176407	212680
36	3479	5700	8895	11264	14595	16215	20850	28839	32329	37860	40794	45055	49191	72297	80116	125160	138815	181309	218591
37	3572	5854	9136	11568	14990	16654	21414	29619	33203	38883	41897	46273	50521	74252	82282	128544	142568	186211	224501
38	3667	6008	9376	11873	15384	17093	21978	30399	34078	39907	43001	47492	51852	76206	84448	131928	146321	191113	230411
39	3761	6162	9617	12177	15779	17531	22542	31179	34952	40930	44103	48710	53181	78161	86614	135312	150075	196016	236322
40	3855	6316	9857	12482	16174	17970	23106	31958	35826	41954	45206	49928	54511	80116	88781	138696	153828	200918	242232
41	3949	6470	10098	12786	16568	18408	23669	32738	36700	42978	46310	51146	55842	82071	90947	142081	157582	205821	248143
42	4043	6624	10338	13091	16963	18846	24233	33518	37574	44002	47413	52365	57172	84026	93113	145465	161335	210723	254053
43	4137	6778	10579	13395	17358	19285	24797	34298	38449	45025	48515	53583	58502	85981	95279	-	165088	215626	259963

Capacities certified by the national board of boiler and pressure vessel inspectors in accordance with the ASME boiler and pressure vessel code. Section I, power boilers.

For superheated steam, multiply the saturated steam capacities by superheat correction factor K_{sh} , pages 62-63. Capacities for the HCI-R valves: valves adjust to a minimum of 30% of full rated capacity. Restricted capacity = (% of restricted lift) x ASME rated capacity.

Capacity formula: capacity is calculated by converting valve set pressure in barg or kPag psig, calculating in pounds per hour by ASME Section I capacity formula, and converting to kilograms per hour.

CROSBY H-SERIES

SATURATED STEAM CAPACITIES

STYLES HE, HCI AND HSJ - METRIC UNITS - SATURATED STEAM CAPACITIES

Kilograms per hour at 3% overpressure

SATURATED STEAM CAPACITIES - SET PRESSURES 44-86 barg

Set pres. barg	Orifice designation and area (sq. mm)																		
	F	G	H	H2	J	J2	K	K2	L	L2	M	M2	N	P	P2	Q	Q2	R	RR
	198.1	324.5	506.5	641.3	830.0	923.2	1187.1	1641.9	1840.6	2155.5	2322.6	2565.2	2800.6	4116.1	4561.3	7125.8	7903.2	10322.6	12445.1
44	4231	6933	10820	13700	17752	19723	25360	35078	39323	46049	49618	54801	59832	87935	97446	-	168842	220528	265874
45	4325	7087	11060	14005	18147	20162	25924	35857	40197	47072	50722	56019	61162	89890	99612	-	172595	225430	271784
46	4419	7241	11300	14309	18541	20600	26488	36637	41071	48096	51825	57237	62492	91845	101778	-	176348	230332	277695
47	4513	7395	11541	14614	18936	21039	27052	37417	41945	49120	52928	58456	63822	93800	103944	-	180102	235235	283605
48	4608	7549	11782	14918	19331	21477	27616	38197	42819	50143	54031	59674	65152	95755	106111	-	183855	240137	289516
49	4701	7703	12022	15223	19725	21915	28179	38976	43694	51167	55134	60892	66482	97709	108277	-	187609	245040	295426
50	4795	7857	12262	15527	20120	22354	28743	39756	44568	52191	56237	62110	67812	99664	110443	-	191362	249942	301336
51	4890	8011	12503	15832	20515	22793	29307	40536	45442	53215	57340	63329	69142	101619	112609	-	195115	254845	307247
52	4984	8166	12744	16137	20909	23231	29871	41316	46316	54238	58443	64547	70472	103574	114776	-	198869	259747	313157
53	5078	8320	12984	16441	21304	23669	30434	42096	47190	55262	59546	65765	71802	105529	116942	-	202622	264649	319068
54	5172	8474	13224	16746	21698	24108	30998	42875	48064	56285	60649	66983	73133	107484	119108	-	206375	269551	324978
55	5266	8628	13465	17050	22093	24546	31562	43655	48939	57309	61752	68202	74463	109438	121274	-	210128	274454	330888
56	5360	8782	13706	17355	22488	24985	32126	44435	49813	58333	62855	69420	75793	111393	123441	-	213882	279356	336799
57	5454	8936	13946	17659	22883	25423	32689	45215	50687	59357	63958	70638	77123	113348	125607	-	217635	284259	342709
58	5548	9090	14187	17964	23277	25862	33253	45994	51561	60380	65061	71856	78453	115303	127773	-	221389	289161	348620
59	5642	9244	14427	18268	23672	26300	33817	46774	52435	61404	66164	73075	79783	117258	129939	-	225142	294063	354530
60	5736	9398	14668	18573	24067	26738	34381	47554	53309	62427	67267	74293	81113	119212	132105	-	228895	298966	360440
61	5830	9553	14908	18878	24461	27177	34945	48334	54183	63451	68370	75511	82443	121167	134272	-	232649	303868	366351
62	5924	9707	15149	19182	24856	27616	35509	49114	55057	64475	69473	76729	83773	123122	136438	-	236402	308770	372261
63	6018	9861	15389	19487	25251	28054	36072	49893	55932	65499	70576	77948	85103	125077	138604	-	240156	313673	378172
64	6113	10015	15630	19791	25645	28492	36636	50673	-	66522	-	79166	-	140770	-	243909	318575	384082	
65	6207	10169	15870	20096	26040	28931	37200	51453	-	67546	-	80384	-	142936	-	247662	323478	389993	
66	6300	10323	16111	20400	26434	29369	37763	52233	-	68570	-	81602	-	145103	-	251416	328380	395903	
67	6395	10478	16352	20705	26829	29808	38327	53013	-	69593	-	82821	-	147269	-	255169	333282	401813	
68	6489	10631	16592	21009	27224	30246	38891	53792	-	70617	-	84039	-	149435	-	258922	338184	407724	
69	6583	10786	16832	21314	27618	30685	39455	54572	-	71641	-	85257	-	151601	-	262676	343087	413635	
70	6677	10940	17073	21619	28013	31123	40019	55352	-	72664	-	86475	-	153768	-	266429	347989	419545	
71	6771	11094	17314	21923	28408	31561	40582	56132	-	73688	-	87693	-	155934	-	270183	352892	425455	
72	6865	11248	17554	22228	28802	32000	41146	56911	-	74712	-	88912	-	158100	-	273936	357794	431365	
73	6959	11402	17794	22532	29197	32439	41710	57691	-	75735	-	90130	-	160266	-	277689	362697	437276	
74	7053	11556	18035	22837	29591	32877	42273	58471	-	76759	-	91348	-	162433	-	281443	367599	443187	
75	7147	11710	18276	23141	29986	33315	42837	59251	-	77783	-	92566	-	164599	-	285196	372501	449097	
76	7241	11865	18516	23446	30381	33754	43401	60031	-	78806	-	93785	-	166765	-	288950	377403	455007	
77	7335	12018	18756	23751	30775	34192	-	60810	-	79830	-	95003	-	168931	-	292703	382306	460917	
78	7429	12173	18997	24055	31170	34631	-	61590	-	80854	-	96221	-	171097	-	296456	387208	466828	
79	7523	12327	19238	24360	31565	35069	-	62370	-	81878	-	97439	-	173264	-	300210	392111	472739	
80	7618	12481	19478	24664	31959	35508	-	63150	-	82901	-	98658	-	175430	-	303963	397013	478649	
81	7712	12635	19719	24969	32354	35946	-	63929	-	83925	-	99876	-	177596	-	307717	401915	484559	
82	7805	12789	19959	25273	32748	36384	-	64709	-	84948	-	101094	-	179762	-	311470	406818	490470	
83	7900	12943	20200	25578	33143	36823	-	65489	-	85972	-	102312	-	181929	-	315223	411720	496380	
84	7994	13097	20440	25882	33538	37261	-	66269	-	86996	-	103531	-	184095	-	318977	416622	502291	
85	8088	13251	20681	26187	33932	37700	-	67049	-	88020	-	104749	-	186261	-	322730	421525	508201	
86	8182	13405	20921	26492	34327	38139	-	67828	-	89043	-	105967	-	188427	-	326483	426427	514111	

Capacities certified by the national board of boiler and pressure vessel inspectors in accordance with the ASME boiler and pressure vessel code. Section I, power boilers.

For superheated steam, multiply the saturated steam capacities by superheat correction factor K_{sh} , pages 62-63. Capacities for the HCI-R valves: valves adjust to a minimum of 30% of full rated capacity. Restricted capacity = (% of restricted lift) x ASME rated capacity.

Capacity formula: capacity is calculated by converting valve set pressure in barg or kPag psig, calculating in pounds per hour by ASME Section I capacity formula, and converting to kilograms per hour.

CROSBY H-SERIES

SATURATED STEAM CAPACITIES

STYLES HE, HCI AND HSJ - METRIC UNITS - SATURATED STEAM CAPACITIES

Kilograms per hour at 3% overpressure

SATURATED STEAM CAPACITIES - SET PRESSURES 87-129 barg

		Orifice designation and area (sq. mm)																	
HE																			
HCI																			
HSJ																			
Set	Orifice (sq. mm)																		
pres.	F	G	H	H2	J	J2	K	K2	L	L2	M	M2	N	P	P2	Q	Q2	R	RR
barg	198.1	324.5	506.5	641.3	830.0	923.2	1187.1	1641.9	1840.6	2155.5	2322.6	2565.2	2800.6	4116.1	4561.3	7125.8	7903.2	10322.6	12445.1
87	8276	13560	21162	26796	34722	38577	-	68608	-	90067	-	107185	-	-	190594	-	330237	431330	520022
88	8370	13714	21402	27101	35117	39015	-	69388	-	91090	-	108404	-	-	192760	-	333990	436232	525932
89	8464	13868	21643	27405	35511	39454	-	70168	-	92114	-	109621	-	-	194926	-	337744	441134	531842
90	8558	14022	21884	27710	35906	39892	-	70947	-	93138	-	110840	-	-	197092	-	341497	446037	537753
91	8652	14176	22124	28014	36301	40331	-	71727	-	94162	-	112058	-	-	199259	-	345250	450939	543664
92	8746	14330	22364	28319	36695	40769	-	72507	-	95185	-	113277	-	-	201425	-	349003	455841	549574
93	8841	14485	22605	28623	37090	41208	-	73287	-	96209	-	114495	-	-	203591	-	352757	460744	555484
94	8934	14638	22846	28928	37484	41646	-	74067	-	97233	-	115713	-	-	205757	-	356510	465646	561394
95	9028	14793	23086	29233	37879	42084	-	74846	-	98256	-	116931	-	-	207924	-	360263	470549	567305
96	9123	14947	23326	29537	38274	42523	-	75626	-	99280	-	118149	-	-	210090	-	364017	475451	573216
97	9217	15101	23567	29842	38668	42962	-	76406	-	100304	-	119368	-	-	212256	-	367770	480353	579126
98	9310	15255	23808	30146	39063	43400	-	77186	-	101327	-	120586	-	-	214422	-	371524	485255	585036
99	9405	15409	24048	30451	39458	43838	-	77966	-	102351	-	121804	-	-	216589	-	375277	490158	590947
100	9461	15501	24191	30632	39693	44100	-	78430	-	102961	-	122530	-	-	217879	-	377514	493080	594470
101	9564	15670	24455	30967	40126	44581	-	79287	-	104085	-	123868	-	-	220258	-	381635	498463	600959
102	9667	15840	24720	31302	40560	45063	-	80144	-	105211	-	125208	-	-	222641	-	385764	503855	607460
103	9771	16010	24985	31638	40995	45547	-	81003	-	106339	-	126550	-	-	225028	-	389900	509258	613974
104	9865	16163	25226	31942	41389	45985	-	81783	-	107362	-	127767	-	-	227192	-	393650	514155	619878
105	9969	16334	25491	32278	41825	46469	-	82644	-	108493	-	129114	-	-	229586	-	-	519572	-
106	10073	16504	25758	32616	42262	46955	-	83507	-	109626	-	130462	-	-	231984	-	-	524999	-
107	10178	16675	26024	32953	42700	47441	-	84372	-	110761	-	131813	-	-	234386	-	-	530435	-
108	10282	16846	26292	33291	43138	47928	-	85239	-	111899	-	133167	-	-	236793	-	-	535882	-
109	10387	17018	26559	33630	43578	48416	-	86106	-	113038	-	134522	-	-	239204	-	-	541338	-
110	10481	17173	26801	33936	43974	48856	-	86889	-	114066	-	135746	-	-	241379	-	-	546260	-
111	10586	17345	27069	34276	44414	49345	-	87760	-	115208	-	137105	-	-	243796	-	-	551731	-
112	10691	17517	27338	34617	-	49835	-	88631	-	116353	-	138467	-	-	246218	-	-	557212	-
113	10797	17690	27607	34958	-	50327	-	89505	-	117499	-	139832	-	-	248644	-	-	562703	-
114	10902	17862	27877	35299	-	50819	-	90380	-	118648	-	141198	-	-	251075	-	-	568203	-
115	11008	18036	28148	35642	-	51311	-	91256	-	119798	-	142568	-	-	253510	-	-	573713	-
116	11114	18209	28418	35985	-	51805	-	92134	-	120951	-	143939	-	-	255949	-	-	579233	-
117	11220	18383	28690	36328	-	52300	-	93014	-	122106	-	145313	-	-	258392	-	-	584763	-
118	11326	18557	28961	36672	-	52795	-	93895	-	123262	-	146690	-	-	260840	-	-	590302	-
119	11433	18732	29234	37017	-	53291	-	94778	-	124421	-	148069	-	-	263292	-	-	595852	-
120	11539	18907	29507	37362	-	53788	-	95662	-	125582	-	149451	-	-	265748	-	-	601411	-
121	11646	19082	29780	37708	-	54286	-	96548	-	126745	-	150834	-	-	268209	-	-	606980	-
122	11742	19238	30024	38017	-	54732	-	97339	-	127784	-	152071	-	-	270408	-	-	611956	-
123	11849	19414	30298	38364	-	55231	-	98227	-	128950	-	153458	-	-	272875	-	-	617540	-
124	11956	19590	30572	38712	-	55731	-	99117	-	130118	-	154848	-	-	275347	-	-	623133	-
125	12064	19766	30847	39060	-	56232	-	100008	-	131288	-	156241	-	-	277823	-	-	628737	-
126	12183	19962	31153	39448	-	56790	-	101000	-	132590	-	157790	-	-	280578	-	-	634972	-
127	12291	20139	31429	39797	-	57293	-	101895	-	133765	-	159189	-	-	283065	-	-	640600	-
128	12399	20316	31706	40147	-	57798	-	102792	-	134942	-	160590	-	-	285556	-	-	646238	-
129	12508	20493	31983	40498	-	58303	-	103690	-	136122	-	161993	-	-	288052	-	-	-	-

Capacities certified by the national board of boiler and pressure vessel inspectors in accordance with the ASME boiler and pressure vessel code. Section I, power boilers.

For superheated steam, multiply the saturated steam capacities by superheat correction factor K_{sh} , pages 62-63. Capacities for the HCI-R valves: valves adjust to a minimum of 30% of full rated capacity. Restricted capacity = (% of restricted lift) x ASME rated capacity.

Capacity formula: capacity is calculated by converting valve set pressure in barg or kPag psig, calculating in pounds per hour by ASME Section I capacity formula, and converting to kilograms per hour.

CROSBY H-SERIES

SATURATED STEAM CAPACITIES

STYLES HE, HCI AND HSJ - METRIC UNITS - SATURATED STEAM CAPACITIES

Kilograms per hour at 3% overpressure

SATURATED STEAM CAPACITIES - SET PRESSURES 130-172 barg

HE HCI HSJ Set	Orifice designation and area (sq. mm)																		
	Orifice (sq. mm)																		
pres. barg	F	G	H	H2	J	J2	K	K2	L	L2	M	M2	N	P	P2	Q	Q2	R	RR
	198.1	324.5	506.5	641.3	830.0	923.2	1187.1	1641.9	1840.6	2155.5	2322.6	2565.2	2800.6	4116.1	4561.3	7125.8	7903.2	10322.6	12445.1
130	12616	20671	32260	40850	-	58809	-	104590	-	137303	-	163399	-	-	290551	-	-	-	-
131	12725	20849	32538	41202	-	59315	-	105492	-	138486	-	164807	-	-	293056	-	-	-	-
132	12834	21028	32817	41555	-	59823	-	106395	-	139672	-	166218	-	-	295564	-	-	-	-
133	12943	21207	33096	41908	-	60332	-	107299	-	140859	-	167631	-	-	298077	-	-	-	-
134	13053	21386	33375	42262	-	60841	-	108205	-	142049	-	169047	-	-	300594	-	-	-	-
135	13162	21565	33656	42616	-	61352	-	109113	-	143240	-	170465	-	-	303115	-	-	-	-
136	13272	21745	33936	42971	-	61863	-	110022	-	144434	-	171885	-	-	305641	-	-	-	-
137	13395	21946	34250	43369	-	62436	80280	111040	-	145771	157071	173476	-	-	308470	-	-	-	-
138	13505	22127	34532	43725	-	62949	80941	111953	-	146969	158363	174903	-	-	311007	-	-	-	-
139	13615	22307	34814	44083	-	63463	81602	112868	-	148170	159656	176332	-	-	313548	-	-	-	-
140	13725	22489	35096	44441	-	63978	82264	113785	-	149373	160953	177763	-	-	316093	-	-	-	-
141	13836	22670	35379	44799	-	64494	82928	114702	-	150578	162251	179197	-	-	318643	-	-	-	-
142	13961	22874	35697	45202	-	65074	83673	115733	-	151931	163709	180807	-	-	321506	-	-	-	-
143	14072	23056	35982	45562	-	65593	84340	116655	-	153141	165013	182248	-	-	324067	-	-	-	-
144	14183	23238	36267	45922	-	66112	85007	117578	-	154353	166319	183690	-	-	326632	-	-	-	-
145	14295	23421	36552	46284	-	66631	85676	118503	-	155567	167627	185135	-	-	329201	-	-	-	-
146	14420	23627	36873	46690	-	67217	86428	119544	-	156933	169099	186761	-	-	332093	-	-	-	-
147	14532	23810	37159	47053	-	67739	87100	120472	-	158153	170413	188212	-	-	334673	-	-	-	-
148	14645	23994	37446	47416	-	68262	87772	121403	-	159374	171729	189665	-	-	337257	-	-	-	-
149	14771	24201	37770	47826	-	68852	88531	122451	-	160751	173212	191303	-	-	340170	-	-	-	-
150	14884	24386	38058	48191	-	69377	89206	123386	-	161977	174534	192763	-	-	342766	-	-	-	-
151	14997	24571	38347	48556	-	69903	89883	124322	-	163206	175858	194225	-	-	345365	-	-	-	-
152	15124	24780	38672	48969	-	70497	90646	125378	-	164593	177352	195876	-	-	348300	-	-	-	-
153	15238	24966	38962	49336	-	71026	91326	126318	-	165826	178681	197344	-	-	350910	-	-	-	-
154	15351	25152	39253	49703	-	71555	92006	127259	-	167062	180013	198814	-	-	353525	-	-	-	-
155	15479	25362	39581	50119	-	72153	92776	128323	-	168459	181518	200477	-	-	356482	-	-	-	-
156	15593	25549	39873	50488	-	72685	93459	129268	-	169700	182855	201953	-	-	359107	-	-	-	-
157	15722	25760	40202	50906	-	73286	94232	130338	-	171104	184369	203625	-	-	362079	-	-	-	-
158	15837	25948	40495	51277	-	73820	94919	131287	-	172350	185711	205107	-	-	364715	-	-	-	-
159	15966	26160	40827	51697	-	74425	95696	132362	-	173762	187232	206787	-	-	367703	-	-	-	-
160	16082	26349	41121	52069	-	74960	96385	133315	-	175012	188580	208276	-	-	370350	-	-	-	-
161	16212	26562	41454	52491	-	75568	97166	134396	-	176431	190108	209964	-	-	373352	-	-	-	-
162	16342	26776	41789	52914	-	76177	97950	135480	-	177854	191642	211658	-	-	376363	-	-	-	-
163	16458	26966	42084	53289	-	76717	98644	136439	-	179113	192999	213156	-	-	379028	-	-	-	-
164	16590	27181	42420	53714	-	77329	99431	137528	-	180543	194539	214858	-	-	382054	-	-	-	-
165	16706	27372	42717	54090	-	77871	100127	138491	-	181808	195902	216362	-	-	384729	-	-	-	-
166	16838	27588	43055	54518	-	78486	100919	139586	-	183245	197450	218073	-	-	387770	-	-	-	-
167	16970	27805	43393	54947	-	79104	101713	140684	-	184686	199003	219788	-	-	390820	-	-	-	-
168	17103	28022	43733	55377	-	79722	102509	141785	-	186131	200560	221508	-	-	393879	-	-	-	-
169	17220	28215	44033	55756	-	80269	103211	142757	-	187407	201935	223026	-	-	396578	-	-	-	-
170	17354	28433	44374	56188	-	80891	104011	143863	-	188860	203500	224755	-	-	399652	-	-	-	-
171	17488	28653	44716	56622	-	81515	104813	144973	-	190316	205070	226488	-	-	402734	-	-	-	-
172	17622	28873	45059	57056	-	82141	105618	146086	-	191777	206644	228226	-	-	405825	-	-	-	-

Capacities certified by the national board of boiler and pressure vessel inspectors in accordance with the ASME boiler and pressure vessel code. Section I, power boilers.

For superheated steam, multiply the saturated steam capacities by superheat correction factor K_{sh} , pages 62-63. Capacities for the HCI-R valves: valves adjust to a minimum of 30% of full rated capacity. Restricted capacity = (% of restricted lift) x ASME rated capacity.

Capacity formula: capacity is calculated by converting valve set pressure in barg or kPag psig, calculating in pounds per hour by ASME Section I capacity formula, and converting to kilograms per hour.

CROSBY H-SERIES

SATURATED STEAM CAPACITIES

STYLES HE, HCI AND HSJ - METRIC UNITS - SATURATED STEAM CAPACITIES

Kilograms per hour at 3% overpressure

SATURATED STEAM CAPACITIES - SET PRESSURES 173-213 barg

		Orifice designation and area (sq. mm)																	
HE																			
HCI																			
HSJ																			
Set	Orifice (sq. mm)																		
pres.	F	G	H	H2	J	J2	K	K2	L	L2	M	M2	N	P	P2	Q	Q2	R	RR
barg	198.1	324.5	506.5	641.3	830.0	923.2	1187.1	1641.9	1840.6	2155.5	2322.6	2565.2	2800.6	4116.1	4561.3	7125.8	7903.2	10322.6	12445.1
173	17756	29093	45404	57492	-	82768	106425	147202	-	193242	208222	229970	-	-	408925	-	-	-	-
174	17875	29287	45707	57876	-	83320	107135	148184	-	194531	209612	231505	-	-	411655	-	-	-	-
175	18010	29509	46053	58314	-	83951	107945	149305	-	196004	211198	233257	-	-	414770	-	-	-	-
176	18146	29731	46400	58753	-	84583	108758	150430	-	197480	212788	235013	-	-	417893	-	-	-	-
177	18282	29954	46747	59193	-	85217	109574	151557	-	198960	214384	236775	-	-	421026	-	-	-	-
178	18418	30178	47096	59635	-	85853	110391	152688	-	200444	215983	238541	-	-	424166	-	-	-	-
179	18555	30402	47446	60078	-	86491	111211	153822	-	201933	217586	240312	-	-	427316	-	-	-	-
180	18692	30626	47796	60522	-	87130	112033	154958	-	203425	219195	242089	-	-	430475	-	-	-	-
181	18830	30852	48148	60967	-	87771	112857	156098	-	204922	220807	243869	-	-	433642	-	-	-	-
182	18968	31077	48501	61414	-	88414	113683	157242	-	206422	222424	245656	-	-	436817	-	-	-	-
183	19123	31332	48899	61918	-	89139	114616	158531	-	208115	224249	247671	-	-	440400	-	-	-	-
184	19262	31560	49253	62367	-	89785	115447	159682	-	209625	225876	249467	-	-	443595	-	-	-	-
185	19401	31788	49609	62817	-	90434	116281	160835	-	211139	227507	251269	-	-	446799	-	-	-	-
186	19541	32016	-	63269	-	91084	117118	161991	-	212657	229143	253076	-	-	450011	-	-	-	-
187	19698	32274	-	63779	-	91818	118061	163297	-	214372	230991	255116	-	-	453640	-	-	-	-
188	-	-	-	64233	-	92473	118903	164461	-	215899	232636	256934	-	-	456872	-	-	-	-
189	-	-	-	64689	-	93128	119746	165627	-	217430	234286	258756	-	-	460112	-	-	-	-
190	-	-	-	65204	-	93870	120700	166946	-	219162	236152	260816	-	-	463775	-	-	-	-
191	-	-	-	65662	-	94530	121548	168119	-	220702	237811	262649	-	-	467035	-	-	-	-
192	-	-	-	66180	-	95276	122508	169447	-	222444	239689	264723	-	-	470722	-	-	-	-
193	-	-	-	66642	-	95940	123361	170627	-	223994	241359	266567	-	-	474002	-	-	-	-
194	-	-	-	67163	-	96691	124326	171963	-	225748	243248	268654	-	-	477713	-	-	-	-
195	-	-	-	67627	-	97359	125185	173150	-	227307	244928	270509	-	-	481012	-	-	-	-
196	-	-	-	68152	-	98115	126157	174495	-	229071	246830	272609	-	-	484746	-	-	-	-
197	-	-	-	68679	-	98873	127132	175844	-	230842	248738	274717	-	-	488494	-	-	-	-
198	-	-	-	69208	-	99634	128111	177197	-	232619	250652	276832	-	-	492254	-	-	-	-
199	-	-	-	69677	-	100310	128980	178400	-	234198	252353	278710	-	-	495594	-	-	-	-
200	-	-	-	70209	-	101076	129966	179762	-	235986	254280	280839	-	-	499378	-	-	-	-
201	-	-	-	70743	-	101845	130953	181129	-	237781	256214	282974	-	-	503176	-	-	-	-
202	-	-	-	71279	-	102616	131945	182501	-	239581	258154	285117	-	-	506986	-	-	-	-
203	-	-	-	71816	-	103390	132940	183877	-	241388	260101	287267	-	-	510809	-	-	-	-
204	-	-	-	72356	-	104167	133939	185258	-	243201	262054	289425	-	-	514646	-	-	-	-
205	-	-	-	72897	-	104945	134941	186643	-	245020	264014	291589	-	-	518495	-	-	-	-
206	-	-	-	73503	-	105818	136062	188195	-	247057	266209	294014	-	-	522806	-	-	-	-
207	-	-	-	74049	-	106603	137072	189591	-	248889	268184	296194	-	-	526683	-	-	-	-
208	-	-	-	74595	-	107390	138084	190991	-	250728	270165	298382	-	-	530574	-	-	-	-
209	-	-	-	75208	-	108272	139218	192560	-	252787	272384	300833	-	-	534932	-	-	-	-
210	-	-	-	75759	-	109065	140238	193971	-	254639	274379	303036	-	-	538850	-	-	-	-
211	-	-	-	76376	-	109954	141381	195551	-	256714	276615	305506	-	-	543241	-	-	-	-
212	-	-	-	76931	-	110753	142408	196972	-	258579	278625	307726	-	-	547188	-	-	-	-
213	-	-	-	77553	-	111649	143559	198564	-	260670	280877	310213	-	-	551611	-	-	-	-
214	-	-	-	78178	-	112547	-	200163	-	262768	-	312710	-	-	556052	-	-	-	-

Capacities certified by the national board of boiler and pressure vessel inspectors in accordance with the ASME boiler and pressure vessel code. Section I, power boilers.

For superheated steam, multiply the saturated steam capacities by superheat correction factor K_{sh} , pages 62-63. Capacities for the HCI-R valves: valves adjust to a minimum of 30% of full rated capacity.

Restricted capacity = (% of restricted lift) x ASME rated capacity.

Capacity formula: capacity is calculated by converting valve set pressure in barg or kPag psig, calculating in pounds per hour by ASME Section I capacity formula, and converting to kilograms per hour.

For steam capacities at 10% overpressure up to absolute pressure of 103.4 barg, multiply the capacity from above table by ratio $1.10p + 1.014$ where p is set pressure (barg) $1.03p + 1.014$

CROSBY H-SERIES

SATURATED STEAM CAPACITIES

STYLE HSL - USCS (UNITED STATES CUSTOMARY SYSTEM) UNITS - SATURATED STEAM CAPACITIES*

Pounds per hour at 3% overpressure

SET PRESSURES 15 - 725 PSIG

Set pressure (psig)	Orifice area (sq in)									
	F 0.339	G 0.553	H 0.868	J 1.327	K 2.046	L 3.167	M 3.955	N 4.831	P 7.031	QQ 11.045
15	480	784	1231	1882	2902	4492	5610	6853	9974	15669
20	556	908	1425	2179	3360	5201	6495	7934	11548	18140
30	708	1155	1814	2773	4276	6618	8265	10096	14694	23083
40	860	1403	2202	3367	5191	8036	10035	12258	17841	28026
50	1011	1650	2591	3961	6107	9453	11805	14420	20987	32969
60	1163	1898	2979	4555	7023	10871	13575	16582	24134	37912
70	1316	2148	3371	5154	7947	12302	15363	18766	27312	42905
80	1473	2403	3771	5766	8891	13762	17186	20993	30553	47996
90	1629	2658	4172	6378	9834	15222	19009	23220	33794	53088
100	1785	2912	4572	6989	10777	16682	20832	25447	37035	58179
110	1941	3167	4972	7601	11720	18141	22656	27674	40276	63270
120	2098	3422	5372	8213	12663	19601	24479	29901	43517	68362
130	2254	3677	5772	8825	13606	21061	26302	32127	46758	73453
140	2410	3932	6172	9436	14549	22521	28125	34354	49999	78544
150	2567	4187	6572	10048	15492	23981	29948	36581	53240	83635
160	2723	4442	6972	10660	16436	25441	31771	38808	56481	88727
170	2879	4697	7372	11271	17379	26901	33594	41035	59722	93818
180	3035	4952	7773	11883	18322	28361	35417	43262	62963	98909
190	3192	5207	8173	12495	19265	29820	37240	45489	66204	104001
200	3348	5462	8573	13106	20208	31280	39063	47716	69445	109092
210	3504	5716	8973	13718	21151	32740	40887	49943	72686	114183
220	3660	5971	9373	14330	22094	34200	42710	52170	75927	119275
230	3817	6226	9773	14941	23037	35660	44533	54396	79168	124366
240	3973	6481	10173	15553	23981	37120	46356	56623	82409	129457
250	4129	6736	10573	16165	24924	38580	48179	58850	85650	134549
260	4285	6991	10974	16777	25867	40039	50002	61077	88891	139640
270	4442	7246	11374	17388	26810	41499	51825	63304	92132	144731
280	4598	7501	11774	18000	27753	42959	53648	65531	95374	149823
290	4754	7756	12174	18612	28696	44419	55471	67758	98615	154914
300	4910	8011	12574	19223	29639	45879	57294	69985	101856	160005
310	5067	8266	12974	19835	30582	47339	59118	72212	105097	165097
320	5223	8520	13374	20447	31526	48799	60941	74439	108338	170188
330	5379	8775	13774	21058	32469	50258	62764	76665	111579	175279
340	5536	9030	14174	21670	33412	51718	64587	78892	114820	180370
350	5692	9285	14575	22282	34355	53178	66410	81119	118061	185462
360	5848	9540	14975	22894	35298	54638	68233	83346	121302	190553
370	6004	9795	15375	23505	36241	56098	70056	85573	124543	195644
380	6161	10050	15775	24117	37184	57558	71879	87800	127784	200736
390	6317	10305	16175	24729	38127	59018	73702	90027	131025	205827

NOTES

- For steam capacities at 10% overpressure, multiply the capacity from the above table by the ratio $\frac{1.10p + 14.7}{1.03p + 14.7}$ where 'p' is set pressure (psig).
- For superheated steam, multiply the saturated steam capacities by Superheat correction factor K_{sh} on pages 60-61.

* Capacities certified by the national board and pressure vessel inspectors in accordance with the ASME boiler and pressure vessel code. Section I power boilers.

Capacity formula:

$$W = (51.5 \times AP \times K)$$

where:

- W Rated capacity, lbs/hr.
- P $(1.03 \times \text{set pressure}) + 14.7 = \text{absolute pressure, psia}$
- K 0.869 = average coefficient of discharge
- A Nozzle throat (orifice) area, sq. in.

CROSBY H-SERIES

STYLE HSL

STYLE HSL - USCS (UNITED STATES CUSTOMARY SYSTEM) UNITS - SATURATED STEAM CAPACITIES*

Pounds per hour at 3% overpressure

SET PRESSURES 15 - 725 psig (continued)

Set pressure (psig)	Orifice area (sq in)									
	F 0.339	G 0.553	H 0.868	J 1.327	K 2.046	L 3.167	M 3.955	N 4.831	P 7.031	QQ 11.045
400	6473	10560	16575	25340	39071	60478	75525	92254	134266	210918
410	6629	10815	16975	25952	40014	61937	77349	94481	137507	216010
420	6786	11070	17375	26564	40957	63397	79172	96708	140748	221101
430	6942	11324	17775	27175	41900	64857	80995	98935	143989	226192
440	7098	11579	18176	27787	42843	66317	82818	101161	147230	231284
450	7254	11834	18576	28399	43786	67777	84641	103388	150471	236375
460	7411	12089	18976	29010	44729	69237	86464	105615	153712	241466
470	7567	12344	19376	29622	45672	70697	88287	107842	156953	246558
480	7723	12599	19776	30234	46616	72156	90110	110069	160194	251649
490	7880	12854	20176	30846	47559	73616	91933	112296	163435	256740
500	8036	13109	20576	31457	48502	75076	93756	114523	166676	261831
510	8192	13364	20976	32069	49445	76536	95580	116750	169917	266923
520	8348	13619	21376	32681	50388	77996	97403	118977	173158	272014
530	8505	13874	21777	33292	51331	79456	99226	121204	176399	277105
540	8661	14129	22177	33904	52274	80916	101049	123430	179640	282197
550	8817	14383	22577	34516	53217	82375	102872	125657	182881	287288
560	8973	14638	22977	35127	54161	83835	104695	127884	186122	292379
570	9130	14893	23377	35739	55104	85295	106518	130111	189363	297471
580	9286	15148	23777	36351	56047	86755	108341	132338	192604	302562
590	9442	15403	24177	36963	56990	88215	110164	134565	195845	307653
600	9598	15658	24577	37574	57933	89675	111987	136792	199086	312745
610	9755	15913	24978	38186	58876	91135	113811	139019	202327	317836
620	9911	16168	25378	38798	59819	92595	115634	141246	205568	322927
630	10067	16423	25778	39409	60762	94054	117457	143473	208809	328019
640	10224	16678	26178	40021	61706	95514	119280	145699	212050	333110
650	10380	16933	26578	40633	62649	96974	121103	147926	215291	338201
660	10536	17187	26978	41244	63592	98434	122926	150153	218532	343293
670	10692	17442	27378	41856	64535	99894	124749	152380	221773	348384
680	10849	17697	27778	42468	65478	101354	126572	154607	225014	353475
690	11005	17952	28178	43079	66421	102814	128395	156834	228255	358566
700	11161	18207	28579	43691	67364	104273	130218	159061	231496	363658
710	11317	18462	28979	44303	68307	105733	132042	161288	234737	368749
720	11474	18717	29379	44915	69251	107193	133865	163515	237978	373840
725	11552	18844	29579	45220	69722	107923	134776	164628	239599	376386

* Capacities certified by the national board and pressure vessel inspectors in accordance with the ASME boiler and pressure vessel code, Section I power boilers

Capacity formula:

$$W = (51.5 \times AP \times K)$$

where:

W Rated capacity, lbs/hr.

P $(1.03 \times \text{set pressure}) + 14.7 =$ absolute pressure, psia

K 0.869 = average coefficient of discharge

A Nozzle throat (orifice) area, sq. in.

CROSBY H-SERIES

SATURATED STEAM CAPACITIES

STYLE HSL - METRIC UNITS - SATURATED STEAM CAPACITIES

Kilograms per hour at 3% overpressure

SET PRESSURES 1.034 - 50 barg

Set pressure (barg)	Orifice area (sq mm)									
	F (218.7)	G (356.8)	H (560.0)	J (856.1)	K (1320.0)	L (2043.2)	M (2551.6)	N (3116.8)	P (4536.1)	QQ (7125.8)
1.034	218	356	558	854	1316	2038	2545	3108	4524	7106
2	314	513	805	1231	1898	2938	3670	4482	6524	10248
3	414	676	1060	1622	2501	3871	4834	5904	8594	13500
4	514	839	1316	2013	3103	4803	5998	7327	10664	16752
5	615	1003	1575	2408	3713	5747	7177	8767	12759	20043
6	718	1171	1838	2810	4333	6707	8376	10232	14891	23393
7	821	1339	2101	3213	4954	7668	9576	11697	17023	26742
8	924	1506	2365	3615	5574	8628	10775	13161	19156	30091
9	1026	1674	2628	4017	6195	9588	11974	14627	21288	33441
10	1129	1842	2891	4420	6815	10549	13174	16092	23420	36790
11	1232	2009	3154	4823	7435	11509	14373	17557	25552	40140
12	1334	2177	3417	5225	8056	12470	15573	19022	27684	43490
13	1437	2345	3681	5627	8676	13430	16772	20487	29816	46839
14	1540	2512	3944	6030	9297	14391	17971	21952	31949	50188
15	1643	2680	4207	6432	9917	15351	19171	23417	34081	53538
16	1746	2848	4471	6835	10538	16312	20370	24882	36213	56887
17	1848	3016	4734	7237	11158	17272	21570	26347	38345	60237
18	1951	3183	4997	7639	11779	18232	22769	27812	40478	63586
19	2054	3351	5260	8042	12399	19193	23968	29277	42610	66936
20	2157	3519	5523	8444	13019	20153	25168	30742	44742	70285
21	2260	3686	5786	8846	13640	21113	26367	32207	46874	73635
22	2363	3854	6050	9249	14260	22074	27566	33672	49006	76984
23	2465	4022	6313	9652	14881	23034	28766	35137	51138	80333
24	2568	4190	6576	10054	15502	23995	29965	36602	53271	83683
25	2671	4357	6839	10456	16122	24955	31165	38067	55403	87033
26	2774	4525	7103	10859	16743	25916	32364	39532	57535	90382
27	2877	4693	7366	11261	17363	26876	33563	40997	59667	93732
28	2980	4860	7629	11664	17983	27837	34763	42462	61800	97081
29	3082	5028	7893	12066	18604	28797	35962	43927	63932	100430
30	3185	5196	8156	12468	19224	29757	37161	45392	66064	103780
31	3288	5364	8419	12871	19845	30718	38361	46857	68196	107129
32	3391	5531	8682	13273	20465	31678	39560	48323	70328	110479
33	3494	5699	8945	13676	21086	32639	40759	49788	72460	113829
34	3596	5867	9208	14078	21706	33599	41959	51253	74593	117178
35	3699	6034	9472	14480	22327	34559	43158	52717	76725	120527
36	3802	6202	9735	14883	22947	35520	44358	54183	78857	123877
37	3905	6370	9998	15285	23567	36480	45557	55648	80989	127226
38	4007	6538	10262	15688	24188	37440	46756	57113	83122	130576
39	4110	6705	10525	16090	24808	38401	47956	58578	85254	133925
40	4213	6873	10788	16493	25429	39361	49155	60043	87386	137275

NOTES

- For steam capacities at 10% overpressure, multiply the capacity from the above table by the ratio $\frac{1.10p + 14.7}{1.03p + 14.7}$ where 'p' is set pressure (psig).
- For superheated steam, multiply the saturated steam capacities by Superheat correction factor K_{sh} on pages 62-63.

Capacity formula

Capacity is calculated by converting valve set pressure in barg to psig, calculating in pounds per hour by ASME Section I Capacity formula, and converting to kilograms per hour.

CROSBY H-SERIES

SATURATED STEAM CAPACITIES

STYLE HSL - METRIC UNITS - SATURATED STEAM CAPACITIES

Kilograms per hour at 3% overpressure

SET PRESSURES 1.034 - 50 barg (continued)

Set pressure (barg)	Orifice area (sq mm)									
	F (218.7)	G (356.8)	H (560.0)	J (856.1)	K (1320.0)	L (2043.2)	M (2551.6)	N (3116.8)	P (4536.1)	QQ (7125.8)
41	4316	7041	11051	16895	26049	40322	50355	61508	89518	140624
42	4419	7208	11314	17297	26670	41282	51554	62973	91650	143974
43	4521	7376	11577	17700	27290	42243	52753	64438	93782	147323
44	4624	7544	11841	18102	27911	43203	53953	65903	95915	150672
45	4727	7712	12104	18505	28531	44164	55152	67368	98047	154022
46	4830	7879	12367	18907	29151	45124	56352	68833	100179	157372
47	4933	8047	12630	19309	29772	46085	57551	70298	102311	160721
48	5035	8215	12894	19712	30393	47045	58750	71763	104444	164070
49	5138	8382	13157	20115	31013	48005	59949	73228	106576	167420
50	5241	8550	13420	20517	31634	48966	61149	74693	108708	170769

NOTES

- For steam capacities at 10% overpressure, multiply the capacity from the above table by the ratio $\frac{1.10p + 14.7}{1.03p + 14.7}$ where 'p' is set pressure (psig).
- For superheated steam, multiply the saturated steam capacities by Superheat correction factor K_{sh} on pages 62-63.

Capacity formula

Capacity is calculated by converting valve set pressure in barg to psig, calculating in pounds per hour by ASME Section I Capacity formula, and converting to kilograms per hour.

CROSBY H-SERIES

SUPERHEAT CORRECTION FACTOR

Superheat correction factor -K_{sh}

Flowing* pressure psia (bara)	Total temperature superheated steam															
	400°F (204°C)	450°F (232°C)	500°F (260°C)	550°F (288°C)	600°F (316°C)	650°F (343°C)	700°F (371°C)	750°F (399°C)	800°F (427°C)	850°F (454°C)	900°F (482°C)	950°F (510°C)	1000°F (538°C)	1050°F (566°C)	1100°F (593°C)	
50	[3.4]	.987	.957	.930	.905	.882	.861	.841	.823	.805	.789	.774	.759	.745	.732	.719
100	[6.9]	.998	.963	.935	.909	.885	.864	.843	.825	.807	.790	.775	.760	.746	.733	.720
150	[10.3]	.984	.970	.940	.913	.888	.866	.846	.826	.808	.792	.776	.761	.747	.733	.721
200	[13.8]	.979	.977	.945	.917	.892	.869	.848	.828	.810	.793	.777	.762	.748	.734	.721
250	[17.2]		.972	.951	.921	.895	.871	.850	.830	.812	.794	.778	.763	.749	.735	.722
300	[20.7]		.968	.957	.926	.898	.874	.852	.832	.813	.796	.780	.764	.750	.736	.723
350	[24.1]		.968	.963	.930	.902	.877	.854	.834	.815	.797	.781	.765	.750	.736	.723
400	[27.6]			.963	.935	.906	.880	.857	.836	.816	.798	.782	.766	.751	.737	.724
450	[31.0]			.961	.940	.909	.883	.859	.838	.818	.800	.783	.767	.752	.738	.725
500	[34.5]			.961	.946	.914	.886	.862	.840	.820	.801	.784	.768	.753	.739	.725
550	[37.9]			.962	.952	.918	.889	.864	.842	.822	.803	.785	.769	.754	.740	.726
600	[41.4]			.964	.958	.922	.892	.867	.844	.823	.804	.787	.770	.755	.740	.727
650	[44.8]			.968	.958	.927	.896	.869	.846	.825	.806	.788	.771	.756	.741	.728
700	[48.3]				.958	.931	.899	.872	.848	.827	.807	.789	.772	.757	.742	.728
750	[51.7]				.958	.936	.903	.875	.850	.828	.809	.790	.774	.758	.743	.729
800	[55.2]				.960	.942	.906	.878	.852	.830	.810	.792	.774	.759	.744	.730
850	[58.6]				.962	.947	.910	.880	.855	.832	.812	.793	.776	.760	.744	.730
900	[62.1]				.965	.953	.914	.883	.857	.834	.813	.794	.777	.760	.745	.731
950	[65.5]				.969	.958	.918	.886	.860	.836	.815	.796	.778	.761	.746	.732
1000	[69.0]				.974	.959	.923	.890	.862	.838	.816	.797	.779	.762	.747	.732
1050	[72.4]					.960	.927	.893	.864	.840	.818	.798	.780	.763	.748	.733
1100	[75.8]					.962	.931	.896	.867	.842	.820	.800	.781	.764	.749	.734
1150	[79.3]					.964	.936	.899	.870	.844	.821	.801	.782	.765	.749	.735
1200	[82.7]					.966	.941	.903	.872	.846	.823	.802	.784	.766	.750	.735
1250	[86.2]					.969	.946	.906	.875	.848	.825	.804	.785	.767	.751	.736
1300	[89.6]					.973	.952	.910	.878	.850	.826	.805	.786	.768	.752	.737
1350	[93.1]					.977	.958	.914	.880	.852	.828	.807	.787	.769	.753	.737
1400	[96.5]					.982	.963	.918	.883	.854	.830	.808	.788	.770	.754	.738
1450	[100.0]					.987	.968	.922	.886	.857	.832	.809	.790	.771	.754	.739
1500	[103.4]					.993	.970	.926	.889	.859	.833	.811	.791	.772	.755	.740
1550	[106.9]						.972	.930	.892	.861	.835	.812	.792	.773	.756	.740
1600	[110.3]						.973	.934	.894	.863	.836	.813	.792	.774	.756	.740
1650	[113.8]						.973	.936	.895	.863	.836	.812	.791	.772	.755	.739
1700	[117.2]						.973	.938	.895	.863	.835	.811	.790	.771	.754	.738
1750	[120.7]						.974	.940	.896	.862	.835	.810	.789	.770	.752	.736
1800	[124.1]						.975	.942	.897	.862	.834	.810	.788	.768	.751	.735
1850	[127.6]						.976	.944	.897	.862	.833	.809	.787	.767	.749	.733
1900	[131.0]						.977	.946	.898	.862	.832	.807	.785	.766	.748	.731
1950	[134.5]						.979	.949	.898	.861	.832	.806	.784	.764	.746	.729
2000	[137.9]						.982	.952	.899	.861	.831	.805	.782	.762	.744	.728
2050	[141.3]						.985	.954	.899	.860	.830	.804	.781	.761	.742	.726
2100	[144.8]						.988	.956	.900	.860	.828	.802	.779	.759	.740	.724

* Flowing pressure is the valve set pressure plus the overpressure plus the atmospheric pressure 14.7 psia (1.014 bara).

For superheated steam, multiply the saturated steam capacity by correction factor - K_{sh} ASME Section III, division I - appendices Table XVIII-1110-1.

CROSBY H-SERIES

SUPERHEAT CORRECTION FACTOR

Superheat correction factor - K_{sh}

Flowing* pressure	Total temperature superheated steam														
	400°F (204°C)	450°F (232°C)	500°F (260°C)	550°F (288°C)	600°F (316°C)	650°F (343°C)	700°F (371°C)	750°F (399°C)	800°F (427°C)	850°F (454°C)	900°F (482°C)	950°F (510°C)	1000°F (538°C)	1050°F (566°C)	1100°F (593°C)
2150 (148.2)						.956	.900	.859	.827	.801	.778	.757	.738	.722	
2200 (151.7)						.955	.901	.859	.826	.799	.776	.755	.736	.720	
2250 (155.1)						.954	.901	.858	.825	.797	.774	.753	.734	.717	
2300 (158.6)						.953	.901	.857	.823	.795	.772	.751	.732	.725	
2350 (162.0)						.952	.902	.856	.822	.794	.769	.748	.729	.712	
2400 (165.5)						.952	.902	.855	.820	.791	.767	.746	.727	.710	
2450 (168.9)						.951	.902	.854	.818	.789	.765	.743	.724	.707	
2500 (172.4)						.951	.902	.852	.816	.787	.762	.740	.721	.704	
2550 (175.8)						.951	.902	.851	.814	.784	.759	.738	.718	.701	
2600 (179.3)						.951	.903	.849	.812	.782	.756	.735	.715	.698	
2650 (182.7)						.952	.903	.848	.809	.779	.754	.731	.712	.695	
2700 (186.2)						.952	.903	.846	.807	.776	.750	.728	.708	.691	
2750 (189.6)						.953	.903	.844	.804	.773	.747	.724	.705	.687	
2800 (193.1)						.956	.903	.842	.801	.769	.743	.721	.701	.684	
2850 (196.5)						.959	.902	.839	.798	.766	.739	.717	.697	.679	
2900 (200.0)						.963	.902	.836	.794	.762	.735	.713	.693	.675	
2950 (203.4)							.902	.834	.790	.758	.731	.708	.688	.671	
3000 (206.9)							.899	.831	.786	.753	.726	.704	.684	.666	
3050 (210.3)							.899	.827	.782	.749	.722	.699	.679	.661	
3100 (213.7)							.896	.823	.777	.744	.716	.693	.673	.656	
3150 (217.2)							.894	.819	.772	.738	.711	.688	.668	.650	
3200 (220.6)							.889	.815	.767	.733	.705	.682	.662	.644	

* Flowing pressure is the valve set pressure plus the overpressure plus the atmospheric pressure 14.7 psia (1.014 bara).

For superheated steam, multiply the saturated steam capacity by correction factor - K_{sh} ASME Section III, division I - appendices Table XVIII-1110-1.

CROSBY H-SERIES

STYLE HCA-I STEAM CAPACITIES - USCS (UNITED STATES CUSTOMARY SYSTEM) UNITS

STEAM CAPACITY (lb/hr) - K - ORIFICE (1840 in²)

Pounds per hour at 3% overpressure

Set pressure, psig	Steam relieving temperature, T - (°F)							
	750	800	850	900	950	1000	1050	1100
3100.5	282669	259180	243699	232755	223946	216473	210333	204728
3100.5	282669	259180	243699	232755	223946	216473	210333	204728
3150	288788	264655	248656	236996	228048	220455	213676	207982
3200	295004	270214	253412	241292	231927	224214	217603	211543
3250	301831	275816	258193	245884	236094	227982	221268	215114
3300	308442	281745	263000	250503	240562	232042	224941	218693
3350	315402	287725	268120	254859	244480	235831	228623	222280
3400	322723	293757	272983	259232	248698	239921	232314	225877
3450	330121	299840	277871	263918	252934	243731	236012	229481
3500	337897	305974	283388	268330	257187	247851	239720	233095
3550	346370	312466	288336	273064	261457	251683	243742	236716
3600	354945	319017	293620	277514	265744	255833	247471	240037
3650	364252	325629	298938	282295	270049	259686	251208	243672
3700	374633	332618	304290	287102	274370	263866	255272	247633
3750	385805	339354	309677	291935	278386	268064	259031	251290
3800	398121	346803	315097	296466	282738	271951	262799	254954
3850	410956	353999	320552	301346	287106	276178	266575	258627
3900	425666	361262	326377	306251	291492	280087	270695	262309
3950	441635	368935	331905	310843	295895	284345	274493	266000
4000	458557	376684	337467	315795	300315	288275	278299	269699
4050	480986	384859	343412	320774	304752	292562	282113	273406
4100	504885	392766	349400	325777	309559	296866	286289	277122
4150	528507	400751	355430	330807	314035	301188	290125	280847
4200	552187	409175	361504	335863	318889	305165	293970	284580
4250	-	418049	367620	341309	323403	309517	297823	288322
4300	-	427387	373779	346420	327935	313516	302055	292072
4350	-	436828	380355	351557	332483	317897	305929	295831
4400	-	446372	386604	356720	337427	322296	309813	299599
4450	-	456784	392896	362290	342014	326329	313704	303375
4500	-	466929	399617	367509	346619	330758	317992	307160
4550	-	477186	405999	372753	351240	335203	321905	310953
4600	-	488345	412819	378418	355879	339271	325827	314755
4650	-	499232	420090	383717	360934	343747	330157	318565
4700	-	511048	427018	389043	365611	348240	334100	322384
4750	-	522592	433996	394802	370714	352341	338052	326212
4800	-	535090	441439	400596	375429	356864	342425	330048
4850	-	547317	448525	406423	380579	361404	346398	333892
4900	-	560102	456083	412286	385333	365961	350379	338167
4950	-	573033	463701	417757	390530	370536	354795	342033
5000	-	586539	471380	423683	395753	375127	359228	345907
5050	-	599766	479118	429644	400567	379736	363244	-
5100	-	613138	486916	435639	405836	384361	-	-
5150	-	627098	495217	442111	410689	389004	-	-
5200	-	640766	503140	447732	416006	-	-	-
5250	-	654579	512024	453829	-	-	-	-
5300	-	668538	520075	-	-	-	-	-
5350	-	682183	-	-	-	-	-	-

NOTES

Capacities certified by the National Board of Boiler and Pressure Vessel Inspectors and in accordance with the ASME Boiler and Pressure Vessel Code, Section I.

CROSBY H-SERIES

STYLE HCA-I STEAM CAPACITIES - USCS (UNITED STATES CUSTOMARY SYSTEM) UNITS

STEAM CAPACITY (lb/hr) - K2 - ORIFICE (2545 in²)

Pounds per hour at 3% overpressure

Set pressure, psig	Steam relieving temperature, T - (°F)							
	750	800	850	900	950	1000	1050	1100
3100.5	390974	358486	337072	321935	309752	299415	290923	283170
3150	399438	366058	343929	327802	315425	304923	295547	287670
3200	408036	373747	350507	333743	320790	310122	300979	292597
3250	417478	381496	357120	340096	326554	315333	306048	297535
3300	426623	389696	363769	346484	332734	320949	311128	302486
3350	436249	397968	370852	352508	338153	326190	316221	307448
3400	446375	406310	377577	358557	343988	331847	321325	312422
3450	456607	414724	384339	365040	349847	337117	326441	317408
3500	467363	423209	391969	371141	355729	342816	331569	322405
3550	479082	432188	398813	377689	361635	348116	337132	327415
3600	490944	441250	406121	383844	367565	353856	342290	332008
3650	503816	450394	413477	390457	373519	359186	347459	337035
3700	518175	460062	420880	397106	379496	364968	353081	342515
3750	533628	469378	428330	403790	385051	370773	358280	347572
3800	550662	479682	435828	410058	391070	376150	363491	352641
3850	568415	489634	443373	416807	397112	381997	368714	357721
3900	58761	499681	451430	423592	403178	387404	374413	362814
3950	610848	510293	459076	429943	409268	393292	379665	367918
4000	634254	521011	466769	436793	415382	398728	384930	373035
4050	665278	532318	474992	443679	421519	404658	390206	378163
4100	698333	543256	483273	450600	428168	410612	395982	383303
4150	731005	554300	491615	457557	434358	416589	401288	388454
4200	763759	565951	500015	464549	441072	422090	406605	393618
4250	-	578226	508475	472083	447316	428109	411935	398794
4300	-	591142	516993	479152	453584	433640	417788	403981
4350	-	604200	526089	486257	459875	439701	423147	409180
4400	-	617401	534732	493398	466713	445784	428518	414391
4450	-	631803	543435	501103	473058	451363	433901	419614
4500	-	645835	552732	508321	479426	457488	439831	424849
4550	-	660021	561559	515574	485819	463638	445244	430095
4600	-	675455	570992	523409	492234	469263	450668	435354
4650	-	690514	581049	530740	499227	475454	456657	440624
4700	-	706857	590631	538105	505696	481668	462111	445906
4750	-	722825	600283	546071	512754	487342	467577	451201
4800	-	740111	610577	554085	519276	493598	473625	456506
4850	-	757023	620378	562146	526399	499877	479121	461824
4900	-	774707	630832	570254	532975	506180	484628	467736
4950	-	792592	641370	577821	540163	512507	490736	473084
5000	-	811273	651990	586018	547386	518858	496867	478443
5050	-	829567	662693	594263	554045	525232	502422	483814
5100	-	848063	673479	602555	561334	531630	507989	489197
5150	-	867372	684961	611506	568046	538052	514179	494592
5200	-	886277	695919	619281	575400	544498	519776	-
5250	-	905383	708208	627715	582789	550967	526008	-
5300	-	924690	719344	636827	589584	557460	-	-
5350	-	943564	731198	645362	597675	563976	-	-
5400	-	962627	743148	653944	604529	-	-	-
5450	-	981231	755840	662574	-	-	-	-
5500	-	1000014	768638	-	-	-	-	-
5550	-	1018975	-	-	-	-	-	-

NOTES

Capacities certified by the National Board of Boiler and Pressure Vessel Inspectors and in accordance with the ASME Boiler and Pressure Vessel Code, Section I.

CROSBY H-SERIES

STYLE HCA-I STEAM CAPACITIES - USCS (UNITED STATES CUSTOMARY SYSTEM) UNITS

STEAM CAPACITY (lb/hr) - M - ORIFICE (3600 in²)

Pounds per hour at 3% overpressure

Set pressure, psig	Steam relieving temperature, T - (°F)							
	750	800	850	900	950	1000	1050	1100
3100.5	553049	507092	476802	455390	438156	423534	411522	400555
3150	565021	517803	486501	463688	446181	431326	418062	406921
3200	577183	528680	495806	472093	453770	438680	425746	413890
3250	590539	539640	505160	481079	461923	446051	432916	420875
3300	603475	551240	514565	490115	470666	453995	440103	427878
3350	617091	562941	524584	498637	478330	461408	447307	434897
3400	631415	574742	534098	507193	486584	469411	454527	441933
3450	645889	586644	543662	516363	494872	476866	461764	448986
3500	661103	598646	554455	524994	503193	484927	469018	456055
3550	677681	611347	564136	534256	511547	492424	476886	463141
3600	694459	624165	574474	542963	519935	500544	484182	469638
3650	712667	637100	584879	552317	528357	508083	491495	476750
3700	732979	650775	595350	561722	536812	516261	499447	484501
3750	754837	663954	605889	571177	544669	524473	506801	491654
3800	778933	678529	616495	580043	553183	532079	514172	498824
3850	804046	692606	627168	589590	561730	540350	521560	506011
3900	832825	706818	638565	599188	570311	547997	529621	513214
3950	864068	721829	649380	608171	578925	556327	537051	520435
4000	897177	736991	660263	617861	587573	564017	544498	527672
4050	941061	752985	671894	627601	596255	572405	551962	534926
4100	987819	768457	683609	637391	605660	580826	560132	542196
4150	1034035	784079	695408	647232	614416	589281	567637	549484
4200	1080367	800560	707290	657123	623913	597063	575159	556788
4250	-	817922	719257	667779	632746	605577	582698	564109
4300	-	836193	731307	677779	641612	613401	590977	571447
4350	-	854665	744173	687830	650511	621973	598558	578801
4400	-	873338	756399	697930	660184	630579	606156	586172
4450	-	893709	768710	708829	669159	638470	613770	593560
4500	-	913558	781860	719039	678167	647135	622158	600965
4550	-	933625	794347	729299	687209	655833	629814	608387
4600	-	954558	807690	740383	696285	663791	637487	615825
4650	-	976759	821917	750752	706176	672548	645959	623280
4700	-	999877	835470	761171	715327	681339	653674	630752
4750	-	1022463	849124	772439	725310	689364	661406	638241
4800	-	1046916	863685	783774	734536	698213	669962	645746
4850	-	1070838	877549	795177	744612	707096	677735	653268
4900	-	1095852	892337	806646	753913	716012	685526	661631
4950	-	1121152	907242	817350	764081	724961	694165	669195
5000	-	1147577	922265	828946	774299	733945	702838	676776
5050	-	1173455	937405	840608	783718	742961	710696	684374
5100	-	1199618	952663	852337	794028	752012	718570	691988
5150	-	1226931	968903	864999	803523	761096	727327	699619
5200	-	1253673	984404	875997	813925	770213	735243	707267
5250	-	1280699	1001787	887928	824378	779364	744058	714932
5300	-	1308010	1017539	900816	833990	788548	752017	722613
5350	-	1334707	1034308	912889	845434	797766	760891	731211
5400	-	1361672	1051211	925029	855130	806110	768891	738934
5450	-	1387990	1069164	937236	865776	815386	777824	747590
5500	-	1414559	1087268	950435	876471	824697	785866	755356
5550	-	1441379	1104591	962785	887217	834040	794857	763138
5600	-	1468451	1122047	976143	898014	843418	802941	770936
5650	-	1494824	1140587	988635	907911	852828	811991	778752
5700	-	1520475	1159278	1002153	918799	862273	820117	786584
5750	-	1546343	1178120	1015754	929738	871751	829226	794433
5800	-	1571454	1196138	1029439	940728	882237	838369	803274
5850	-	1595783	1218223	1044191	949801	888840	843612	808215
5900	-	1619306	1239517	1058052	960874	897410	851796	816098
5950	-	1644995	1257996	1071997	971997	906997	859997	823997
6000	-	1670886	1277618	1086026	982162	917626	869224	831914
6050	-	1695962	1297390	1100138	994395	927288	877467	839847
6100	-	1721222	1318339	1114334	1005669	936984	886752	847796
6150	-	1745632	1337388	1128615	1016993	946713	896070	855763
6200	-	-	1357613	1142979	1028368	956476	904381	864788

CROSBY H-SERIES

STYLE HCA-I STEAM CAPACITIES - USCS (UNITED STATES CUSTOMARY SYSTEM) UNITS

STEAM CAPACITY (lb/hr) - M2 - ORIFICE (3976 in²)

Pounds per hour at 3% overpressure

Set pressure psig	Steam relieving temperature, T - (°F)							
	750	800	850	900	950	1000	1050	1100
3100.5	610811	560055	526601	502953	483919	467770	454504	442391
3150	624034	571885	537314	512118	492782	476375	461727	449422
3200	637466	583897	547590	521401	501164	484498	470213	457118
3250	652218	596003	557921	531325	510169	492639	478132	464834
3300	666504	608814	568308	541305	519824	501412	486069	472567
3350	681543	621737	579374	550717	528289	509600	494025	480320
3400	697363	634771	589881	560166	537405	518438	502000	488090
3450	713349	647915	600444	570294	546558	526672	509993	495880
3500	730152	661171	612364	579826	555748	535575	518004	503688
3550	748461	675199	623057	590056	564975	543855	526694	511514
3600	766991	689355	634474	599672	574240	552823	534752	518689
3650	787102	703642	645966	610004	583541	561149	542828	526544
3700	809534	718745	657532	620391	592879	570182	551611	535104
3750	833676	733300	669171	630833	601557	579251	559734	543004
3800	860288	749397	680885	640625	610960	587652	567875	550923
3850	888024	764945	692673	651170	620400	596786	576035	558861
3900	919809	780642	705259	661770	629877	605233	584938	566817
3950	954315	797220	717205	671691	639391	614432	593143	574791
4000	990882	813965	729224	682393	648942	622925	601368	582784
4050	1039349	831630	742070	693150	658530	632189	609611	590796
4100	1090991	848718	755008	703963	668917	641490	618634	598826
4150	1142035	865972	768039	714832	678589	650828	626924	606874
4200	1193205	884174	781163	725756	689078	659423	635231	614941
4250	-	903350	794379	737525	698833	668826	643558	623027
4300	-	923529	807688	748570	708625	677467	652701	631131
4350	-	943930	821898	759670	718453	686935	661074	639254
4400	-	964553	835401	770825	729137	696440	669465	647395
4450	-	987052	848997	782863	739049	705155	677875	655555
4500	-	1008974	863521	794139	748998	714725	687139	663733
4550	-	1031137	877312	805470	758984	724331	695595	671929
4600	-	1055250	892049	817712	769008	733121	704069	680145
4650	-	1078776	907761	829163	779932	742792	713426	688378
4700	-	1104308	922730	840671	790039	752501	721947	696631
4750	-	1129254	937810	853116	801064	761364	730486	704901
4800	-	1156261	953893	865635	811254	771137	739935	713191
4850	-	1182681	969204	878229	822382	780948	748521	721498
4900	-	1210308	985537	890896	832656	790795	757125	730735
4950	-	1238250	1001999	902718	843885	800680	766667	739089
5000	-	1267435	1018591	915524	855170	810601	776246	747461
5050	-	1296016	1035312	928405	865573	820560	784924	755853
5100	-	1324911	1052163	941359	876960	830555	793621	764262
5150	-	1355077	1070100	955344	887446	840588	803292	772690
5200	-	1384612	1087219	967490	898935	850657	812035	781137
5250	-	1414461	1106418	980667	910480	860764	821771	789602
5300	-	1444625	1123816	994901	921096	870908	830561	798086
5350	-	1474110	1142336	1008235	933735	881088	840362	807582
5400	-	1503892	1161004	1021643	944444	890304	849197	816112
5450	-	1532958	1180833	1035126	956201	900549	859063	825672
5500	-	1562301	1200828	1049703	968014	910832	867945	834248
5550	-	1591923	1219959	1063343	979882	921151	877876	842843
5600	-	1621822	1239238	1078096	991806	931508	886804	851456
5650	-	1650950	1259715	1091893	1002737	941902	896799	860088
5700	-	1679280	1280358	1106822	1014763	952332	905774	868739
5750	-	1707850	1301168	1121844	1026844	962800	915834	877408
5800	-	1735584	1321068	1136958	1038981	974382	925932	887172
5850	-	1762454	1345459	1153251	1049002	981675	931722	892629
5900	-	1788433	1368978	1168560	1061232	991140	940762	901335
5950	-	1816806	1389387	1183961	1073517	1001728	949819	910059
6000	-	1845401	1411058	1199455	1084744	1013467	960009	918802
6050	-	1873096	1432896	1215041	1098254	1024138	969113	927564
6100	-	1900994	1456032	1230721	1110705	1034847	979368	936344
6150	-	1927954	1477071	1246492	1123213	1045592	989660	945142
6200	-	-	1499408	1262357	1135776	1056375	998838	955110

CROSBY H-SERIES

STYLE HCA-I STEAM CAPACITIES - SI (METRIC) UNITS

STEAM CAPACITY (kg/hr) - K - ORIFICE (1187.1 mm²)

Kilograms per hour at 3% overpressure

Set pressure, barg	Steam relieving temperature, T - (°C)								
	400	425	450	475	500	525	550	575	600
213.8	127870	118183	111644	106921	103046	99777	96992	94570	92269
215.0	128828	119086	112511	107640	103744	100456	97534	95099	92785
217.5	130812	120958	114060	109133	105068	101742	98786	96199	93982
220.0	132931	122840	115739	110506	106395	103031	100041	97549	95058
222.5	135065	124608	117300	112008	107850	104323	101299	98653	96259
225.0	137213	126511	118994	113516	109184	105617	102559	99884	97463
227.5	139375	128426	120697	115029	110650	107043	103823	101118	98541
230.0	141681	130482	122408	116548	112121	108344	105089	102354	99750
232.5	144005	132421	123997	118073	113466	109649	106358	103462	100961
235.0	146345	134504	125723	119604	114814	110956	107630	104703	102175
237.5	148836	136601	127459	121140	116299	112266	108905	105947	103258
240.0	151348	138577	129202	122681	117654	113579	110182	107193	104476
242.5	154016	140701	130955	124228	119149	115031	111462	108305	105697
245.0	156845	142839	132715	125781	120650	116351	112745	109556	106782
247.5	159560	145131	134484	127340	122016	117674	114031	110809	107868
250.0	162439	147299	136262	128904	123527	119141	115320	112066	109094
252.5	165629	149623	138191	130474	125043	120470	116612	113325	110324
255.0	169139	151821	139987	132194	126421	121803	117906	114443	111556
257.5	172685	154178	141791	133776	127801	123138	119203	115706	112646
260.0	176415	156699	143751	135364	129332	124476	120503	116972	113882
262.5	180482	159091	145574	136958	130868	125966	121806	118241	115122
265.0	184743	161650	147555	138707	132259	127311	123112	119513	116214
267.5	189204	164229	149396	140314	133805	128659	124421	120788	117458
270.0	194021	166828	151398	141926	135357	130162	125732	121913	118704
272.5	199203	169446	153257	143544	136760	131517	127046	123191	119799
275.0	204759	172240	155280	145322	138321	132875	128363	124473	121050
277.5	211010	175056	157315	146953	139888	134236	129683	125758	122304
280.0	218765	178053	159361	148747	141302	135599	131005	126887	123560
282.5	226465	180916	161418	150390	142879	137125	132331	128335	124659
285.0	233944	183963	163487	152200	144461	138657	133659	129628	125920
287.5	241519	186872	165729	154019	146050	140032	135153	130761	127183
290.0	249189	189968	167821	155682	147643	141409	136324	132059	128286
292.5	255136	193089	169925	157516	149243	142955	137661	133359	129553
295.0	-	196236	172207	159358	150848	144340	139167	134662	130824
297.5	-	199576	174334	161041	152290	145727	140511	135967	132097
300.0	-	202775	176643	162898	153905	147287	141857	137276	133203
302.5	-	206170	178795	164594	155526	148853	143207	138416	134481
305.0	-	209593	181130	166467	157324	150252	144559	139729	135761
307.5	-	213045	183479	168349	158784	151653	145914	141044	136870
310.0	-	216525	185843	170239	160421	153233	147272	142363	138155
312.5	-	220209	188221	172138	162064	154641	148809	143684	139442
315.0	-	223747	190612	174045	163713	156053	149996	145008	140732
317.5	-	227492	193198	175961	165367	157646	151362	146335	141846
320.0	-	231269	195619	177885	167027	159246	152912	147664	143140
322.5	-	235076	198237	179818	168693	160669	154286	148997	144438
325.0	-	239098	200688	181759	170364	162278	155662	150332	145738
327.5	-	243154	203338	183708	172226	163708	157041	151485	146855
330.0	-	247244	206005	185666	173724	165140	158423	153011	148160
332.5	-	251367	208689	187820	175412	166763	159995	154167	149467
335.0	-	255714	211390	189797	177295	168392	161384	155512	150777
337.5	-	259907	214108	191972	178996	169836	162776	156860	152089
340.0	-	264326	216843	193775	180703	171475	164170	158403	153405
342.5	-	268587	219595	195970	182415	172926	165567	159564	154530
345.0	-	273078	222559	197981	184132	174575	166968	160921	-
347.5	-	277605	225345	200198	186052	176033	168567	162477	-
350.0	-	281971	228149	202426	187783	177691	169974	-	-
352.5	-	286570	231169	204465	189519	179355	-	-	-
355.0	-	291206	234009	206714	191261	180825	-	-	-
357.5	-	295677	237067	208772	193210	-	-	-	-
360.0	-	300181	240144	210839	-	-	-	-	-
362.5	-	304924	243242	213119	-	-	-	-	-
365.0	-	309497	246153	-	-	-	-	-	-
367.5	-	313896	-	-	-	-	-	-	-

CROSBY H-SERIES

STYLE HCA-I STEAM CAPACITIES - SI (METRIC) UNITS

STEAM CAPACITY (kg/hr) - K2 - ORIFICE (1641.9 mm²)

Kilograms per hour at 3% overpressure

Set pressure, barg	Steam relieving temperature, T - (°C)								
	400	425	450	475	500	525	550	575	600
213.8	176863	163465	154421	147889	142529	138007	134155	130805	127623
215.0	178188	164715	155620	148883	143494	138946	134904	131536	128336
217.5	180932	167303	157762	150947	145325	140725	136636	133058	129992
220.0	183864	169907	160084	152847	147160	142508	138372	134926	131479
222.5	186816	172351	162244	154925	149174	144294	140112	136452	133141
225.0	189787	174984	164587	157010	151019	146085	141855	138155	134807
227.5	192777	177633	166943	159103	153046	148057	143603	139861	136298
230.0	195967	180477	169310	161204	155080	149857	145354	141572	137969
232.5	199181	183159	171506	163313	156941	151661	147109	143104	139645
235.0	202417	186040	173895	165430	158805	153469	148869	144820	141324
237.5	205863	188941	176295	167555	160860	155281	150632	146540	142821
240.0	209337	191673	178707	169687	162734	157097	152399	148265	144506
242.5	213028	194611	181130	171827	164802	159106	154170	149803	146195
245.0	216941	197568	183566	173975	166878	160931	155944	151533	147696
247.5	220696	200738	186012	176131	168768	162761	157723	153266	149197
250.0	224678	203737	188471	178294	170857	164790	159506	155004	150894
252.5	229090	206952	191139	180465	172954	166629	161292	156746	152595
255.0	233945	209991	193623	182844	174859	168472	163082	158292	154299
257.5	238850	213251	196119	185033	176769	170319	164877	160039	155806
260.0	244009	216738	198830	187229	178885	172170	166675	161791	157517
262.5	249634	220047	201351	189434	181010	174230	168477	163546	159231
265.0	255528	223587	204091	191853	182935	176090	170283	165305	160742
267.5	261698	227154	206637	194075	185073	177955	172093	167068	162462
270.0	268361	230748	209406	196305	187219	180034	173906	168624	164186
272.5	275529	234370	211978	198543	189159	181909	175724	170393	165701
275.0	283213	238234	214777	201003	191319	183787	177546	172166	167431
277.5	291858	242130	217591	203258	193486	185669	179371	173942	169165
280.0	302585	246275	220421	205740	195442	187555	181201	175504	170903
282.5	313236	250235	223266	208013	197623	189665	183034	177507	172423
285.0	323580	254449	226127	210517	199812	191784	184871	179296	174167
287.5	334057	258473	229228	213032	202009	193686	186937	180863	175914
290.0	344667	262755	232123	215332	204213	195591	188557	182657	177439
292.5	-	267072	235032	217868	206426	197729	190406	184456	179192
295.0	-	271424	238188	220417	208646	199644	192489	186258	180949
297.5	-	276044	241131	222744	210641	201563	194348	188064	182710
300.0	-	280468	244324	225313	212874	203721	196210	189873	184241
302.5	-	285165	247300	227658	215116	205886	198077	191451	186008
305.0	-	289900	250531	230249	217604	207821	199947	193266	187778
307.5	-	294674	253780	232852	219622	209759	201821	195086	189313
310.0	-	299487	257049	235467	221887	211944	203699	196909	191089
312.5	-	304583	260338	238093	224160	213893	205826	198737	192870
315.0	-	309476	263646	240731	226440	215845	207467	200568	194655
317.5	-	314657	267222	243381	228728	218049	209357	202403	196195
320.0	-	319880	270571	246042	231024	220262	211501	204242	197985
322.5	-	325146	274192	248715	233328	222229	213401	206085	199779
325.0	-	330709	277582	251400	235640	224455	215304	207932	201577
327.5	-	336319	281248	254096	238215	226433	217211	209527	203123
330.0	-	341976	284937	256805	240286	228414	219123	211638	204927
332.5	-	347680	288649	259784	242621	230659	221298	213236	206735
335.0	-	353692	292385	262518	245226	232913	223219	215097	208547
337.5	-	359491	296145	265527	247579	234910	225144	216961	210363
340.0	-	365603	299927	268020	249939	237176	227072	219096	212182
342.5	-	371498	303733	271056	252307	239183	229005	220702	213738
345.0	-	377709	307833	273839	254683	241464	230942	222578	215564
347.5	-	383971	311687	276904	257339	243480	233154	224730	217393
350.0	-	390009	315565	279986	259732	245774	235100	226342	218952
352.5	-	396371	319743	282807	262134	248076	237050	228230	220788
355.0	-	402783	323670	285917	264543	250108	239282	230122	222627
357.5	-	408966	327899	288764	267239	252424	241242	232017	-
360.0	-	415196	332157	291622	269666	254747	243206	233917	-
362.5	-	421756	336441	294776	272100	257078	245457	-	-
365.0	-	428081	340467	297945	274828	259132	247431	-	-
367.5	-	434166	344804	301129	277280	261477	-	-	-
370.0	-	440294	348879	304329	280029	-	-	-	-
372.5	-	446756	353269	307545	282499	-	-	-	-
375.0	-	446756	353269	307545	-	-	-	-	-
377.5	-	459230	362426	-	-	-	-	-	-
380.0	-	465531	-	-	-	-	-	-	-
382.5	-	471875	-	-	-	-	-	-	-

CROSBY H-SERIES

SIZING

SIZING ASME SECTION I SAFETY VALVES

ASME Section I safety valves are devices designed to protect power boilers during an overpressure event. The proper sizing, selection, manufacturing, assembly, testing and maintenance are all critical to obtain optimum protection.

ASME code Section I

1 Boilers-safety valve requirements (PG-67)

- a. Boilers having more than 500 sq. ft. of bare tube and boilers having combined bare tube and extended water heating surfaces exceeding 500 sq. ft. as well as a design steam generating capacity exceeding 4000 lb/hr (1814 kg/hr) must have two or more safety valves. If only two safety valves are used, the relieving capacity of the smaller must not be less than 50% of that of the larger, so if only two valves are used, select valves so that each will relieve approximately half of the total boiler capacity.

2 Superheater safety valve requirements (PG-68)

- a. Boilers having attached superheaters must have at least one valve on the superheater. The valves on the drum must be large enough to relieve at least 75% of the total boiler capacity. It is good practice to size the superheater valve to relieve approximately 20% of the total boiler capacity to protect the tubes against overheating.

3 Reheater safety valve requirements (PG-68)

- a. Boilers having reheaters must have at least one safety valve on the reheater outlet capable of relieving a minimum of 15% of the flow through the reheater. The remainder of the flow through the reheater may be discharged by safety valves on the reheater inlet.

4 Economizer safety relief valves requirements (PG-67) (closed bonnet type valve)

- a. Any economizer which may be shut off from the boiler, thereby permitting the economizer to become a fired pressure vessel, shall have one or more safety relief valves with a total discharge capacity, in lbs/hr, calculated from the maximum expected heat absorption in BTU/hr, as determined by the manufacturer, divided by 1000.

Safety relief valves in hot water service are more susceptible to damage and subsequent leakage than safety valves relieving steam. It is recommended that the maximum allowable working pressure of the boiler and the safety relief valve setting be selected substantially higher than the desired operating pressure so as to minimize the times the safety valve must lift.

5 Organic fluid vaporizer safety valve requirements (Dowtherm service, PVG-12)

- a. Safety valves shall be totally enclosed and shall not discharge to atmosphere, except through an escape pipe that will carry such vapors to a safe point of discharge outside of the building.
The safety valve shall not have a lifting lever and valve body drains are not mandatory. A rupture disc may be installed between the safety valve and the vaporizer.

The required minimum safety valve relieving capacity shall be determined from the formula:

$$W = \frac{C \times H \times 0.75}{h}$$

where:

h = Latent heat of heat transfer fluid at relieving pressure, Btu/lb

W = Weight of organic fluid vapor generated per hour, lb

C = Maximum total weight or volume of fuel burned per hour, lb or cu ft

H = Heat of combustion of fuel, Btu/lb or Btu/cu ft

The sum of the safety valve capacities marked on the valves shall be equal to or greater than W.

CROSBY H-SERIES

SIZING

6 Sample calculations - boiler set sizing

Boiler Specifications:

- Total steam generation: 1450000 lbs/hr
- Design pressure (MAWP): 3000 psig
- Drum operating pressure: 2835 psig
- S.H. outlet temperature: 1000°F
- S.H. outlet operating pressure: 2680 psig

The superheater valve should relieve between 15% and 20% of the total generation capacity, or 217500 lbs/hr to 290000 lbs/hr

The superheater safety valve should be set to operate before the low set drum valve.

To determine superheater safety valve set pressure:

$2835 \text{ psig (drum operating pressure)} - 2680 \text{ psig (superheater outlet operating pressure)} = 155 \text{ psi (SH pressure drop)}$.

$3000 \text{ psig (design pressure)} - 155 \text{ psi} - 20 \text{ psig* (SH pressure drop)} = 2825 \text{ psig (set pressure)**}$.

* The 20 psig subtracted from the superheater pressure drop is done to ensure that the superheater safety valve opens before the low set drum safety valve.

** Can round set pressure up or down for even number.

The superheat correction factor K_{sh} is found on pages 62-63. First convert set pressure gauge to flowing pressure absolute by:
 $2825 \text{ psig} \times 1.03 + 14.7 = 2924.45 \text{ psia}$.
At 2924.45 psia and 1000F the $K_{sh} = 0.711$

To relieve 217,500 lbs/hr superheated steam, the superheater valve must relieve $217500/0.711 = 305907 \text{ lb/hr}$ saturated steam. From capacity table, page 52, a K2 orifice valve set at 2825 psig will relieve 381228 lbs/hr saturated steam or $381228 \times 0.711 = 271053 \text{ lbs/hr}$ superheated steam.

A 2½ x K2 x 6 HCI-98W with welded inlet is required.

The balance of steam to be relieved by drum valves:

$1450000 - 271053 = 1178947 \text{ lbs/hr}$ (drum valves must relieve a minimum of 75% total boiler cap).

Low set drum valve must = 3000 psig (MAWP-PG-67.3)

High set drum valve = $1.03 \times 3000 = 3090 \text{ psig (PG-67.2)}$

The average set pressure for drum valve = 3045 psig.

From capacity table, page 52, at 3045 psig; two M orifice valves will discharge $604733 \times 2 + 1209466 \text{ lbs/hr}$. Selection should be based on price comparison and also on using as many valves as practical of the same size. In this case, two M orifice valves should be used. Actual valve capacities from capacity Table, page 50:

1st drum valve, 3 x M x 6 HE-96W
3000 psig - 590497 lbs/hr

2nd drum valve, 3 x M x 6 HE-96W
3090 psig - 619478 lbs/hr

Total capacity drum valves:
1209975 lbs/hr (83.4%)

Capacity of superheater valve:
271053 lbs/hr (18.7%)

Total safety valve capacity:
1481028 (102%)

Rechecking, the drum valves relieve 83.4% of total boiler capacity (complying with ASME code requirement that drum valves relieve at least 75% of boiler capacity). Superheater valve relieves 18.7% of total boiler capacity - within the desirable range of 15% to 20% of total boiler capacity.

CROSBY H-SERIES

PRESSURE / TEMPERATURE LIMITS

Pressure/temperature limits - Standard class valves (reference ASME/ANSI B16.34)

PRESSURE/TEMPERATURE LIMITS - BODY MATERIAL: SA 216 GR. WCB

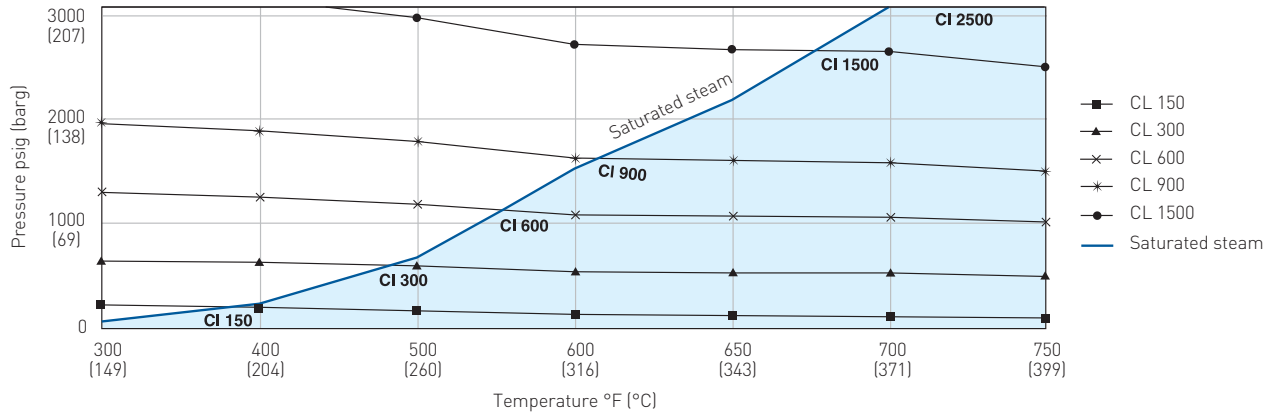

PRESSURE/TEMPERATURE LIMITS - BODY MATERIAL: SA 216 GR. WCC

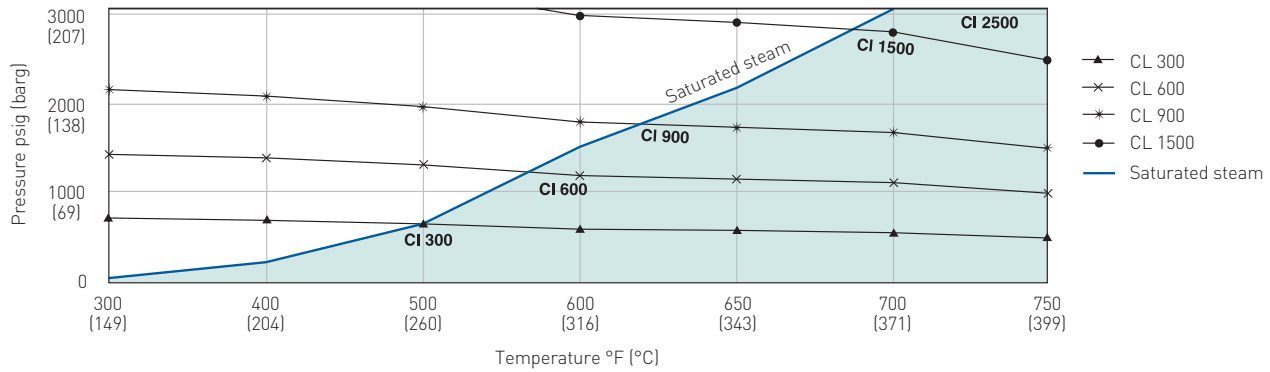

PRESSURE/TEMPERATURE LIMITS - BODY MATERIAL: SA 217 GR. WC6

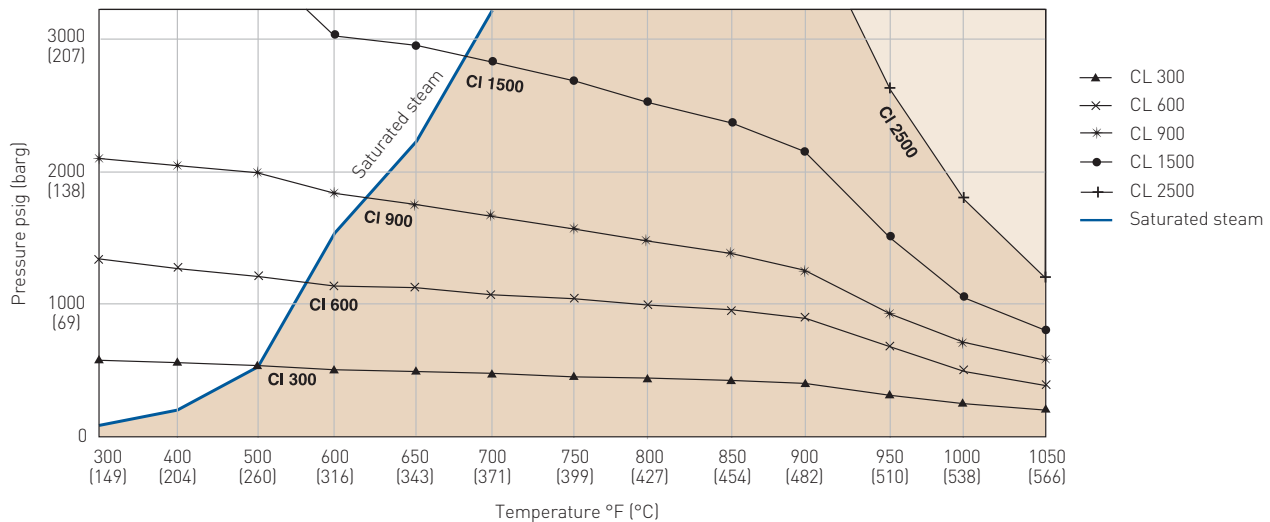

CROSBY H-SERIES

PRESSURE / TEMPERATURE LIMITS

Pressure/temperature limits - Standard class valves (reference ASME/ANSI B16.34)

PRESSURE/TEMPERATURE LIMITS - BODY MATERIAL: SA 217 GR. WC9

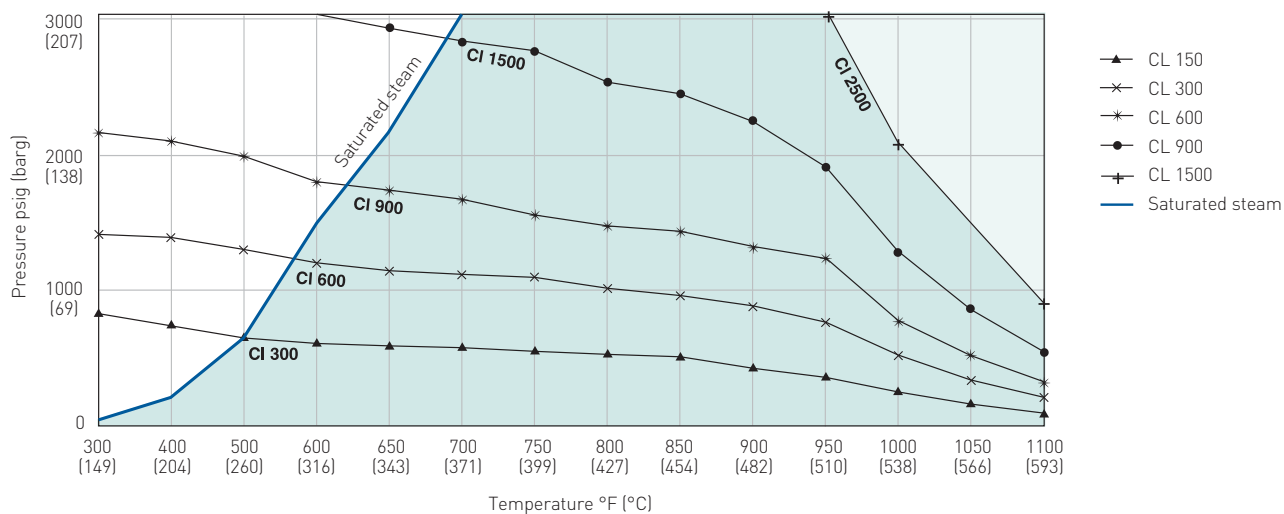

PRESSURE/TEMPERATURE LIMITS - BODY MATERIAL: SA 217 GR. C12A

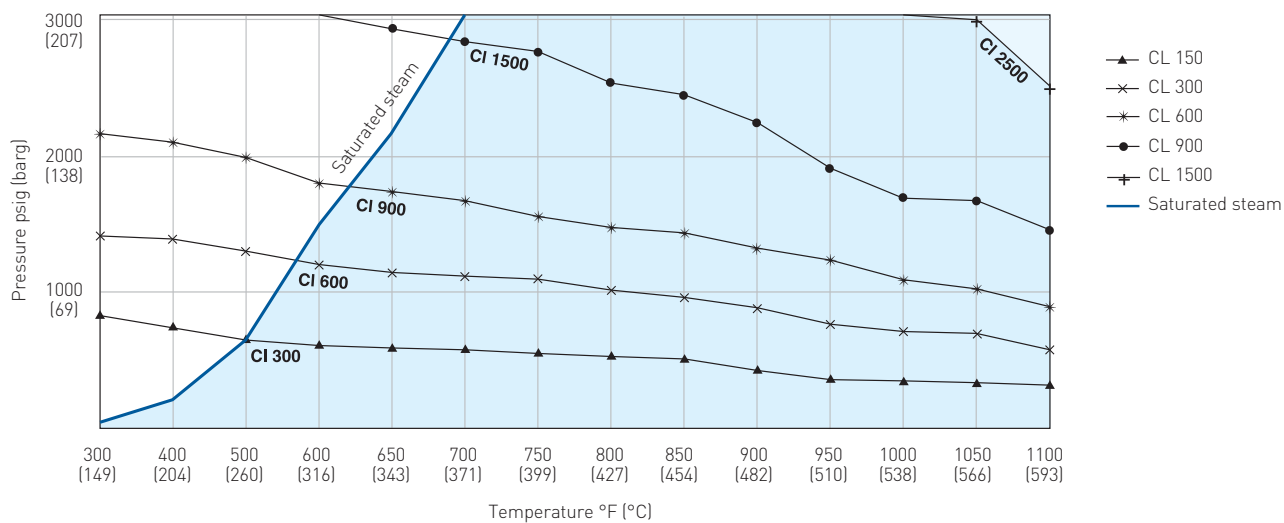

CROSBY H-SERIES
 PRESSURE / TEMPERATURE LIMITS

Pressure/temperature limits - Standard class valves - reference ASME/ANSI B16.34

PRESSURE/TEMPERATURE LIMITS FOR STYLE HSJ-()6 VALVES

Body material: SA 216 Gr. WCB													
Temperature		Working pressure by classes psig (barg)											
°F	[°C]	ANSI Standard class											
		150		300		600		900		1500		2500	
300	[149]	230	[15.9]	655	[45.2]	1315	[90.7]	1970	[135.8]	3280	[226.2]	5470	[377.2]
400	[204]	200	[13.8]	635	[43.8]	1270	[87.6]	1900	[131.0]	3170	[218.6]	5280	[364.1]
500	[260]	170	[11.7]	600	[41.4]	1200	[82.7]	1795	[123.8]	2995	[206.5]	4990	[344.1]
600	[316]	140	[9.7]	550	[37.9]	1095	[75.5]	1640	[113.1]	2735	[188.6]	4560	[314.4]
650	[343]	125	[8.6]	535	[36.9]	1075	[74.1]	1610	[111.0]	2685	[185.1]	4475	[308.6]
700	[371]	110	[7.6]	535	[36.9]	1065	[73.4]	1600	[110.3]	2665	[183.8]	4440	[306.1]
750	[399]	95	[6.6]	505	[34.8]	1010	[69.6]	1510	[104.1]	2520	[173.8]	4200	[289.6]

PRESSURE/TEMPERATURE LIMITS FOR STYLE HCI-()6 VALVES

Body material: SA 216 Gr. WCC											
Temperature		Working pressure by classes psig (barg)									
°F	[°C]	ANSI Standard class									
		300		600		900		1500		2500	
300	[149]	730	[50.3]	1455	[100.3]	2185	[150.7]	3640	[251.0]	6070	[418.5]
400	[204]	705	[48.6]	1410	[97.2]	2115	[145.8]	3530	[243.4]	5880	[405.4]
500	[260]	665	[45.9]	1330	[91.7]	1995	[137.6]	3325	[229.3]	5540	[382.0]
600	[316]	605	[41.7]	1210	[83.4]	1815	[125.1]	3025	[208.6]	5040	[347.5]
650	[343]	590	[40.7]	1175	[81.0]	1765	[121.7]	2940	[202.7]	4905	[338.2]
700	[371]	570	[39.3]	1135	[78.3]	1705	[117.6]	2840	[195.8]	4730	[326.1]
750	[399]	505	[34.8]	1010	[69.6]	1510	[104.1]	2520	[173.8]	4200	[289.6]

PRESSURE/TEMPERATURE LIMITS FOR STYLE HSJ-()7 AND HCI-()8 VALVES

Body material: SA 216 Gr. WC6											
Temperature		Working pressure by classes psig (barg)									
°F	[°C]	ANSI Standard class									
		300		600		900		1500		2500	
300	[149]	720	[49.6]	1445	[99.6]	2165	[149.3]	3610	[248.9]	6015	[414.7]
400	[204]	695	[47.9]	1385	[95.5]	2080	[143.4]	3465	[238.9]	5775	[398.2]
500	[260]	665	[45.9]	1330	[91.7]	1995	[137.6]	3325	[229.3]	5540	[382.0]
600	[316]	605	[41.7]	1210	[83.4]	1815	[125.1]	3025	[208.6]	5040	[347.5]
650	[343]	590	[40.7]	1175	[81.0]	1765	[121.7]	2940	[202.7]	4905	[338.2]
700	[371]	570	[39.3]	1135	[78.3]	1705	[117.6]	2840	[195.8]	4730	[326.1]
750	[399]	530	[36.5]	1065	[73.4]	1595	[110.0]	2660	[183.4]	4430	[305.4]
800	[427]	510	[35.2]	1015	[70.0]	1525	[105.1]	2540	[175.1]	4230	[291.7]
850	[454]	485	[33.4]	975	[67.2]	1460	[100.7]	2435	[167.9]	4060	[279.9]
900	[482]	450	[31.0]	900	[62.1]	1350	[93.1]	2245	[154.8]	3745	[258.2]
950	[510]	320	[22.1]	640	[44.1]	955	[65.8]	1595	[110.0]	2655	[183.1]
1000	[538]	215	[14.8]	430	[29.6]	650	[44.8]	1080	[74.5]	1800	[124.1]
1050	[566]	145	[10.0]	290	[20.0]	430	[29.6]	720	[49.6]	1200	[82.7]

CROSBY H-SERIES

PRESSURE / TEMPERATURE LIMITS

Pressure/temperature limits - Standard class valves - reference ASME/ANSI B16.34

PRESSURE/TEMPERATURE LIMITS FOR STYLES HCI-()9 VALVES

Body material: SA 217 Gr. WC9					
Working pressure by classes psig (barg) per ASME/ANSI B16.34					
Temperature °F (°C)	Inlet flange: ANSI Standard class				
	CL 300	CL 600	CL 900	CL 1500	CL 2500
300 (149)	730 (50.3)	1455 (100.3)	2185 (150.7)	3640 (251.0)	6070 (418.5)
400 (204)	705 (48.6)	1410 (97.2)	2115 (145.8)	3530 (243.4)	5880 (405.4)
500 (260)	665 (45.9)	1330 (91.7)	1995 (137.6)	3325 (229.3)	5540 (382.0)
600 (316)	605 (41.7)	1210 (83.4)	1815 (125.1)	3025 (208.6)	5040 (347.5)
650 (343)	590 (40.7)	1175 (81.0)	1765 (121.7)	2940 (202.7)	4905 (338.2)
700 (371)	570 (39.3)	1135 (78.3)	1705 (117.6)	2840 (195.8)	4730 (326.1)
750 (399)	530 (36.5)	1065 (73.4)	1595 (110.0)	2660 (183.4)	4430 (305.4)
800 (427)	510 (35.2)	1015 (70.0)	1525 (105.1)	2540 (175.1)	4230 (291.6)
850 (454)	485 (33.4)	975 (67.2)	1460 (100.7)	2435 (167.9)	4060 (279.9)
900 (482)	450 (31.0)	900 (62.1)	1350 (93.1)	2245 (154.8)	3745 (258.2)
950 (510)	375 (25.9)	755 (52.1)	1130 (77.9)	1885 (130.0)	3145 (216.8)
1000 (538)	260 (17.9)	520 (35.9)	780 (53.8)	1305 (90.0)	2170 (149.6)
1050 (566)	175 (12.1)	350 (24.1)	525 (36.2)	875 (60.3)	1455 (100.3)
1100 (593)	110 (7.6)	220 (15.2)	330 (22.8)	550 (37.9)	915 (63.1)

Body material: SA 217 Gr. C12A					
Working pressure by classes psig (barg) per ASME/ANSI B16.34					
Temperature °F (°C)	Inlet flange: ANSI Standard class				
	CL 300	CL 600	CL 900	CL 1500	CL 2500
300 (149)	730 (50.3)	1455 (100.3)	2185 (150.7)	3640 (251.0)	6070 (418.5)
400 (204)	705 (48.6)	1410 (97.2)	2115 (145.8)	3530 (243.4)	5880 (405.4)
500 (260)	665 (45.9)	1330 (91.7)	1995 (137.6)	3325 (229.3)	5540 (382.0)
600 (316)	605 (41.7)	1210 (83.4)	1815 (125.1)	3025 (208.6)	5040 (347.5)
650 (343)	590 (40.7)	1175 (81.0)	1765 (121.7)	2940 (202.7)	4905 (338.2)
700 (371)	570 (39.3)	1135 (78.3)	1705 (117.6)	2840 (195.8)	4730 (326.1)
750 (399)	530 (36.5)	1065 (73.4)	1595 (110.0)	2660 (183.4)	4430 (305.4)
800 (427)	510 (35.2)	1015 (70.0)	1525 (105.1)	2540 (175.1)	4230 (291.6)
850 (454)	485 (33.4)	975 (67.2)	1460 (100.7)	2435 (167.9)	4060 (279.9)
900 (482)	450 (31.0)	900 (62.1)	1350 (93.1)	2245 (154.8)	3745 (258.2)
950 (510)	385 (26.5)	775 (53.4)	1160 (80.0)	1930 (133.1)	3220 (222.0)
1000 (538)	365 (25.2)	725 (50.0)	1090 (75.2)	1820 (125.5)	3030 (208.9)
1050 (566)	360 (24.8)	720 (49.6)	1080 (74.5)	1800 (124.1)	3000 (206.8)
1100 (593)	300 (20.7)	605 (41.7)	905 (62.4)	1510 (104.1)	2515 (173.4)

Body Material : SA217-WC9 Nozzle Material: SB564 N06625										
Valve Size Inlet x Orifice X Outlet	Orifice Area Sq. In. (Sq. mm.)	Inlet Type	Maximum Set pressure psig (barg)							Standard Flanged Outlet Class
			Temperature							
			750°F (399°C)	800°F (426°C)	850°F (454°C)	900°F (482°C)	950°F (510°C)	1000°F (538°C)	1050°F (566°C)	
2.5 K 6	1.840 (1186)	*	4200 (290)	5350 (368)	5300 (365)	5250 (362)	5200 (358)	5150 (355)	5050 (348)	6 CL. 300
2.5 K2 6	2.545 (1642)	*	4200 (290)	5550 (382)	5500 (379)	5450 (375)	5400 (372)	5350 (368)	5250 (362)	6 CL. 300
3 M 8	3.600 (2323)	*	4200 (290)	6150 (424)	6200 (427)	6200 (427)	6200 (427)	6200 (427)	5300 (365)	8 CL. 300
3 M2 8	3.976 (2565)	*	4200 (290)	6150 (424)	6200 (427)	6200 (427)	6200 (427)	5840 (403)	3800 (262)	8 CL. 300

* Butt Weld

Body Material : SA217-C12A Nozzle Material: SB564 N06625											
Valve Size Inlet x Orifice X Outlet	Orifice Area Sq. In. (Sq. mm.)	Inlet Type	Maximum Set pressure psig (barg)							Standard Flanged Outlet Class	
			Temperature								
			750°F (399°C)	800°F (426°C)	850°F (454°C)	900°F (482°C)	950°F (510°C)	1000°F (538°C)	1050°F (566°C)		1100°F (566°C)
2.5 K 6	1.840 (1186)	*	4200 (290)	5350 (368)	5300 (365)	5250 (362)	5200 (358)	5150 (355)	5050 (348)	5000 (344)	6 CL. 300
2.5 K2 6	2.545 (1642)	*	4200 (290)	5550 (382)	5500 (379)	5450 (375)	5400 (372)	5350 (368)	5250 (362)	5150 (355)	6 CL. 300
3 M 8	3.600 (2323)	*	4200 (290)	6150 (424)	6200 (427)	6200 (427)	6200 (427)	6200 (427)	6200 (427)	6200 (427)	8 CL. 300
3 M2 8	3.976 (2565)	*	4200 (290)	6150 (424)	6200 (427)	6200 (427)	6200 (427)	6200 (427)	6200 (427)	6200 (427)	8 CL. 300

* Butt Weld

CROSBY H-SERIES

OUTLET REACTION FORCES

OUTLET REACTION FORCES STYLES HE, HCI, HSJ

Total resultant force at outlet elbow*

The figure (right) shows a safety valve open and discharging at full capacity, with a 90° outlet elbow. The horizontal reaction force (F_h) is balanced by the force of discharging steam acting on the 90° elbow.

The vertical force (F_v) at the 90° elbow is unbalanced and exerts a bending moment on the valve. The vertical force (F_v) is the resultant of the reaction due to velocity and the static pressure of the steam acting on the area of the elbow when the valve is open and discharging.

The basic equation for this is:

$$F_v = \frac{WV + (AP_e)}{g_c}$$

where:

- F_v = Vertical force
- W = Flow in lbs/sec
- V = Velocity, ft/sec
- A = Area of outlet, sq. in.
- P_e = Static pressure in outlet elbow, psig
- g_c = Gravitational constant

* Determination of outlet reaction forces is the responsibility of the designer of the vessel and/or piping.

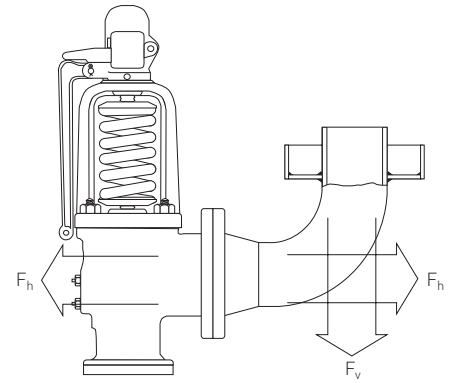

TOTAL OUTLET REACTION FORCE - lbs (STYLES HE, HCI, HSJ)

Flowing press. ⁽¹⁾ (psia)	Orifice designation												
	F	F	G	G	H	H2	H2	J	J	J2	J2	K	K
	Outlet diameter												
	2"	2.5"	2.5"	3"	3"	3"	4"	3"	4"	4"	6"	4"	6"
Total outlet reaction force - lbs [Styles HE, HCI, HSJ]													
100	20.5	20.5	33.6	33.6	52.5	-	-	86.2	86.2	-	-	123.1	-
200	41.7	41.7	68.3	68.3	106.6	-	-	205.6	175.0	-	-	257.4	-
300	65.2	62.9	110.3	103.1	180.8	256.6	203.8	363.2	282.4	334.2	293.4	482.6	-
400	102.6	84.1	171.6	139.8	276.5	377.8	297.0	520.2	439.4	508.7	392.0	706.9	-
500	139.8	113.8	232.5	200.8	371.6	498.2	417.4	-	595.4	682.1	490.0	929.8	-
600	176.6	150.7	292.9	261.2	465.8	617.5	536.7	-	750.1	853.8	622.9	1150.7	-
700	213.1	187.1	352.6	320.9	559.1	735.6	654.8	-	903.0	1023.8	792.9	1369.2	-
800	249.1	223.1	411.7	379.9	651.2	852.2	771.4	-	1054.2	1191.7	960.8	1585.1	-
900	284.6	258.7	469.9	438.1	742.0	967.2	886.4	-	1203.2	1357.3	1126.4	1798.0	-
1000	319.6	293.6	527.2	495.4	831.5	1080.5	999.7	-	1350.0	1520.4	1289.5	2007.7	-
1100	349.6	323.6	576.3	544.6	908.2	1177.6	1096.8	-	1475.9	1660.2	1429.3	2187.5	-
1200	383.0	357.0	631.0	599.2	993.4	1285.6	1204.7	-	1615.7	1815.6	1584.7	2387.3	-
1300	-	389.6	684.4	652.7	1076.9	1391.2	1310.4	-	1752.7	1967.8	1736.8	-	-
1400	-	421.5	736.7	705.0	1158.4	1494.5	1413.7	-	1886.5	2116.5	1885.5	-	-
1500	-	450.3	783.9	752.2	1232.1	1587.8	1507.0	-	2007.4	2250.7	2019.8	-	-
1600	-	483.4	838.1	806.4	1316.7	1694.9	1614.1	-	2146.2	2404.9	2174.0	-	-
1700	-	516.1	891.6	859.9	1400.2	1800.6	1719.8	-	2283.1	2557.1	2326.2	-	-
1800	-	548.3	944.4	912.6	1482.5	-	1824.1	-	-	-	2476.3	-	-
1900	-	579.9	996.2	964.4	1563.4	-	1926.5	-	-	-	2623.7	-	-
2000	-	610.9	1047.0	1015.3	1642.7	-	2026.9	-	-	-	2768.3	-	-
2100	-	641.2	1096.6	1064.8	1720.1	-	2124.9	-	-	-	2909.4	-	3859.7
2200	-	670.6	1144.8	1113.0	1795.3	-	2220.1	-	-	-	3046.4	-	4035.9
2300	-	698.9	1191.3	1159.5	1867.8	-	2312.0	-	-	-	3178.7	-	4206.0
2400	-	726.1	1235.7	1204.0	1937.2	-	2399.8	-	-	-	3305.1	-	4368.6
2500	-	751.5	1277.4	1245.7	2002.3	-	2482.2	-	-	-	3423.8	-	4521.1
2600	-	774.9	1315.7	1284.0	2062.1	-	2557.9	-	-	-	3532.8	-	4661.3
2700	-	795.4	1349.3	1317.6	2114.5	-	2624.3	-	-	-	3628.4	-	4784.2
2800	-	811.7	-	-	-	-	2677.1	-	-	-	3704.3	-	4881.9
2900	-	-	-	-	-	-	2708.6	-	-	-	3749.8	-	4940.3
3000	-	-	-	-	-	-	2702.1	-	-	-	3740.3	-	4928.2
3100	-	-	-	-	-	-	2611.5	-	-	-	3609.9	-	4760.4
3200	-	-	-	-	-	-	1914.8	-	-	-	2607.0	-	3470.9

NOTE

1. Flowing pressure is the valve set pressure plus the overpressure plus the atmospheric pressure (14.7 psia).

CROSBY H-SERIES
OUTLET REACTION FORCES

OUTLET REACTION FORCES STYLES HE, HCI, HSJ

TOTAL OUTLET REACTION FORCE - lbs (STYLES HE, HCI, HSJ) (continued)

Flowing press. ^[1] (psia)	Orifice designation														
	K2	L	L	L2	M	M2	N	P	P2	P2	Q	Q2	R	R	RR
	Outlet diameter														
	6"	4"	6"	6"	6"	6"	6"	6"	6"	8"	8"	8"	8"	10"	10"
Total outlet reaction force - lbs (Styles HE, HCI, HSJ)															
100	-	190.8	190.8	-	240.8	-	290.4	426.8	-	-	738.8	-	-	-	-
200	-	500.9	387.6	-	489.0	-	627.5	1117.5	-	-	1915.3	-	-	-	-
300	521.7	849.9	619.0	796.0	889.9	1026.3	1158.6	1898.1	2148.3	-	3266.6	3703.6	5063.5	4647.9	5841.0
400	817.6	1197.8	966.9	1203.4	1328.9	1511.1	1688.0	2676.0	3010.4	-	4613.4	5197.3	7014.5	6598.9	8193.2
500	1125.9	1543.4	1312.5	1608.1	1764.9	1992.7	2213.8	3448.8	3866.8	-	5951.2	6681.1	8952.6	8536.9	10529.7
600	1431.4	1885.9	1655.0	2009.2	2197.1	2470.0	2734.9	4214.8	4715.5	-	7277.2	8151.7	10873.4	10457.7	12845.5
700	1733.7	2224.8	1993.8	2406.0	2624.7	2942.3	3250.5	4972.5	5555.3	-	8589.1	9606.7	12773.8	12358.1	15136.7
800	2032.3	-	2328.6	2798.0	3047.1	3408.8	3759.9	5721.1	6384.8	-	-	11044.1	14651.1	14235.5	17400.0
900	2326.8	-	2658.7	3184.6	3463.7	3868.9	4262.2	6459.4	7202.9	-	-	12461.6	16502.6	16086.9	19632.2
1000	2616.9	-	2983.9	3565.4	3874.0	4322.0	4756.9	7186.5	8008.7	-	-	13857.6	18326.0	17910.4	21830.6
1100	2865.6	-	-	3891.8	-	4710.5	-	-	8699.5	-	-	15054.7	-	19473.8	23715.5
1200	3141.9	-	-	4254.6	-	5142.3	-	-	9467.2	-	-	16384.9	-	21211.2	25810.2
1300	3412.5	-	-	4609.8	-	5565.0	-	-	10218.9	-	-	17687.3	-	22912.4	27861.1
1400	3677.0	-	-	4957.0	-	5978.1	-	-	10953.6	-	-	18960.2	-	24574.9	29865.5
1500	3915.8	-	-	5270.5	-	6351.2	-	-	11617.0	11293.7	-	20109.7	-	26076.2	31675.6
1600	4190.0	-	-	5630.5	-	6779.7	-	-	12378.9	12055.6	-	21429.8	-	27800.5	33754.4
1700	4460.7	-	-	5985.9	-	7202.6	-	-	13130.8	12807.5	-	22732.6	-	29502.1	35805.9
1800	4727.6	-	-	6336.3	-	7619.5	-	-	-	13549.0	-	-	-	-	-
1900	4989.8	-	-	6680.5	-	8029.2	-	-	-	14277.4	-	-	-	-	-
2000	5247.0	-	-	7018.1	-	8430.9	-	-	-	14991.8	-	-	-	-	-
2100	5497.9	-	-	7347.4	7949.2	8822.9	-	-	-	15688.8	-	-	-	-	-
2200	5741.6	-	-	7667.4	8294.0	9203.6	-	-	-	16365.8	-	-	-	-	-
2300	5976.8	-	-	7976.1	8626.7	9571.1	-	-	-	17019.2	-	-	-	-	-
2400	6201.7	-	-	8271.4	8944.8	9922.5	-	-	-	17644.0	-	-	-	-	-
2500	6412.7	-	-	8548.3	9243.2	10252.1	-	-	-	18230.0	-	-	-	-	-
2600	6606.6	-	-	8802.9	9517.6	10555.1	-	-	-	18768.8	-	-	-	-	-
2700	6776.5	-	-	9026.0	9757.9	10820.5	-	-	-	19240.9	-	-	-	-	-
2800	6911.6	-	-	9203.3	9949.0	11031.5	-	-	-	19616.1	-	-	-	-	-
2900	6992.4	-	-	9309.4	10063.3	11157.8	-	-	-	19840.6	-	-	-	-	-
3000	6975.7	-	-	9287.4	10039.6	11131.6	-	-	-	19794.1	-	-	-	-	-
3100	6743.7	-	-	8982.9	9711.5	10769.2	-	-	-	19149.6	-	-	-	-	-
3200	4960.0	-	-	6641.3	7188.4	7982.6	-	-	-	14194.6	-	-	-	-	-

NOTE

1. Flowing pressure is the valve set pressure plus the overpressure plus the atmospheric pressure (14.7 psia).

CROSBY H-SERIES

OUTLET REACTION FORCES

OUTLET REACTION FORCES* STYLES HE, HCI, HSJ

Total resultant force at outlet elbow

The figure (right) shows a safety valve open and discharging at full capacity, with a 90° outlet elbow. The horizontal reaction force (F_h) is balanced by the force of discharging steam acting on the 90° elbow.

The vertical force (F_v) at the 90° elbow is unbalanced and exerts a bending moment on the valve. The vertical force (F_v) is the resultant of the reaction due to velocity and the static pressure of the steam acting on the area of the elbow when the valve is open and discharging.

The basic equation for this is:

$$F_v = \frac{WV + (AP_e)}{g_c}$$

where:

- F_v = Vertical force - (kN)
- W = Flow in
- V = Velocity
- A = Area of outlet, sq. mm
- P_e = Static pressure in outlet elbow, barg
- g_c = Gravitational constant

* Determination of outlet reaction forces is the responsibility of the designer of the vessel and/or piping.

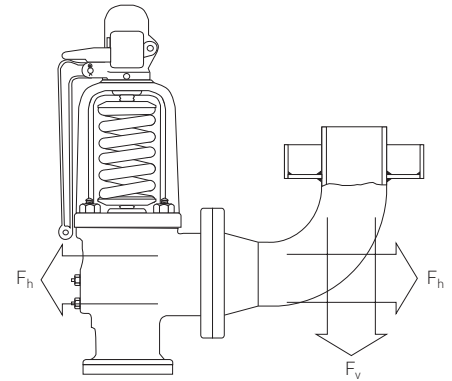

TOTAL OUTLET REACTION FORCE - kN (STYLES HE, HCI, HSJ)

Flowing press. ⁽¹⁾ [bar a]	Orifice designation												
	F	F	G	G	H	H2	H2	J	J	J2	J2	K	K
	Outlet diameter												
	2"	2.5"	2.5"	3"	3"	3"	4"	3"	4"	4"	6"	4"	6"
	Total outlet reaction force - kN [Styles HE, HCI, HSJ]												
6.9	91.4	91.4	149.7	149.7	233.7	-	-	383.4	383.4	-	-	547.7	-
13.8	185.6	185.6	304.1	304.1	474.5	-	-	915.0	778.6	-	-	1145.6	-
20.7	289.9	280.1	490.6	458.9	804.4	1141.7	906.8	1616.2	1256.5	1487.3	1305.4	2147.4	-
27.6	456.5	374.2	763.6	622.3	1230.4	1681.1	1321.5	2315.1	1955.4	2263.8	1744.3	3145.8	-
34.5	622.0	506.4	1034.7	893.4	1653.5	2216.9	1857.2	-	2649.7	3035.1	2180.4	4137.6	-
41.4	786.0	670.4	1303.4	1162.1	2072.9	2747.9	2388.3	-	3337.8	3799.6	2772.1	5120.6	-
48.3	948.3	832.7	1569.3	1428.0	2487.8	3273.3	2913.6	-	4018.5	4556.0	3528.4	6093.1	-
55.2	1108.6	993.0	1831.9	1690.6	2897.7	3792.3	3432.6	-	4691.1	5303.1	4275.6	7053.8	-
62.1	1266.6	1151.0	2090.9	1949.6	3301.9	4304.1	3944.5	-	5354.3	6040.0	5012.5	8001.3	-
69.0	1422.3	1306.7	2346.0	2204.7	3700.0	4808.2	4448.6	-	6007.5	6765.7	5738.2	8934.4	-
75.9	1555.8	1440.2	2564.7	2423.5	4041.4	5240.4	4880.8	-	6567.6	7388.0	6360.5	9734.5	-
82.8	1704.2	1588.6	2807.8	2666.5	4420.7	5720.8	5361.1	-	7189.9	8079.5	7051.9	10623.7	-
89.7	-	1733.8	3045.8	2904.5	4792.1	6191.1	5831.4	-	7799.3	8756.5	7729.0	-	-
96.6	-	1875.8	3278.4	3137.1	5155.1	6650.7	6291.0	-	8394.9	9418.2	8390.7	-	-
103.4	-	2004.0	3488.4	3347.1	5482.9	7065.7	6706.1	-	8932.7	10015.7	8988.2	-	-
110.3	-	2151.2	3729.6	3588.3	5859.3	7542.4	7182.8	-	9550.4	10702.0	9674.5	-	-
117.2	-	2296.5	3967.7	3826.4	6230.8	8012.8	7653.2	-	10160.0	11379.2	10351.7	-	-
124.1	-	2439.8	4202.4	4061.1	6597.2	-	8117.1	-	-	-	11019.5	-	-
131.0	-	2580.5	4433.0	4291.7	6957.1	-	8572.8	-	-	-	11675.6	-	-
137.9	-	2718.6	4659.2	4517.9	7310.0	-	9019.8	-	-	-	12319.1	-	-
144.8	-	2853.2	4879.9	4738.6	7654.4	-	9455.8	-	-	-	12946.8	-	17175.9
151.7	-	2984.1	5094.2	4952.9	7988.9	-	9879.4	-	-	-	13556.6	-	17959.9
158.6	-	3110.3	5301.1	5159.8	8311.8	-	10288.2	-	-	-	14145.1	-	18716.6
165.5	-	3231.1	5498.9	5357.6	8620.5	-	10679.1	-	-	-	14707.9	-	19440.2
172.4	-	3344.3	5684.4	5543.2	8910.1	-	11045.8	-	-	-	15235.8	-	20119.0
179.3	-	3448.4	5855.0	5713.7	9176.3	-	11382.9	-	-	-	15721.1	-	20743.0
186.2	-	3539.6	6004.4	5863.2	9409.5	-	11678.2	-	-	-	16146.2	-	21289.7
193.1	-	3612.1	-	-	-	-	11913.0	-	-	-	16484.2	-	21724.2
200.0	-	-	-	-	-	-	12053.4	-	-	-	16686.4	-	21984.3
206.9	-	-	-	-	-	-	12024.3	-	-	-	16644.5	-	21930.4
213.8	-	-	-	-	-	-	11621.1	-	-	-	16064.0	-	21183.9
220.7	-	-	-	-	-	-	8521.0	-	-	-	11601.0	-	15445.4

NOTE

1. Flowing pressure is the valve set pressure plus the overpressure plus the atmospheric pressure (1014 bara).

CROSBY H-SERIES
OUTLET REACTION FORCES

OUTLET REACTION FORCES STYLES HE, HCI, HSJ

TOTAL OUTLET REACTION FORCE - kN (STYLES HE, HCI, HSJ) (continued)

Flowing press. ^[1] (bar a)	Orifice designation														
	K2	L	L	L2	M	M2	N	P	P2	P2	Q	Q2	R	R	RR
	Outlet diameter														
	6"	4"	6"	6"	6"	6"	6"	6"	6"	8"	8"	8"	8"	10"	10"
Total outlet reaction force - kN (Styles HE, HCI, HSJ)															
6.9	-	849.2	849.2	-	1071.6	-	1292.1	1899.1	-	-	3287.7	-	-	-	-
13.8	-	2228.9	1724.6	-	2176.2	-	2792.6	4973.0	-	-	8523.1	-	-	-	-
20.7	2321.7	3782.2	2754.6	3542.2	3960.1	4566.9	5155.9	8446.5	9560.0	-	14536.3	16481.0	22532.7	20683.2	25992.6
27.6	3638.5	5330.2	4302.7	5355.0	5913.6	6724.4	7511.5	11908.4	13396.3	-	20529.6	23128.1	31214.6	29365.1	36459.7
34.5	5010.3	6868.1	5840.5	7155.9	7854.0	8867.5	9851.3	15347.3	17207.2	-	26483.0	29731.0	39838.9	37989.4	46857.4
41.4	6369.9	8392.2	7364.7	8940.7	9777.2	10991.6	12170.4	18755.7	20984.1	-	32383.5	36275.3	48386.5	46536.9	57162.5
48.3	7715.1	9900.1	8872.6	10706.6	11680.0	13093.1	14464.8	22127.8	24721.0	-	38221.3	42750.0	56843.3	54993.7	67358.2
55.2	9043.9	-	10362.2	12451.1	13559.7	15169.1	16731.4	25459.0	28412.4	-	-	49146.1	65197.3	63347.8	77430.1
62.1	10354.4	-	11831.4	14171.5	15413.5	17216.5	18966.8	28744.3	32053.1	-	-	55454.1	73436.4	71586.8	87363.3
69.0	11645.1	-	13278.2	15865.8	17239.2	19232.9	21168.2	31979.9	35638.6	-	-	61666.5	81550.6	79701.1	97146.0
75.9	12751.8	-	-	17318.6	-	20961.8	-	-	38712.9	-	-	66993.3	-	86658.5	105534.1
82.8	13981.6	-	-	18933.1	-	22883.1	-	-	42129.2	-	-	72912.8	-	94390.0	114855.4
89.7	15185.7	-	-	20513.8	-	24764.2	-	-	45474.2	-	-	78708.5	-	101960.0	123981.9
96.6	16362.4	-	-	22058.6	-	26602.7	-	-	48743.3	-	-	84372.9	-	109358.3	132901.5
103.4	17425.1	-	-	23453.7	-	28262.9	-	-	51695.5	50256.9	-	89488.0	-	116039.2	140956.2
110.3	18645.6	-	-	25055.9	-	30169.6	-	-	55086.0	53647.5	-	95362.6	-	123712.3	150207.0
117.2	19850.1	-	-	26637.1	-	32051.3	-	-	58432.0	56993.4	-	101160.1	-	131284.5	159336.3
124.1	21037.8	-	-	28196.3	-	33907.0	-	-	-	60293.0	-	-	-	-	-
131.0	22204.6	-	-	29728.0	-	35729.8	-	-	-	63534.3	-	-	-	-	-
137.9	23349.0	-	-	31230.3	-	37517.6	-	-	-	66713.3	-	-	-	-	-
144.8	24465.5	-	-	32696.0	35374.1	39261.9	-	-	-	69815.0	-	-	-	-	-
151.7	25550.0	-	-	34119.8	36908.2	40956.2	-	-	-	72827.8	-	-	-	-	-
158.6	26596.6	-	-	35493.7	38388.7	42591.3	-	-	-	75735.3	-	-	-	-	-
165.5	27597.5	-	-	36807.6	39804.4	44154.9	-	-	-	78515.6	-	-	-	-	-
172.4	28536.3	-	-	38040.1	41132.4	45621.6	-	-	-	81123.7	-	-	-	-	-
179.3	29399.4	-	-	39173.1	42353.3	46970.0	-	-	-	83521.3	-	-	-	-	-
186.2	30155.5	-	-	40165.7	43422.8	48151.3	-	-	-	85621.8	-	-	-	-	-
193.1	30756.6	-	-	40954.8	44273.1	49090.4	-	-	-	87291.7	-	-	-	-	-
200.0	31116.2	-	-	41427.0	44781.8	49652.2	-	-	-	88290.8	-	-	-	-	-
206.9	31041.7	-	-	41329.1	44676.4	49535.7	-	-	-	88083.7	-	-	-	-	-
213.8	30009.3	-	-	39973.8	43216.0	47922.9	-	-	-	85215.7	-	-	-	-	-
220.7	22072.0	-	-	29554.0	31988.4	35522.6	-	-	-	63166.0	-	-	-	-	-

NOTE

1. Flowing pressure is the valve set pressure plus the overpressure plus the atmospheric pressure (1.014 bara).

CROSBY H-SERIES

OUTLET REACTION FORCE

OUTLET REACTION FORCES STYLE HSL

TOTAL OUTLET REACTION FORCE - lbs (N)

Flowing press. psig (barg)	Orifice designation									
	F	G	H	J	K	L	M	N	P	Q
	Outlet dia.									
	1½"	1½"	2½"	2½"	3"	4"	4"	6"	6"	8"
25 (1.72)	5.4 (24.0)	8.8 (39.2)	13.8 (61.6)	21.1 (94.1)	32.6 (145.1)	50.5 (224.6)	63.0 (280.5)	77.0 (342.6)	112.1 (498.6)	176.0 (783.3)
50 (3.45)	11.0 (49.1)	18.0 (80.0)	28.2 (125.6)	43.1 (192.0)	66.5 (296.0)	103.0 (458.2)	128.6 (572.2)	157.1 (699.0)	228.6 (1017.3)	359.1 (1598.0)
75 (5.17)	16.7 (74.4)	27.3 (121.4)	42.8 (190.5)	65.4 (291.2)	100.9 (449.0)	156.2 (695.0)	195.0 (867.9)	238.2 (1060.1)	346.7 (1542.9)	544.7 (2423.8)
100 (6.89)	22.5 (99.9)	38.8 (172.8)	57.5 (255.9)	87.9 (391.2)	135.9 (604.6)	209.8 (933.6)	278.7 (1240.4)	320.0 (1424.1)	465.7 (2072.6)	731.6 (3255.8)
125 (8.62)	28.2 (125.6)	55.5 (246.8)	72.3 (321.6)	123.3 (548.6)	197.4 (878.5)	281.7 (1253.6)	397.7 (1770.0)	402.2 (1789.7)	619.9 (2758.4)	919.5 (4091.8)
150 (10.34)	34.2 (152.1)	72.2 (321.1)	87.1 (387.5)	163.3 (726.8)	259.2 (1153.3)	377.3 (1678.9)	517.1 (2301.2)	484.6 (2156.5)	832.1 (3702.8)	1221.1 (5434.0)
175 (12.07)	44.4 (197.7)	88.9 (395.5)	108.1 (481.2)	203.5 (905.4)	321.1 (1428.7)	473.1 (2105.2)	636.7 (2833.5)	587.8 (2615.6)	1044.7 (4649.0)	1555.2 (6920.5)
200 (13.79)	54.7 (243.4)	105.6 (470.0)	134.4 (598.1)	243.6 (1084.2)	383.0 (1704.4)	569.0 (2531.9)	756.5 (3366.4)	734.1 (3266.5)	1257.6 (5596.4)	1889.6 (8408.7)
225 (15.51)	65.0 (289.1)	122.4 (544.6)	160.7 (715.1)	283.8 (1263.1)	445.0 (1980.2)	664.9 (2958.8)	876.3 (3899.6)	880.4 (3917.8)	1470.6 (6544.3)	2224.2 (9897.8)
250 (17.24)	75.2 (334.8)	139.1 (619.2)	187.0 (832.2)	324.1 (1442.0)	507.0 (2256.1)	760.9 (3385.9)	996.1 (4432.8)	1026.8 (4569.2)	1683.7 (7492.3)	2558.9 (11387.0)
275 (18.96)	85.5 (380.5)	155.9 (693.7)	213.3 (949.2)	364.2 (1620.9)	569.0 (2531.8)	856.8 (3812.7)	1115.9 (4966.0)	1173.1 (5220.4)	1896.6 (8440.0)	2893.4 (12875.8)
300 (20.68)	95.8 (426.2)	172.6 (768.2)	239.6 (1066.1)	404.4 (1799.7)	630.9 (2807.5)	952.7 (4239.4)	1235.7 (5498.7)	1319.4 (5871.2)	2109.5 (9387.2)	3227.8 (14363.7)
325 (22.41)	106.0 (471.8)	189.4 (842.6)	265.8 (1182.9)	444.6 (1978.3)	692.8 (3082.9)	1048.5 (4665.6)	1355.3 (6031.1)	1465.5 (6521.4)	2322.1 (10333.5)	3561.9 (15850.3)
350 (24.13)	116.3 (517.4)	206.1 (917.0)	292.1 (1299.6)	484.7 (2156.7)	754.6 (3357.9)	1144.1 (5091.4)	1474.8 (6562.8)	1611.5 (7171.0)	2534.6 (11278.8)	3895.6 (17335.3)
375 (25.86)	126.5 (562.9)	222.7 (991.2)	318.2 (1416.2)	524.7 (2334.9)	816.3 (3632.6)	1239.7 (5516.6)	1594.1 (7093.8)	1757.2 (7819.6)	2746.7 (12222.8)	4228.8 (18818.2)
400 (27.58)	136.7 (608.4)	239.4 (1065.4)	344.4 (1532.5)	564.7 (2512.7)	878.0 (3906.9)	1335.1 (5941.2)	1713.3 (7624.0)	1902.7 (8467.2)	2958.5 (13165.4)	4561.5 (20298.9)
425 (29.30)	146.9 (653.7)	256.0 (1139.4)	370.5 (1648.7)	604.6 (2690.4)	939.5 (4180.7)	1430.4 (6365.1)	1832.2 (8153.4)	2048.0 (9113.8)	3170.0 (14106.4)	4893.7 (21777.2)
450 (31.03)	157.1 (699.0)	272.6 (1213.2)	396.6 (1764.7)	644.4 (2867.6)	1000.9 (4454.1)	1525.4 (6788.2)	1950.9 (8681.7)	2193.1 (9759.1)	3381.0 (15045.6)	5225.3 (23252.6)
475 (32.75)	167.2 (744.2)	289.2 (1287.0)	422.6 (1880.4)	684.2 (3044.5)	1062.2 (4726.8)	1620.3 (7210.4)	2069.4 (9208.9)	2337.8 (10403.2)	3591.7 (15983.0)	5556.2 (24725.1)
500 (34.47)	177.4 (789.3)	305.7 (1360.5)	448.5 (1995.9)	723.8 (3221.1)	1123.4 (4999.1)	1715.0 (7631.7)	2187.7 (9735.2)	2482.2 (11046.0)	3801.9 (16918.5)	5886.4 (26194.6)
525 (36.20)	187.5 (834.3)	322.2 (1433.9)	474.4 (2111.1)	763.4 (3397.3)	1184.4 (5270.7)	1809.5 (8052.2)	2305.7 (10260.2)	2626.4 (11687.3)	4011.7 (17851.9)	6215.9 (27660.9)
550 (37.92)	197.6 (879.2)	338.7 (1507.2)	500.2 (2226.1)	802.9 (3573.0)	1245.3 (5541.7)	1903.7 (8471.6)	2423.4 (10784.0)	2770.1 (12327.1)	4220.9 (18783.1)	6544.7 (29123.7)
575 (39.64)	207.6 (924.0)	355.1 (1580.3)	526.0 (2340.7)	842.3 (3748.3)	1306.1 (5811.9)	1997.8 (8890.0)	2540.8 (11306.5)	2913.6 (12965.3)	4429.7 (19711.9)	6872.6 (30582.9)
600 (41.37)	217.7 (968.7)	371.5 (1653.1)	551.7 (2455.1)	881.6 (3923.1)	1366.6 (6081.5)	2091.5 (9307.2)	2657.9 (11827.6)	3056.6 (13601.8)	4637.8 (20638.2)	7199.5 (32038.0)
625 (43.09)	227.7 (1013.2)	387.8 (1725.8)	577.3 (2569.2)	920.8 (4097.6)	1427.1 (6350.4)	2185.1 (9723.5)	2774.7 (12347.4)	3199.3 (14236.8)	4845.5 (21562.4)	7525.8 (33489.8)
650 (44.82)	237.7 (1057.6)	404.1 (1798.3)	602.9 (2682.9)	959.9 (4271.5)	1487.3 (6618.6)	2278.3 (10138.6)	2891.2 (12865.7)	3341.6 (14869.9)	5052.6 (22483.9)	7851.1 (34937.3)
675 (46.54)	247.6 (1101.9)	420.3 (1870.5)	628.4 (2796.3)	998.8 (4444.8)	1547.4 (6885.9)	2371.3 (10552.3)	3007.3 (13382.4)	3483.4 (15501.1)	5259.0 (23402.4)	8175.3 (36380.2)
700 (48.26)	257.5 (1146.1)	436.5 (1942.6)	653.8 (2909.4)	1037.7 (4617.7)	1607.3 (7152.4)	2464.0 (10964.9)	3123.1 (13897.7)	3624.8 (16130.5)	5464.8 (24318.5)	8498.7 (37819.2)
725 (49.99)	267.4 (1190.1)	452.7 (2014.4)	679.1 (3022.2)	1076.4 (4790.1)	1667.0 (7418.2)	2556.5 (11376.3)	3238.5 (14411.4)	3765.8 (16757.9)	5670.0 (25231.6)	8821.1 (39253.8)

Total resultant force at outlet elbow²

The figure (right) shows a safety valve open and discharging at full capacity, with a 90° outlet elbow. The horizontal reaction force (F_h) is balanced by the force of discharging steam acting on the 90° elbow.

The vertical force (F_v) at the 90° elbow is unbalanced and exerts a bending moment on the valve. Vertical force (F_v) is the resultant of the reaction due to velocity and the static pressure of the steam acting on the area of the elbow when the valve is open and discharging.

NOTES

1. Flowing pressure is the valve set pressure plus the overpressure plus the atmospheric pressure (14.7 psia) in psia or bara.
2. Determination of outlet reaction forces is the responsibility of the designer of the vessel and/or piping.

The basic equation for this is:

$$F_v = \frac{WV + (AP_e)}{g_c}$$

where:

- F Vertical force
- W Flow in lbs/sec
- V Velocity, ft/sec
- A Area of outlet, sq. in.
- P_e Static pressure in outlet elbow, psia
- g_c Gravitational constant

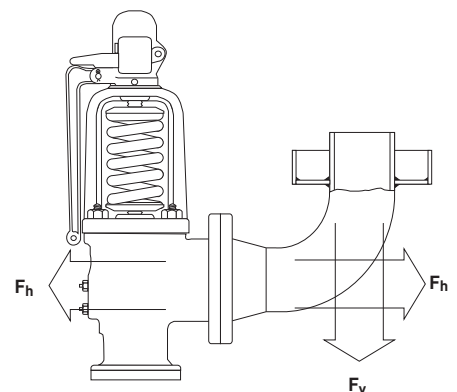

CROSBY H-SERIES

OPTIONAL EQUIPMENT

OPTIONAL EQUIPMENT

Drip pan elbows

For optimum safety valve performance, discharge piping should be supported independently of the valve. This can best be accomplished by installing a slip joint arrangement at the inlet to the riser pipe, using a drip pan elbow.

The riser should be sized sufficiently larger than the slip joint to provide clearance during expansion of the boiler and should be located with enough clearance at the lower end to prevent 'bottoming' on the drip pan.

Drain lines should be installed from the discharge elbow and the safety valve body and piped separately from any other drain or vent line. The size of the drip pan elbow should be at least equal to that of the safety valve outlet. The flanged Model EFS drip pan elbow should be used without any intermediary connection.

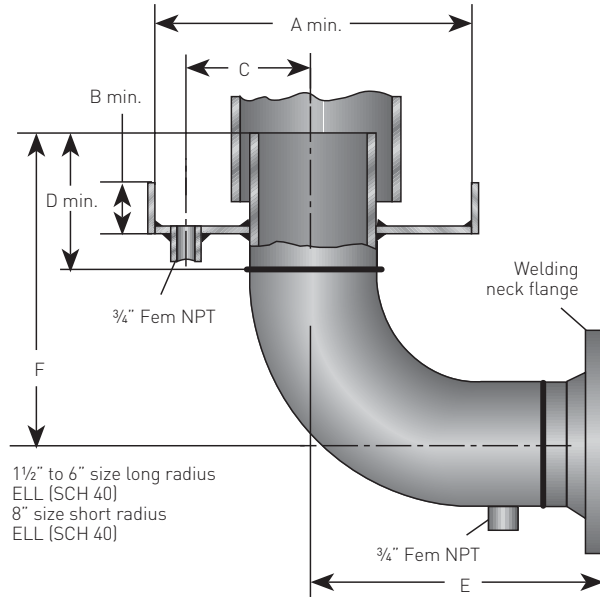

Specifications

- Model:** EFS
- Sizes:** 1½", 2", 2½", 3", 4", 6", 8" and 10"
- Flange**
- ANSI class:** 150 (1½" to 10")
300 (3" to 10")
600 (3")
- Material:** Carbon steel

DIMENSIONS - inches

Valve outlet size	A		B		C		D		E		E		E		F	
	in	(mm)	in	(mm)	in	(mm)	in	(mm)	150 ANSI class	300 ANSI class	600 ANSI class	in	(mm)	in	(mm)	
1½	8.5	(215.9)	2½	(63.5)	3	(76.2)	6	(152.4)	5½	(139.7)	-	-	-	-	8½	(215.9)
2	9	(228.6)	2½	(63.5)	3	(76.2)	6	(152.4)	5½	(139.7)	-	-	-	-	9	(228.6)
2½	9	(228.6)	2½	(63.5)	3	(76.2)	7	(177.8)	6½	(165.1)	-	-	-	-	10¾	(273.0)
3	9	(228.6)	3	(76.2)	3	(76.2)	8	(203.2)	7¼	(184.1)	7⅞	(193.7)	8	(203.2)	12½	(317.5)
4	12	(304.8)	3	(76.2)	4	(101.6)	8	(203.2)	9	(228.6)	9⅞	(238.1)	-	-	14	(355.6)
6	14	(355.6)	4	(101.6)	5	(127.0)	8	(203.2)	12½	(317.5)	12⅞	(327.0)	-	-	17	(431.8)
8	16	(406.4)	4	(101.6)	6½	(165.1)	8	(203.2)	12	(304.8)	12⅞	(314.3)	-	-	16	(406.4)
10	20	(508.0)	5	(127.0)	8	(203.2)	10	(254.0)	14	(355.6)	14⅞	(371.5)	-	-	20	(508.0)

CROSBY H-SERIES

OPTIONAL EQUIPMENT

Weatherhoods

Safety valves for outdoor installations should be supplied with weatherhoods to protect the exposed spring and upper structure from weather and thermal effects. They are available for all series H valves.

Reseating machines

Reseating machines will remachine the nozzle seats in place without removing the safety valve from the installation. Form cutters are used to cut a new seat to exact dimensions. Reseating machines, cutters and auxiliary equipment may be rented or purchased.

Jacking devices

When a safety valve is to be disassembled, the spring compression, i.e. the set pressure, can be retained by use of a mechanical or hydraulic jacking device. These are used to lift the lower spring washer sufficiently to allow the disc insert to lift clear of the nozzle, permitting the entire bonnet assembly to be removed. Jacking devices may be rented or purchased.

Air (ASPD) and hydraulic (HSPD) set pressure devices

The set pressure of safety valves can be determined without raising system pressure to the popping pressure of the valves by using a set pressure device, which may be rented or purchased.

The apparatus consists of a lifting device mounted on the bonnet and connected to the spindle of the safety valve. The differential force, required to open the safety valve when the system (steam) pressure is less than the valve set pressure, is applied by the operator. The differential force at which the valve opens is determined and the set pressure is calculated from this measurement.

For details of all the optional equipment available, contact your local sales representative.

Also available:

- Lapping blocks
- Lapping block resurfacing plates

WEATHERHOOD

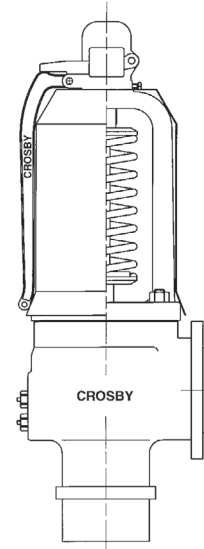

RESEATING MACHINE



CROSBY H-SERIES

ORDERING INFORMATION

ORDERING INFORMATION

H Series safety valves are for steam service on steam generators, unfired pressure vessels and pipe lines. To assist customers in selecting the right safety valves to suit a specific application, Crosby will recommend the most suitable safety valve, size and style. To enable us do this, the following information is required:

Steam generators

- Type
- Service
- Valve inlet (welded or flanged)
- Maximum rate of steam generation
- Design pressure
- Drum operating pressure
- Superheater outlet temperature
- Superheater outlet operating pressure
- Reheater steam flow (if any)
- Reheater inlet operating pressure
- Reheater inlet temperature
- Reheater outlet operating pressure
- Reheater outlet temperature
- Applicable code (ASME Section I or Section VIII)
- Indicate if for outdoor service

Unfired pressure vessel service

- Required capacity
- Design pressure of vessel
- Operating pressure
- Maximum operating temperature
- Applicable code

Existing boilers

- Design pressure (or maximum allowable working pressure if below design pressure)
- Maximum operating pressure (drum and superheater)
- Maximum rate of steam generation or heating surface and type of firing
- Number and size of openings for safety valves (if special flanges - diameter of bolt circle, number and size of holes)

Organic fluid vaporizer (Dowtherm) service

- Name of fluid
- Molecular weight or specific gravity
- Required capacity lbs/hr of organic fluid

For customers who wish to size their own safety valves, orders should include the following data:

Data	Example
Code requirements	ASME Section I
Quantity of valves	Two
Size - inlet x orifice x outlet	2½" x K2 x 6"
Style	HCI-46W
Set pressure	1 at 1150 psig (79 barg) 1 at 1200 psig (83 barg)
Required capacity (total) (or indicate actual valve capacity)	280,000 lbs/hr (127,000 kg/hr) (Total)
Temperature - saturated or °F [°C]	Saturated
Maximum operating pressure	
Drum	1000 psig (69 barg)
Superheater	None
Connections (rating and facing)	Buttweld inlet ANSI CL 150 outlet - RF

CROSBY H-SERIES

ORDERING INFORMATION

SELECTION GUIDE - Style HE ISOFLEX®

Example:	2½ K 6	HE	-W	-8	6	-C
Size (Inlet x orifice x outlet)						
2½ K 6 to 4 P2 8						
Valve series						
HE		HE ISOFLEX® High capacity safety valve				
Inlet connection type⁽¹⁾						
None		Flanged inlet connection				
-W		Butt weld inlet connection				
Pressure rating						
-8		2500 psig maximum pressure (172 barg)				
-9		3000 psig maximum pressure (207 barg)				
Temperature limit / body material						
6		750°F / SA216 WCC (399°C)				
Cap and lifting lever type						
-C		(Standard) Regular lifting lever				

NOTES

- Welded inlets are standard for HE valves.
For optional 2500# flanged inlet valves, the 'W' is dropped from model #.

Model # examples:

- 2½ K 6 HE-W-86-C
- 3 M2 6 HE-W-96-C
- 4 P2 8 HE-W-86-C

SELECTION GUIDE - Style HCI ISOFLEX®

Example:	3 M2 6	HCI	-8	6	W	-C
Size (Inlet x orifice x outlet)						
1½ H2 3 to 6 RR 10						
Valve series						
HCI		HCI ISOFLEX® High capacity safety valve				
HCI-R		HCI ISOFLEX® Restricted lift high capacity safety valve				
Pressure rating						
-3		ANSI CL 300 inlet				
-4		ANSI CL 600 inlet				
-5		ANSI CL 900 inlet				
-6		ANSI CL 1500 inlet				
-7		ANSI CL 900 inlet (ANSI CL 300 outlet)				
-8		ANSI CL 1500 inlet (ANSI CL 300 outlet)				
-9		ANSI CL 2500 inlet				
Temperature limit / body material						
6		750°F / SA216 WCC (399°C)				
8		1050°F / SA217 WC6 (566°C)				
9		1100°F / SA217 WC9 (594°C)				
-C12A		1130°F / SA217 C12A (610°C)				
Inlet connection type⁽¹⁾						
None		Flanged inlet connection				
W		Butt weld inlet connection				
Cap and lifting lever type						
-C		(Standard) Regular lifting lever				

NOTES

- Welded inlets are standard for HCI valves.
For optional flanged inlet valves, the 'W' is dropped from model #.

Model # examples:

- 3 M2 6 HCI-79W-C
- 2 J2 4 HCI-R-46-C
- 1½ H2 4 HCI-86W-C

CROSBY H-SERIES

ORDERING INFORMATION

SELECTION GUIDE - Style HSJ

Example:	1½ F 2	HSJ	-4	6	-C
Size (Inlet x orifice x outlet)					
1½ F 2 to 6 Q 8					
Valve series					
HSJ					
HSJ High capacity safety valve					
HSJ-DOW					
HSJ High capacity safety valve for Dowtherm service					
HSJ-ECO					
HSJ High capacity safety valve for economizer service					
Pressure rating					
-1					
ANSI CL 150 inlet					
-2					
ANSI CL 300 inlet					
-3					
ANSI CL 300 inlet (2J3 only)					
-4					
ANSI CL 600 inlet ⁽²⁾					
-5					
ANSI CL 900 inlet					
-6					
ANSI CL 1500 inlet					
-7					
ANSI CL 2500 inlet					
Temperature limit / body material					
6					
750°F / SA216 WCC (399°C)					
7					
1000°F / SA217 WC6 ⁽¹⁾ (538°C)					
Cap and lifting lever type					
-A					
Threaded cap (restricted height)					
-C					
(Standard) Regular lifting lever					
-D					
Packed lifting lever					
-E					
Packed lifting lever with test rod					
-T					
Lifting lever with test gag					

NOTES

- SA217 WC6 is Crosby's standard high temperature material. SA-217 WC9 is available as an alternative
- Orifices F and G with a '-4' pressure rating set below 600 psig (41.4 barg) have an ANSI CL 300 inlet flange.

Model # examples:

- 1½ F 2 HSJ-46-C
- 3 J 4 HSJ-67-C
- 3 M 6 HSJ-DOW-36-D

SELECTION GUIDE - Style HSL

Example:	2½ L 4	HSL	-3	8	-C
Size (Inlet x orifice x outlet)					
1¼ F 1½					
1¼ G 1½					
1½ H 2½					
1½ J 2½					
2 K 3					
2½ L 4					
3 M 4					
4 N 6					
4 P 6					
6 Q 8					
Valve series					
HSL					
HSL High capacity flanged steel safety valve					
Inlet flange rating					
-3					
300#					
-4					
600#					
Temperature limit / body material					
6					
750°F / SA216 WCB (399°C)					
8					
1000°F / SA217 WC6 (538°C)					
Cap and lifting lever type					
-C					
(Standard) Regular lifting lever					

Available options

Accessories

- Test gag
- Weatherhood
- CL 150# Drip pan elbow

Other

- Ring type joint (RTJ) inlet

Model # examples:

- 2½ L 4 HSL-38-C
- 6 Q 8 HSL-46-C

CROSBY H-SERIES

ORDERING INFORMATION

SELECTION GUIDE - STYLE HCA-I

Example:	3 M2 8	HCA	-I	-W	-118	-C12A	-C	-TS
Size (Inlet x orifice x outlet)								
2½ K 6 to 3 M2 8								
Valve series								
HCA		HCA Supercritical safety valve						
Disc design								
-I			Isoflex design					
Inlet connection type⁽¹⁾								
-W				Butt weld inlet connection				
Pressure rating								
-118					Butt weld inlet x ANSI CL 300 outlet			
Temperature limit / body material								
None								
-C12A						1120°F / SA217 C12A (604°C)		
Cap and lifting lever type								
-C							(Standard) Regular lifting lever (test gag is included)	
Model number supplements⁽¹⁾								
None								No model # supplements
P								CE / PED certification
TS								China TS manufacturing license

NOTES

1. Include '-' if model # supplement(s) apply.

Model # examples:

- 3 M2 8 HCA-I-W-118-C12A-C
- 2.5 K2 6 HCA-I-W-118-C
- 2.5 K2 6 HCA-I-W-118-C-TS

Available options

- Weatherhood
- Limit switch
- Materials of construction for applications above 1120°F/604°C

CROSBY H-SERIES

INSTALLATION RECOMMENDATIONS

SAFETY VALVE INSTALLATION RECOMMENDATIONS

Safety valves are intended to open and close within a narrow pressure range; therefore, valve installations require careful and accurate design both as to inlet and discharge piping. The higher the operating pressure and the greater the valve capacity, the more critical becomes the need for proper design of the installation. (ASME/ANSI power piping code B31.1).

Inlet piping^[1]

Safety valves should always be mounted in a vertical position directly on nozzles having a well rounded approach that provides smooth, unobstructed flow from the vessel or line to the valve. A safety valve should NEVER be installed on a nozzle with an inside diameter smaller than the inlet connection to the valve or on excessively long nozzles.

The pressure drop occurring in the inlet piping between the valve and pressure source should be computed at actual flow of the valve, bearing in mind that the ASME boiler code, Section I rating for safety valves is only 90% of the actual flow. The safety valve or safety relief valve(s) should be connected to the boiler independently of any other connection and attached as close as possible to the boiler or the normal steam flow path without any unnecessary intervening pipe or fitting. Any intervening pipe or fitting should be no longer than the face-to-face dimension of the corresponding tee fitting of the same diameter and pressure under the applicable American national standard. The wall thickness of the inlet piping must be heavy enough to resist bending moments due to reaction when the valve discharges.

Outlet reaction forces

The forces created by the steam discharging from a safety valve will impose a reactive load on the inlet of the valve, the mounting nozzle and the adjacent supporting vessel.

The precise nature of the loading and the resulting stresses will depend on the configuration of the valve and the discharge piping. This must be taken into consideration by those responsible for the installation of the safety valve and associated vessel or piping. Determination of outlet reaction forces is the responsibility of the vessel and/or piping designer (see pages 78-82).

Boilers

It is recommended that the absolute minimum differential pressure, i.e. the pressure between the valve set pressure and operating pressure, is not less than 5% to ensure seat tightness. Nozzles for safety valves on boiler steam drums must have inside diameters equal to the valve nominal size. Nominal diameter plus 1/2" (15 mm) or more is recommended, particularly for valves mounted off the center line of the drum.

Pipe lines

Where safety valves are installed to protect a piping system, as on the low pressure side of a reducing valve or on a turbine bypass, the pipe or header must be of sufficient size to maintain flow under the safety valve while it is discharging. On a pressure reducing valve installation, the safety valves should be located at least eight pipe diameters downstream from the pressure reducing valve. Where nozzles are used, they must be as short as possible, preferably one pipe size larger than the valve inlet and designed to counterbalance the reaction when the valve discharges. Several smaller valves are better than one large valve and the set pressure of each valve should be staggered within ASME boiler and pressure vessel code limitations.

1. Request paper by J.R. Zahorsky titled: 'Degradation of pressure relief valve performance caused by inlet piping configuration'.

CROSBY H-SERIES

INSTALLATION RECOMMENDATIONS

Discharge piping^[2]

The discharge piping from safety valves should be equal in size to, or larger than, the nominal valve outlet and should be as simple and direct as possible.

Connections with generous clearances are preferred. The discharge pipe above the drip pan should be sized adequately to avoid 'blow back' of steam from around the drip pan into the boiler room when the valve is discharging. Where piping extends to a considerable length, it may be necessary to increase the pipe size at the upper part of the stack.

Where flexible hose connections are used in place of or in conjunction with drip pans, they must be of sufficient length and flexibility to absorb expansion and impose no strains on the valve outlet when the pressure vessel is at normal operating pressure.

Where solid piping must be used, expansion bends should be employed for the same purpose.

Headers

On superheater and reheater headers, inlet nozzle connections for safety valves should be as short as possible. Piping nozzles should have a rounded entrance and larger ID than the valve nominal size. This is often necessary to keep the inlet pressure drop within limits. Such connections should be away from turns or branches, which can cause turbulence. The exit from the header or riser should be larger than the valve inlet, have a well rounded approach and a uniform reduction of diameter with no abrupt changes, preferably with a smooth, gradual taper (similar to a seamless reducing or Y fitting). The design should also result in minimum pressure drop from the header or riser to the safety valve.

- Design considerations are included in the following articles: 'Steam flow through safety valve vent pipes' by H.E. Brandmaier and M.E. Knebel (December 1975), 'Analysis of power plant safety and relief valve vent stacks' by G.S. Liao (November 1974), and 'Safety valve vent pipe sizing for open discharge systems' by J.W. Sale (June 1979). The latter papers are ASME publications.

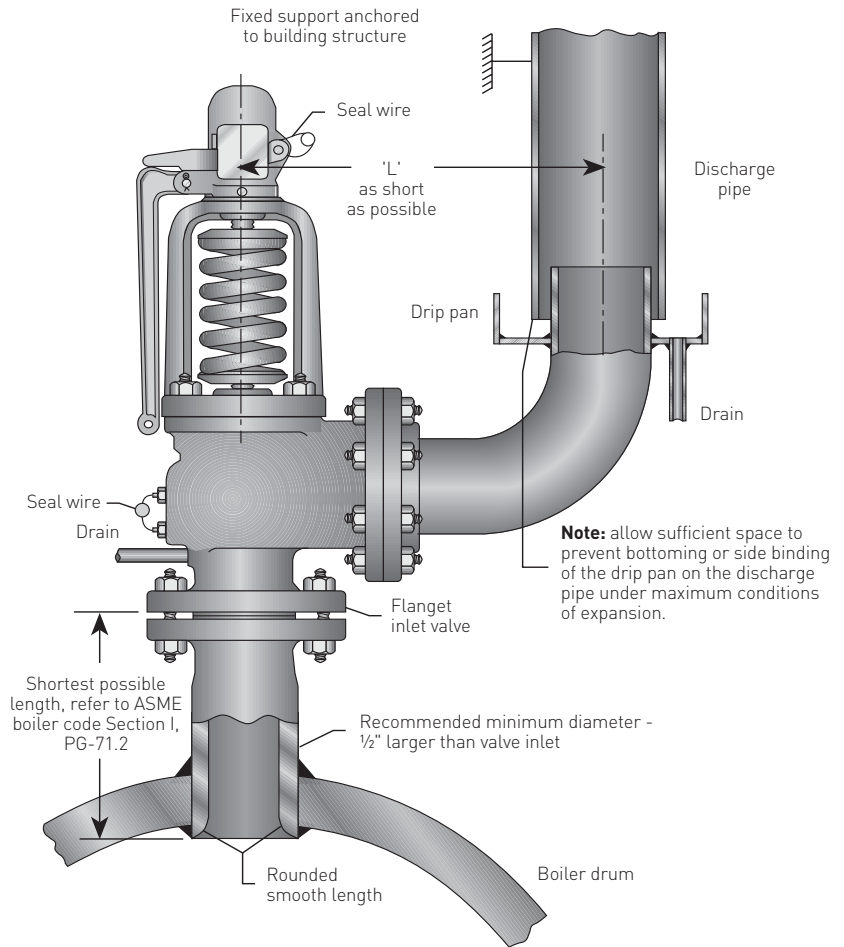

CROSBY H-SERIES

INSTALLATION RECOMMENDATIONS

Discharge manifolds

Discharge manifold lines are satisfactory if the following 'good practices' are observed: The area of the manifold should be equal to or larger than the areas leading into it. 'Stepping up' the size of the manifold at each point where another valve discharge line enters permits smoother flow than simply sizing the manifold to the total area required. The manifold should be supported independently and not on the valves. The same precautions should be observed in providing drip pans, flexible connections and expansion bends on the individual discharge valve lines leading into the manifold. The manifold should be anchored adequately to prevent it from swaying and with adequate drains provided.

The discharge lines should be led into the manifold at an angle of 45° (less if possible) to the direction of the steam flow. The manifold should be checked for possible back pressure which might cause steam 'blow back' out of individual drip pans. If closed systems are used, back pressure in the manifold resulting when one valve discharges can affect the popping point and the performance of other valves connected to the same system.

Note: all piping in the discharge system must be vented to a safe disposal area to prevent personnel injury when the valve discharges.

Drains

Provisions for drains are located in the valve bodies and should be piped to a drainage system to remove condensate. Separate drains are recommended to drain the drip pan and on certain types of installations additional drainage from the discharge piping may be provided. This is especially true in marine installations where it is essential that the main atmospheric exhaust stack is provided with a drain pocket at the lowest point and that a separate drain line is carried from this pocket to the bilge.

Note: all drains and piping in the discharge system must be piped to a safe disposal area to prevent possible personnel injury when the valve discharges.

Hydrostatic testing of boilers

Hydrostatic test plugs are recommended for use on welded inlet valves. If flanged inlet valves are to be installed, we recommend that the hydrostatic test is completed prior to installing the safety valve by blanking off the boiler opening. A hydrostatic test plug is supplied for all welded inlet valves. Hydrostatic test plugs can be supplied on request for any flanged inlet safety valve.

Please consult the Crosby technical literature for details on the specific type and use of hydrostatic equipment available.

TEST CLAMPS

STYLE HE ISOFLEX AND HCI ISOFLEX

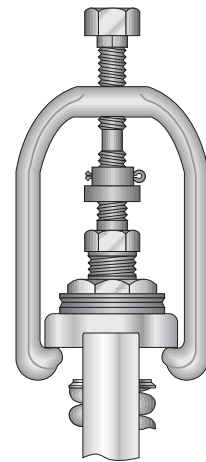

STYLE HSJ

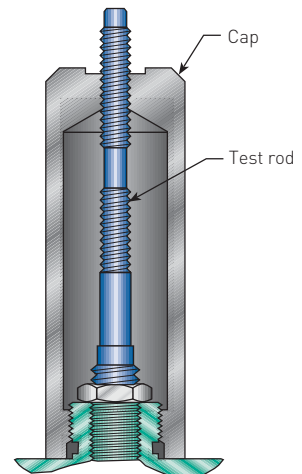

HYDROSTATIC TEST PLUG

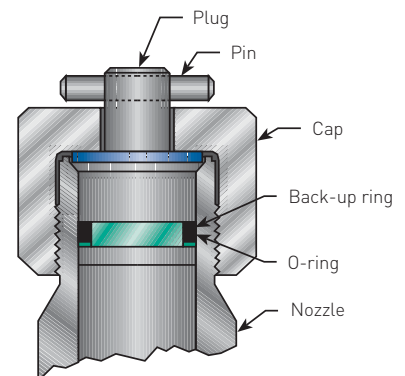

CROSBY H-SERIES

PRESSURE RELIEF DEVICE SIZING AND SELECTION SOFTWARE



Emerson PRV2SIZE incorporates over 135 years of experience and engineering expertise for an extensive array of Anderson Greenwood, Crosby and Varec pressure relief devices and related products in one software package. With Emerson PRV2SIZE customers and engineers can address numerous applications in a single sizing and selection platform without the need to use two or more sizing programs.

Emerson PRV2SIZE features:

- Improved user interface
 - Sizing calculations can be saved at any point
 - Multiple tags can be opened at one time
- Capability of sorting data using a variety of parameters
- Fully configured product selection
- Industry standard sizing methodologies
- Drop-down boxes allow instantaneous change of sizing methodology from API to ASME and vice versa
- Addition of 2:1 elliptical head tanks for fire sizing applications
- Catalog integration from existing product literature PDF's
- Detailed product specifications including cross sectional drawings with dimensions and weights - U.S. Customary System and Metric units
- Improved tools to export and import device tag numbers with the ability to mail files directly from the software program
- Combination device, reaction force and noise level calculations
- Addition of flow curves for pressure and vacuum relief valves
- Individual capsule summaries of each product including an image of the selected product

Another unique feature of Emerson PRV2SIZE is its capability to provide sizing and selection for tank protection and tank blanketing products in a single software program. This includes pad and de-pad valves, tank blanketing regulators, pressure/vacuum vents and low pressure pilot operated relief valves.

Emerson PRV2SIZE website: valvesizing.emerson.com

Neither Emerson, Emerson Automation Solutions, nor any of their affiliated entities assumes responsibility for the selection, use or maintenance of any product. Responsibility for proper selection, use, and maintenance of any product remains solely with the purchaser and end user.

Crosby is a mark owned by one of the companies in the Emerson Automation Solutions business unit of Emerson Electric Co. Emerson Automation Solutions, Emerson and the Emerson logo are trademarks and service marks of Emerson Electric Co. All other marks are the property of their respective owners.

The contents of this publication are presented for informational purposes only, and while every effort has been made to ensure their accuracy, they are not to be construed as warranties or guarantees, express or implied, regarding the products or services described herein or their use or applicability. All sales are governed by our terms and conditions, which are available upon request. We reserve the right to modify or improve the designs or specifications of such products at any time without notice.

Emerson.com/FinalControl