



North American
Safety Valve
Industries, Inc.



35,000 Safety & Relief Valves
Ready to Ship

When the pressure is on, trust North American Safety Valve Industries

We're Always on Standby

When you're under pressure, NASVI's ready to help.

New & Remanufactured Safety Valves

Extensive stock of new valves from trusted, top manufacturers and dependable remanufactured valves back by a 2-year warranty.

Same or Next-Day Shipping

Avoid or minimize downtime with NASVI's same or next-day shipping.

State-of-the-Art Repair & Setting Centers

Nearly every safety valve's specifications are at our technicians' fingertips for exact work. Generally, irreparable valves can be replaced from our in-stock inventory.

Turnaround Exchange Program

Receive the valves needed for installation prior to shutting down, then ship us the old valves for repair or exchange.

Get an Instant Quote

nasvi.com/quote

1600 Warren St.
North Kansas City, MO 64116

Phone: (800) 800-8882

Phone: (816) 421-7042

Fax: (816) 421-0297

sales@nasvi.com

spec sheet

Consolidated* **1700 Series** Safety Valve



Table of Contents

Scope of Design	2
Materials	8
Dimensions and Weights (USCS).....	19
Dimensions & Weights (Metric)	26
Pressure/Temperature (USCS)	32
Pressure/Temperature (USCS) Alternate	37
Orifice Capacities.....	42
Hydrostatic Test Plugs.....	67

Scope of Design

Example

Flanged inlet safety valve, ASME Code Section I.
Application. Set pressure 1000 psig, temperature 900°F,
required relieving capacity 94,900 lbs./hr. = valve type
number 1736D-2-S.

1. Refer to capacity table on page 1700.45 for ASME Code Section I Saturated Steam. At 1000 psig set pressure, select a #3 orifice with a saturated capacity of 120,221 lbs./hr. = valve type number 1736D-2-S.
2. Correct for superheat using table on page 1700.66 for superheat correction factor at 3% overpressure. At 1044.7 psia and 900°F, multiply saturated capacity 120,221 lbs./hr. by correction factor .797 = 95,923 lbs./hr.
3. Verify pressure and temperature requirements on page 1700.33 for ASME Section I, ASME B16.34. At 1000 psig, 900°F and a #3 orifice, locate the D temperature class and select the 900 class valve with 900# inlet flange and a 150# outlet flange = valve type number 1736 D-2-S.
4. Locate the valve type in the appropriate scope of design section page 3 and the configuration code on page 68. Complete the valve selection = valve type number 1736D-2-S-I9-F1.
5. Review the required weights, dimensions, materials and connections on page 9 and 20.

Subcritical & Supercritical Steam Service

				Valve Sizes										End Connections		
				1-1/2"	2"	2-1/2"	3"	3"	4"	4"	6"	6"	6"			6"
Pressure Class	Temperature Limits		Temp. Class	Orifice Area Sq. In.										Inlet	Outlet	
	Degrees F	Degrees C		0.994	1.431	2.545	3.341	3.976	7.07	12.25	11.05	14.18	16.00			19.29
	Orifice Designation															
				1	2	3	5	4	6	Q	Q	8	R	RR		
600	750	399	B	1715B	1725B	1735B	1755B	174B5	1765B	1775QB	1775QB	1785B	1705RB	1705RRB	Class 600 raised face or buttweld	Class 150 or 300 raised face
	1020	549	D	1715D	1725D	1735D	1755D	1745D	1765D	1775QD	1775QD	1785D	1705RD	1705RRD		
	1060	571	E	1715E	1725E	1735E	1755E	1745E	1765E	1775QE	1775QE	1785E	1705RE	1705RRE		
	1100	593	F	-	-	-	-	-	1765F	1775F	1775F	1785F	-	-		
	1120	604	G	-	-	-	-	-	1765G	1775G	1775G	1785G	-	-		
900	750	399	B	1716B	1726B	1736B	1756B	1746B	1766B	1776QB	1776QB	1786B	1706RB	1706RRB	Class 900 raised face or buttweld	Class 150 or 300 raised face
	1020	549	D	1716D	1726D	1736D	1756D	1746D	1766D	1776QD	1776QD	1786D	1706RD	1706RRD		
	1060	571	E	1716E	1726E	1736E	1756E	1746E	1766E	1776QE	1776QE	1786E	1706RE	1706RRE		
	1100	593	F	-	-	-	-	-	1766F	1776F	1776F	1786F	-	-		
	1120	604	G	-	-	-	-	-	1766G	1776G	1776G	1786G	-	-		
1500	750	399	B	1717B	1727B	1737B	1757B	1747B	1767B	-	1777QB	1787B	1707RB	1707RRB	Class 1500 raised face or buttweld	Class 150 or 300 raised face
	1020	549	D	1717D	1727D	1737D	1757D	1747D	1767D	-	1777QD	1787D	1707RD	1707RRD		
	1060	571	E	1717E	1727E	1737E	1757E	1747E	1767E	-	1777QE	1787E	1707RE	1707RRE		
	1100	593	F	-	-	-	-	-	1767F	-	-	-	-	-		
	1120	604	G	-	-	-	-	-	1767G	-	-	-	-	-		
2500	750	399	B	1719B	1729B	1739B	1759B	1749B	-	-	-	-	-	-	Class 2500 raised face or buttweld	Class 300 raised face
	1020	549	D	1719D	1729D	1739D	1759D	1749D	-	-	-	-	-	-		
	1060	571	E	1719E	1729E	1739E	1759E	1749E	-	-	-	-	-	-		
	1100	593	F	1719F	1729F	1739F	1759F	1749F	-	-	-	-	-	-		
	1120	604	G	1719G	1729G	1739G	1759G	1749G	-	-	-	-	-	-		
	1120	604	H	1719H	1729H	1739H	1749H	1759H	1769H	-	-	-	-	-		
3000	750	399	B	1710WB	1720WB	1730WB	1750WB	1740WB	1760WB	-	-	-	-	-	Class 3000 buttweld	Class 300 raised face
	1020	549	D	1710WD	1720WD	1730WD	1750WD	1740WD	1760WD	-	-	-	-	-		
	1060	571	E	1710WE	1720WE	1730WE	1750WE	1740WE	1760WE	-	-	-	-	-		
	1100	593	F	1710WF	1720WF	1730WF	1750WF	1740WF	-	-	-	-	-	-		
	1120	604	G	1710WG	1720WG	1730WG	1750WG	1740WG	-	-	-	-	-	-		
4500	750	399	B	1713WB	1723WB	1733WB	1753WB	1743WB	-	-	-	-	-	-	Class 4500 buttweld	Class 300 raised face
	1020	549	D	1713WD	1723WD	1733WD	1753WD	1743WD	-	-	-	-	-	-		
	1060	571	E	1713WE	1723WE	1733WE	1753WE	1743WE	-	-	-	-	-	-		

Scope of Design (Contd.)

Flanged Inlet – Type 17_5, class 600

Inlet ^{3&5} ANSI Std. R.F. Flange		Outlet ² ANSI Std. R.F. Flange		Type Numbers Maximum Temperature ¹			Orifice		Designation
Size	Class	Size	Class	750°F (399°C)	1020°F (549°C)	1060°F (571°C)	in ²	cm ²	
1-1/2"	600	3"	150	1715B	1715D	1715E	.994	6.413	1
2"	600	3"	150	1725B	1725D	1725E	1.431	9.232	2
2-1/2"	600	6"	150	1735B	1735D	1735E	2.545	16.420	3
3"	600	6"	150	1755B	1755D	1755E	3.341	21.556	5
3"	600	6"	150	1745B	1745D	1745E	3.976	25.653	4
4"	600	6"	150	1765B	1765D	1765E	7.070	45.616	6
4"	600	8"	150	1775QB	1775QD	1775QE	12.25	79.037	Q
6"	600	8"	150	1775QB	1775QD	1775QE	11.050	71.295	Q
6"	600	8"	150	1785B	1785D	1785E	14.180	91.489	8
6"	600	8"	150	1705RB	1705RD	1705RE	16.000	103.232	R
6"	600	8"	150	1705RRB	1705RRD	1705RRE	19.29	124.459	RR

Flanged Inlet – Type 17_6, class 900

Inlet ^{4&5} ANSI Std. R.F. Flange		Outlet ² ANSI Std. R.F. Flange		Type Numbers Maximum Temperature ¹			Orifice		Designation
Size	Class	Size	Class	750°F (399°C)	1020°F (549°C)	1060°F (571°C)	in ²	cm ²	
1-1/2"	900	3"	150	1716B	1716D	1716E	.994	6.413	1
2"	900	3"	150	1726B	1726D	1726E	1.431	9.232	2
2-1/2"	900	6"	150	1736B	1736D	1736E	2.545	16.420	3
3"	900	6"	150	1756B	1756D	1756E	3.341	21.556	5
3"	900	6"	150	1746B	1746D	1746E	3.976	25.653	4
4"	900	6"	150	1766B	1766D	1766E	7.070	45.616	6
4"	900	8"	150	1776QB	1776QD	1776QE	12.25	79.037	Q
6"	900	8"	150	1776QB	1776QD	1776QE	11.050	71.295	Q
6"	900	10"	150	1786B-HP	1786D-HP	1786E-HP	14.180	91.489	8
6"	900	10"	150	1706RB-HP	1706RD-HP	1706RE-HP	16.000	103.232	R
6"	900	10"	150	1706RRB-HP	1706RRD-HP	1706RRE-HP	19.29	124.459	RR

Notes:

1. To determine the maximum allowable pressure at a given temperature, refer to the appropriate pressure/temperature tables from page 32.
2. Available in an ANSI Class 300 outlet flange.
3. For replacement valves only and on application, available in an ANSI Class 900 inlet flange.
4. For replacement valves and on application, available in an ANSI Class 1500 inlet flange.
5. Available with ANSI B16.5 inlet flange facings. See page 68 for selections.

Scope of Design (Contd.)

Flanged Inlet – Type 17_7, class 1500

Inlet ^{3&4} ANSI Std. R.F. Flange		Outlet ² ANSI Std. R.F. Flange		Type Numbers Maximum Temperature ¹			Orifice		Designation
Size	Class	Size	Class	750°F (399°C)	1020°F (549°C)	1060°F (571°C)	in ²	cm ²	
1-1/2"	1500	3"	150	1717B	1717D	1717E	.994	6.413	1
2"	1500	3"	150	1727B	1727D	1727E	1.431	9.232	2
2-1/2"	1500	6"	150	1737B	1737D	1737E	2.545	16.420	3
3"	1500	6"	150	1757B	1757D	1757E	3.341	21.556	5
3"	1500	6"	150	1747B	1747D	1747E	3.976	25.653	4
4"	1500	6"	150	1767B	1767D	1767E	7.070	45.616	6
6"	1500	8"	150	1777QB	1777QD	1777QE	11.050	71.295	Q
6"	1500	10"	150	1787B	1787D	1787E	14.180	91.489	8
6"	1500	10"	150	1707RB	1707RD	1707RE	16.000	103.232	R
6"	1500	10"	150	1707RRB	1707RRD	1707RRE	19.29	124.459	RR

Flanged Inlet – Type 17_9, class 2500

Inlet ⁴ ANSI Std. R.F. Flange		Outlet ANSI Std. R.F. Flange		Type Numbers Maximum Temperature ¹			Orifice		Designation
Size	Class	Size	Class	750°F (399°C)	1020°F (549°C)	1060°F (571°C)	in ²	cm ²	
1-1/2"	2500	4"	300	1719B	1719D	1719E	.994	6.413	1
2"	2500	4"	300	1729B	1729D	1729E	1.431	9.232	2
2-1/2"	2500	6"	300	1739B	1739D	1739E	2.545	16.420	3
3"	2500	6"	300	1759B	1759D	1759E	3.341	21.556	5
3"	2500	6"	300	1749B	1749D	1749E	3.976	25.653	4
4"	2500	8"	300	1769B	1769D	1769E	7.070	45.616	6

Notes:

1. To determine the maximum allowable pressure at a given temperature, refer to the appropriate pressure/temperature tables from page 32.
2. Available in an ANSI Class 300 outlet flange.
3. For replacement valves and on application, available in an ANSI Class 2500 inlet flange.
4. Available with ANSI B16.5 inlet flange facings. See page 68 for selections.

Scope of Design (Contd.)

Welded Inlet - Type 17_5W, class 600

Inlet Butt weld		Outlet ² ANSI Std. R.F. Flange		Type Numbers Maximum Temperature ¹			Orifice		Designation
Size	Class	Size	Class	750°F (399°C)	1020°F (549°C)	1060°F (571°C)	in ²	cm ²	
1-1/2"	600	3"	150	1715WB	1715WD	1715WE	.994	6.413	1
2"	600	3"	150	1725WB	1725WD	1725WE	1.431	9.232	2
2-1/2"	600	6"	150	1735WB	1735WD	1735WE	2.545	16.420	3
3"	600	6"	150	1755WB	1755WD	1755WE	3.341	21.556	4
3"	600	6"	150	1745WB	1745WD	1745WE	3.976	25.653	5
4"	600	6"	150	1765WB	1765WD	1765WE	7.070	45.616	6
4"	600	8"	150	1775QWB	1775QWD	1775QWE	12.25	79.037	Q
6"	600	8"	150	1775QWB	1775QWD	1775QWE	11.050	71.295	Q
6"	600	8"	150	1785WB	1785WD	1785WE	14.180	91.489	8
6"	600	8"	150	1705RWB	1705RWD	1705RWE	16.000	103.232	R
6"	600	8"	150	1705RRWB	1705RRWD	1705RRWE	19.29	124.459	RR

Welded Inlet - Type 17_6W, class 900

Inlet Butt weld		Outlet ² ANSI Std. R.F. Flange		Type Numbers Maximum Temperature ¹			Orifice		Designation
Size	Class	Size	Class	750°F (399°C)	1020°F (549°C)	1060°F (571°C)	in ²	cm ²	
1-1/2"	900	3"	150	1716WB	1716WD	1716WE	.994	6.413	1
2"	900	3"	150	1726WB	1726WD	1726WE	1.431	9.232	2
2-1/2"	900	6"	150	1736WB	1736WD	1736WE	2.545	16.420	3
3"	900	6"	150	1756WB	1756WD	1756WE	3.341	21.556	4
3"	900	6"	150	1746WB	1746WD	1746WE	3.976	25.653	5
4"	900	6"	150	1766WB	1766WD	1766WE	7.070	45.616	6
4"	900	8"	150	1776QWB	1776QWD	1776QWE	12.25	79.037	Q
6"	900	8"	150	1776QWB	1776QWD	1776QWE	11.050	71.295	Q
6"	900	10"	150	1786WB-HP	1786WD	1786WE	14.180	91.489	8
6"	900	10"	150	1706RWB-HP	1706RWD	1706RWE	16.000	103.232	R
6"	900	10"	150	1706RRWB-HP	1706RRWD	1706RRWE	19.29	124.459	RR

Notes:

1. To determine the maximum allowable pressure at a given temperature, refer to the appropriate pressure/temperature tables from page 32.
2. Available in an ANSI Class 300 outlet flange.

Scope of Design (Contd.)

Welded Inlet - Type 17_7W, class 1500

Inlet Butt weld		Outlet ² ANSI Std. R.F. Flange		Type Numbers Maximum Temperature ¹			Orifice		Designation
Size	Class	Size	Class	750°F (399°C)	1020°F (549°C)	1060°F (571°C)	in ²	cm ²	
1-1/2"	1500	3"	150	1717WB	1717WD	1717WE	.994	6.413	1
2"	1500	3"	150	1727WB	1727WD	1727WE	1.431	9.232	2
2-1/2"	1500	6"	150	1737WB	1737WD	1737WE	2.545	16.420	3
3"	1500	6"	150	1757WB	1757WD	1757WE	3.341	21.556	5
3"	1500	6"	150	1747WB	1747WD	1747WE	3.976	25.653	4
4"	1500	6"	150	1767WB	1767WD	1767WE	7.070	45.616	6
6"	1500	8"	150	1777QWB	1777QWD	1777QWE	11.050	71.295	Q
6"	1500	10"	150	1787WB	1787WD	1787WE	14.180	91.489	8
6"	1500	10"	150	1707RWB	1707RWD	1707RWE	16.000	103.232	R
6"	1500	10"	150	1707RRWB	1707RRWD	1707RRWE	19.29	124.459	RR

Welded Inlet - Type 17_9W, class 2500

Inlet Butt weld		Outlet ANSI Std. R.F. Flange		Type Numbers Maximum Temperature ¹			Orifice		Designation
Size	Class	Size	Class	750°F (399°C)	1020°F (549°C)	1060°F (571°C)	in ²	cm ²	
1-1/2"	2500	4"	300	1719B	1719D	1719E	.994	6.413	1
2"	2500	4"	300	1729B	1729D	1729E	1.431	9.232	2
2-1/2"	2500	6"	300	1739B	1739D	1739E	2.545	16.420	3
3"	2500	6"	300	1759B	1759D	1759E	3.341	21.556	5
3"	2500	6"	300	1749B	1749D	1749E	3.976	25.653	4

Notes:

1. To determine the maximum allowable pressure at a given temperature, refer to the appropriate pressure/temperature tables from page 32.
2. Available in an ANSI Class 300 outlet flange.

Scope of Design (Contd.)

Welded Inlet – Type 17_0W, class 3000

Inlet Butt weld		Outlet ANSI Std. R.F. Flange		Type Numbers Maximum Temperature ¹			Orifice		Designation
Size	Class	Size	Class	750°F (399°C)	1020°F (549°C)	1060°F (571°C)	in ²	cm ²	
1-1/2"	3000	4"	300	1710WB	1710WD	1710WE	.994	6.413	1
2"	3000	4"	300	1720WB	1720WD	1720WE	1.431	9.232	2
2-1/2"	3000	6"	300	1730WB	1730WD	1730WE	2.545	16.420	3
3"	3000	6"	300	1750WB	1750WD	1750WE	3.341	21.556	5
3"	3000	6"	300	1740WB	1740WD	1740WE	3.976	25.653	4
4"	3000	8"	300	1760WB	1760WD	1760WE	7.070	45.616	6

Welded Inlet – Type 17_3W, class 4500

Inlet Butt weld		Outlet ANSI Std. R.F. Flange		Type Numbers Maximum Temperature ¹			Orifice		Designation
Size	Class	Size	Class	750°F (399°C)	1020°F (549°C)	1060°F (571°C)	in ²	cm ²	
1-1/2"	4500	4"	300	1713WB	1713WD	1713WE	.994	6.413	1
2"	4500	6"	300	1723WB	1723WD	1723WE	1.431	9.232	2
2-1/2"	4500	6"	300	1733WB	1733WD	1733WE	2.545	16.420	3
3"	4500	8"	300	1753WB	1753WD	1753WE	3.341	21.556	5
3"	4500	8"	300	1743WB	1743WD	1743WE	3.976	25.653	4

Notes:

1. To determine the maximum allowable pressure at a given temperature, refer to the appropriate pressure/temperature tables from page 32.

Materials

17_5 Flanged

600 Pressure Class		
Ref. No.	Part	Material
Temp. Classes to 750°F (399°C)		
1	Base	SA217 WC6 Alloy Steel
2	• Disc Holder	Leaded Nickel Silver
3	• Guide	Leaded Nickel Silver
4	• Upper Adjusting Ring	Stainless Steel
5	Spring	Alloy Steel
Temp. Classes to 1020°F (549°C)		
1	Base	SA217 WC6 Alloy Steel
2	• Disc Holder	Monel
3	• Guide	Monel
4	• Upper Adjusting Ring	Stainless Steel
5	Spring	Alloy Steel
Temp. Classes to 1060°F (571°C)		
1	Base	SA217 WC6 Alloy Steel
2	• Disc Holder	Monel
3	• Guide	Monel
4	• Upper Adjusting Ring	Stainless Steel
5	Spring	Alloy Steel
All Temp. Classes		
6	Seat Bushing	Stainless Steel
7	• Disc	Inconel
8	• Lower Adjusting Ring	Stainless Steel
9	Disc Collar	Stainless Steel
10	Lift Stop	Stainless Steel
11	• Overlap Collar	Stainless Steel
12	Cover Plate Assembly	
12A	Cover Plate	WC6 Alloy Steel
12B	Floating Washer	Monel
12C	Washer Retainer	Stainless Steel
13	Top Plate Assembly	
13A	Top Plate	F11 Alloy Steel
13B	Washer Retainer	Stainless Steel
13C	Floating Washer	Monel
14	• Spindle	Stainless Steel
15	Compression Screw	Siicon Brass
16	Yoke	SA216 WCC Carbon Steel
17	Yoke Rod (Not Shown)	B16 Alloy Steel
18	Lifting Gear	Iron or Steel
19	• Upper Adjusting Ring Pin	Stainless Steel
20	• Lower Adjusting Ring Pin	Stainless Steel
21	Compression Screw Locknut	Siicon Brass
• = Recommended spare parts. See Maintenance Manual for quantity.		

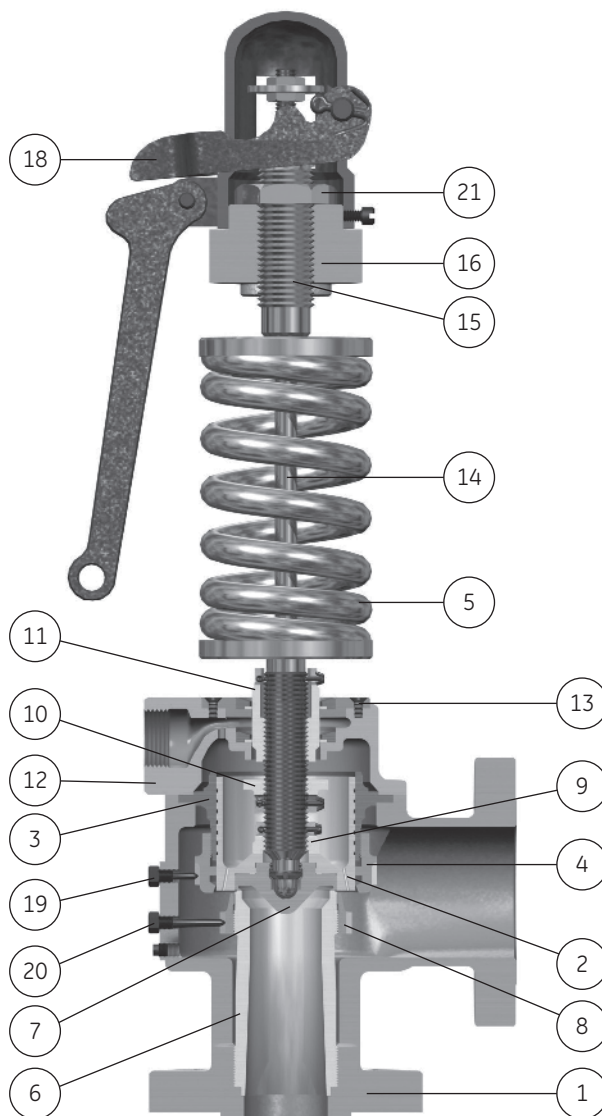

Note:

1. For F (1100°F/593°C) and G (1120°F/604°C) temperature class materials, contact factory.

Materials (Contd.)

17_6 Flanged

900 Pressure Class		
Ref. No.	Part	Material
Temp. Classes to 750°F (399°C)		
1	Base	SA217 WC6 Alloy Steel
2	• Disc Holder	Leaded Nickel Silver
3	• Guide	Leaded Nickel Silver
4	• Upper Adjusting Ring	Stainless Steel
5	Spring	Alloy Steel
Temp. Classes to 1020°F (549°C)		
1	Base	SA217 WC6 Alloy Steel
2	• Disc Holder	Monel
3	• Guide	Monel
4	• Upper Adjusting Ring	Stainless Steel
5	Spring	Alloy Steel
Temp. Classes to 1060°F (571°C)		
1	Base	SA217 WC9 Alloy Steel
2	• Disc Holder	Monel
3	• Guide	Monel
4	• Upper Adjusting Ring	Stainless Steel
5	Spring	Alloy Steel
All Temp. Classes		
6	Seat Bushing	Stainless Steel
7	• Disc	Inconel
8	• Lower Adjusting Ring	Stainless Steel
9	Disc Collar	Stainless Steel
10	Lift Stop	Stainless Steel
11	• Overlap Collar	Stainless Steel
12	Cover Plate Assembly	
12A	Cover Plate	WC6 Alloy Steel
12B	Floating Washer	Monel
12C	Washer Retainer	Stainless Steel
13	Top Plate Assembly	
13A	Top Plate	F11 Alloy Steel
13B	Washer Retainer	Stainless Steel
13C	Floating Washer	Monel
14	• Spindle	Stainless Steel
15	Compression Screw	Siicon Brass
16	Yoke	SA216 WCC Carbon Steel
17	Yoke Rod (Not Shown)	B16 Alloy Steel
18	Lifting Gear	Iron or Steel
19	• Upper Adjusting Ring Pin	Stainless Steel
20	• Lower Adjusting Ring Pin	Stainless Steel
21	Thrust Bearing	Siicon Brass
22	Compression Screw Adapter	Stainless Steel
23	Compression Screw Locknut	Siicon Brass
• = Recommended spare parts. See Maintenance Manual for quantity.		

Note:

- For F (1100°F/593°C) and G (1120°F/604°C) temperature class materials, contact factory.

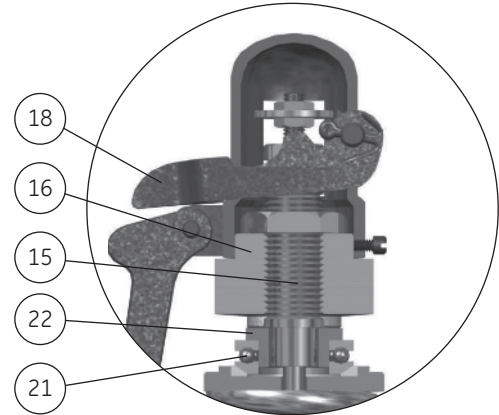

Valve Type Numbers
1786-HP & 1706RR-HP Only

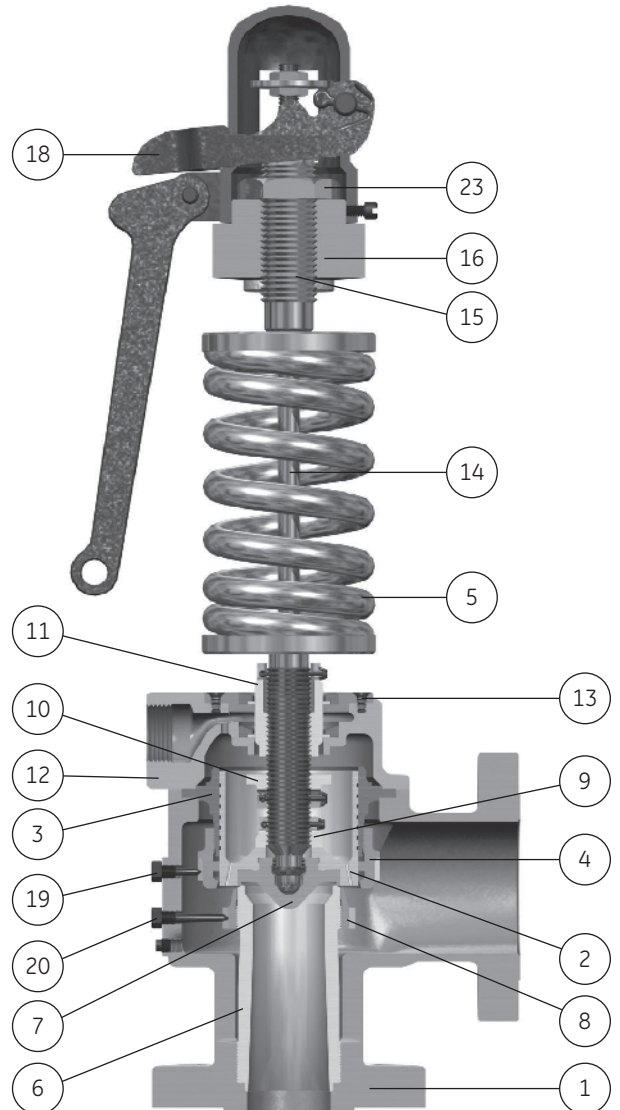

Materials (Contd.)

17_7 Flanged

1500 Pressure Class		
Ref. No.	Part	Material
Temp. Classes to 750°F (399°C)		
1	Base	SA217 WC6 Alloy Steel
2	• Disc Holder	Leaded Nickel Silver
3	• Guide	Leaded Nickel Silver
4	• Upper Adjusting Ring	Stainless Steel
5	Spring	Alloy Steel
Temp. Classes to 1020°F (549°C)		
1	Base	SA217 WC6 Alloy Steel
2	• Disc Holder	Monel
3	• Guide	Monel
4	• Upper Adjusting Ring	Stainless Steel
5	Spring	Alloy Steel
Temp. Classes to 1060°F (571°C)		
1	Base	SA217 WC9 Alloy Steel
2	• Disc Holder	Monel
3	• Guide	Monel
4	• Upper Adjusting Ring	Stainless Steel
5	Spring	Alloy Steel
All Temp. Classes		
6	Seat Bushing	Stainless Steel
7	• Disc	Inconel
8	• Lower Adjusting Ring	Stainless Steel
9	Disc Collar	Stainless Steel
10	Lift Stop	Stainless Steel
11	• Overlap Collar	Stainless Steel
12	Cover Plate Assembly	
12A	Cover Plate	WC6 Alloy Steel
12B	Floating Washer	Monel
12C	Washer Retainer	Stainless Steel
13	Top Plate Assembly	
13A	Top Plate	F11 Alloy Steel
13B	Washer Retainer	Stainless Steel
13C	Floating Washer	Monel
14	• Spindle	Stainless Steel
15	Compression Screw	Siicon Brass
16	Yoke	SA216 WCC Carbon Steel
17	Yoke Rod (Not Shown)	B16 Alloy Steel
18	Lifting Gear	Iron or Steel
19	• Upper Adjusting Ring Pin	Stainless Steel
20	• Lower Adjusting Ring Pin	Stainless Steel
21	Thrust Bearing	Steel
22	Compression Screw Adapter	Stainless Steel
23	Thrust Bearing Cover	Steel
24	Compression Screw Locknut	Siicon Brass
• = Recommended spare parts. See Maintenance Manual for quantity.		

Note:

- For F (1100°F/593°C) and G (1120°F/604°C) temperature class materials, contact factory.
- Locknut set screw supplied when valve set pressure is 2500 psig and above (Set screw not shown).

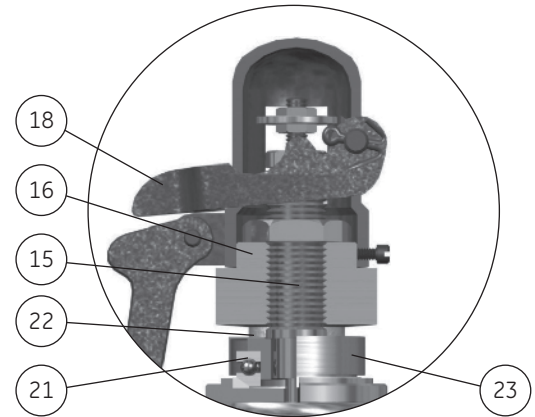

Valve Type Numbers
1787 & 1707R Only

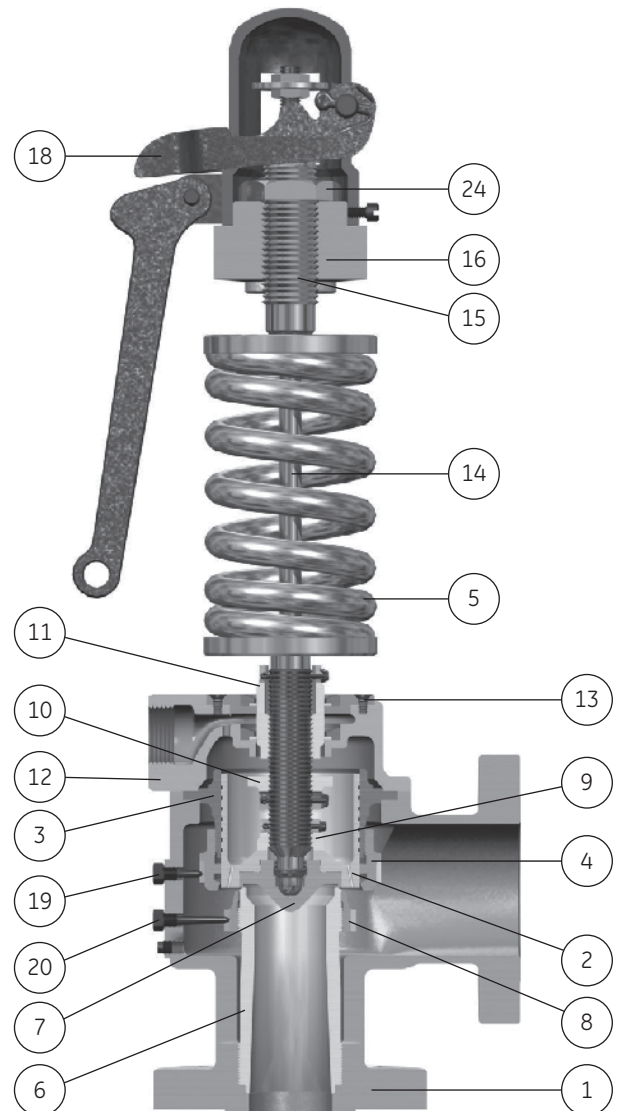

Materials (Contd.)

17_9 Flanged

2500 Pressure Class		
Ref. No.	Part	Material
Temp. Classes to 750°F (399°C)		
1	Base	SA217 WC6 Alloy Steel
2	• Disc Holder	Leaded Nickel Silver
3	• Guide	Leaded Nickel Silver
4	• Upper Adjusting Ring	Stainless Steel
5	Spring	Alloy Steel
Temp. Classes to 1020°F (549°C)		
1	Base	SA217 WC6 Alloy Steel
2	• Disc Holder	Monel
3	• Guide	Monel
4	• Upper Adjusting Ring	Stainless Steel
5	Spring	Alloy Steel
Temp. Classes to 1060°F (571°C)		
1	Base	SA217 WC9 Alloy Steel
2	• Disc Holder	Monel
3	• Guide	Monel
4	• Upper Adjusting Ring	Stainless Steel
5	Spring	Alloy Steel
All Temp. Classes		
6	Seat Bushing	Stainless Steel
7	• Disc	Inconel
8	• Lower Adjusting Ring	Stainless Steel
9	Disc Collar	Stainless Steel
10	Lift Stop	Stainless Steel
11	• Overlap Collar	Stainless Steel
12	Cover Plate Assembly	
12A	Cover Plate	WC6 Alloy Steel
12B	Floating Washer	Monel
12C	Washer Retainer	Stainless Steel
13	Top Plate Assembly	
13A	Top Plate	F11 Alloy Steel
13B	Washer Retainer	Stainless Steel
13C	Floating Washer	Monel
14	• Spindle	Stainless Steel
15	Compression Screw	Siicon Brass
16	Yoke	SA216 WCC Carbon Steel
17	Yoke Rod (Not Shown)	B16 Alloy Steel
18	Lifting Gear	Iron or Steel
19	• Upper Adjusting Ring Pin	Stainless Steel
20	• Lower Adjusting Ring Pin	Stainless Steel
21	Thrust Bearing	Steel
22	Compression Screw Adapter	Stainless Steel
23	Spindle Button (1719 Only)	Stainless Steel
24	Compression Screw Locknut	Siicon Brass
• = Recommended spare parts. See Maintenance Manual for quantity.		

Note:

- For F (1100°F/593°C) and G (1120°F/604°C) temperature class materials, contact factory.
- Locknut set screw supplied when valve set pressure is 2500 psig and above (Set screw not shown).

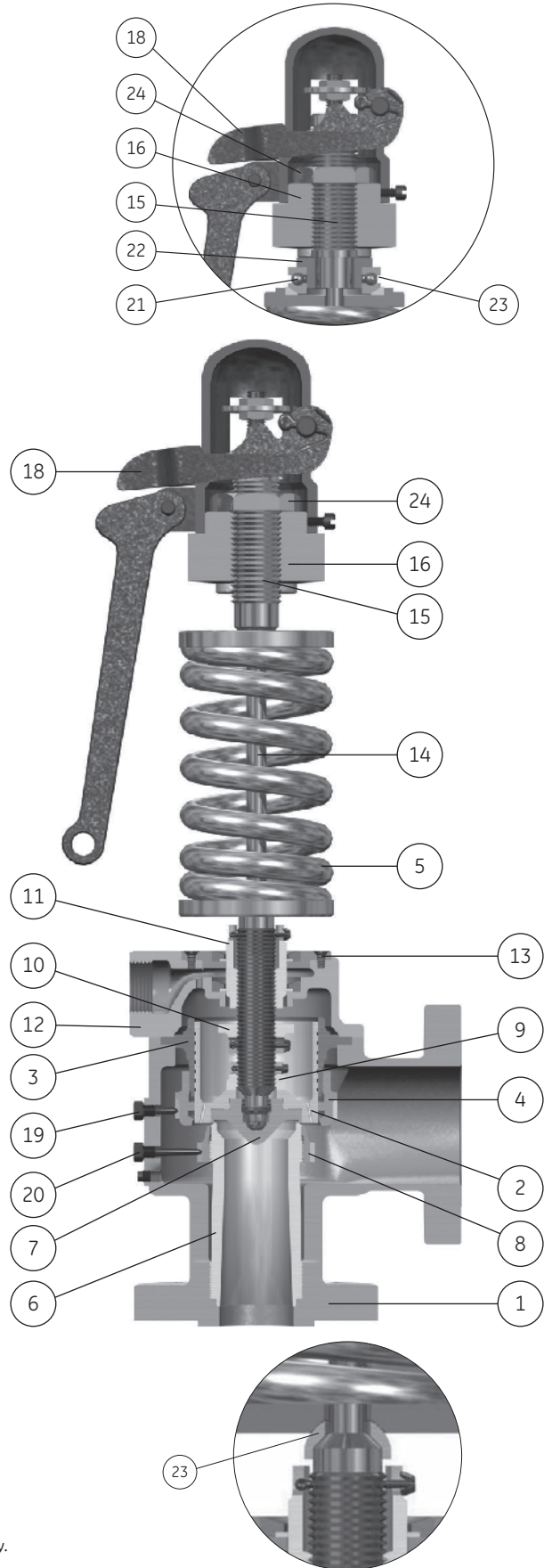

Materials (Contd.)

17_5W Welded Inlet

600 Pressure Class		
Ref. No.	Part	Material
Temp. Classes to 750°F (399°C)		
1	Base	SA216 WCC
1A	Inlet Neck (1.5" through 3")	SA105 Carbon Steel
2	• Disc Holder	Leaded Nickel Silver
3	• Guide	Leaded Nickel Silver
4	• Upper Adjusting Ring	Stainless Steel
5	Spring	Alloy Steel
Temp. Classes to 1020°F (549°C)		
1	Base	SA217 WC6 Alloy Steel
1A	Inlet Neck	SA182 F11 Alloy Steel
2	• Disc Holder	Monel
3	• Guide	Monel
4	• Upper Adjusting Ring	Stainless Steel
5	Spring	Alloy Steel
Temp. Classes to 1060°F (571°C)		
1	Base	SA217 WC9 Alloy Steel
1A	Inlet Neck	SA182 F22 Alloy Steel
2	• Disc Holder	Monel
3	• Guide	Monel
4	• Upper Adjusting Ring	Stainless Steel
5	Spring	Alloy Steel
All Temp. Classes		
6	Seat Bushing	Stainless Steel
7	• Disc	Inconel
8	• Lower Adjusting Ring	Stainless Steel
9	Disc Collar	Stainless Steel
10	Lift Stop	Stainless Steel
11	• Overlap Collar	Stainless Steel
12	Cover Plate Assembly	
12A	Cover Plate	WC6 Alloy Steel
12B	Floating Washer	Monel
12C	Washer Retainer	Stainless Steel
13	Top Plate Assembly	
13A	Top Plate	F11 Alloy Steel
13B	Washer Retainer	Stainless Steel
13C	Floating Washer	Monel
14	• Spindle	Stainless Steel
15	Compression Screw	Siicon Brass
16	Yoke	SA216 WCC Carbon Steel
17	Yoke Rod (Not Shown)	B16 Alloy Steel
18	Lifting Gear	Iron or Steel
19	• Upper Adjusting Ring Pin	Stainless Steel
20	• Lower Adjusting Ring Pin	Stainless Steel
21	Compression Screw	Siicon Brass
• = Recommended spare parts. See Maintenance Manual for quantity.		

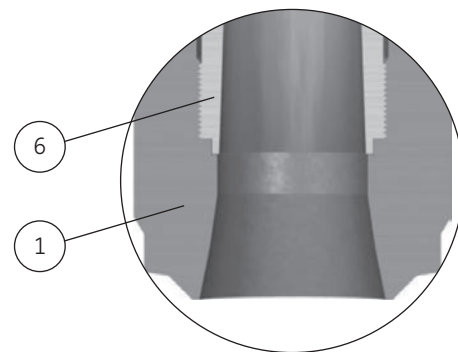
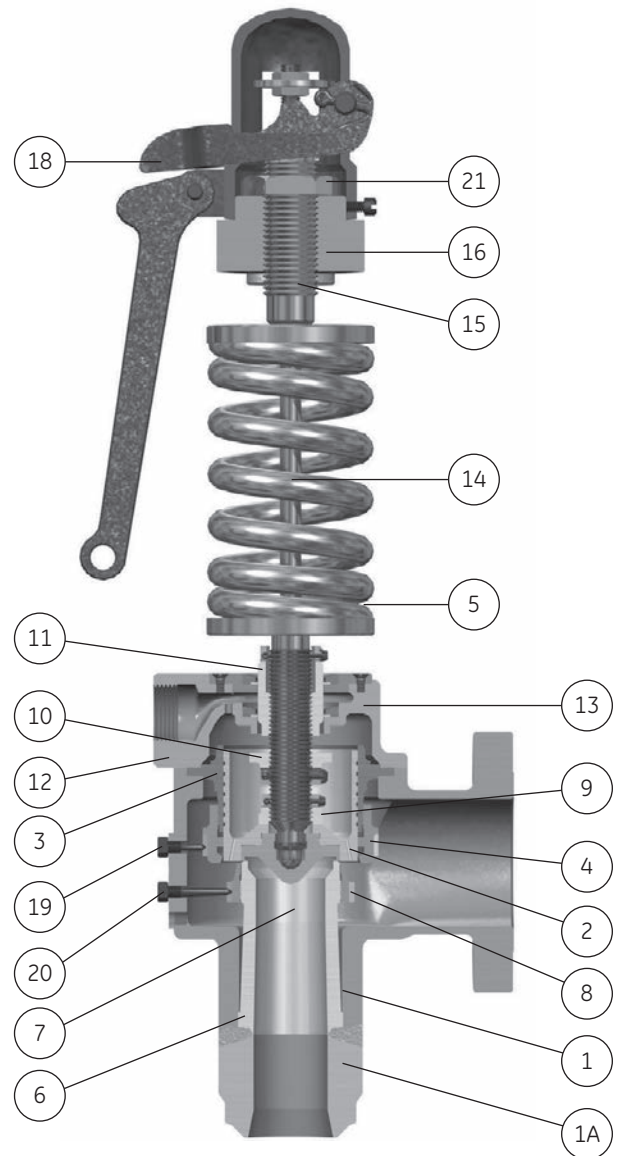

4" Through 6"
Cast Inlet Neck

Note:

1. For F (1100°F/593°C) and G (1120°F/604°C) temperature class materials, contact factory.

Materials (Contd.)

17_6W Welded Inlet

900 Pressure Class		
Ref. No.	Part	Material
Temp. Classes to 750°F (399°C)		
1	Base	SA216 WCC
1A	Inlet Neck (1.5" through 3")	SA105 Carbon Steel
2	• Disc Holder	Leaded Nickel Silver
3	• Guide	Leaded Nickel Silver
4	• Upper Adjusting Ring	Stainless Steel
5	Spring	Alloy Steel
Temp. Classes to 1020°F (549°C)		
1	Base	SA217 WC6 Alloy Steel
1A	Inlet Neck	SA182 F11 Alloy Steel
2	• Disc Holder	Monel
3	• Guide	Monel
4	• Upper Adjusting Ring	Stainless Steel
5	Spring	Alloy Steel
Temp. Classes to 1060°F (571°C)		
1	Base	SA217 WC9 Alloy Steel
1A	Inlet Neck	SA182 F22 Alloy Steel
2	• Disc Holder	Monel
3	• Guide	Monel
4	• Upper Adjusting Ring	Stainless Steel
5	Spring	Alloy Steel
All Temp. Classes		
6	Seat Bushing	Stainless Steel
7	• Disc	Inconel
8	• Lower Adjusting Ring	Stainless Steel
9	Disc Collar	Stainless Steel
10	Lift Stop	Stainless Steel
11	• Overlap Collar	Stainless Steel
12	Cover Plate Assembly	
12A	Cover Plate	WC6 Alloy Steel
12B	Floating Washer	Monel
12C	Washer Retainer	Stainless Steel
13	Top Plate Assembly	
13A	Top Plate	F11 Alloy Steel
13B	Washer Retainer	Stainless Steel
13C	Floating Washer	Monel
14	• Spindle	Stainless Steel
15	Compression Screw	Siicon Brass
16	Yoke	SA216 WCC Carbon Steel
17	Yoke Rod (Not Shown)	B16 Alloy Steel
18	Lifting Gear	Iron or Steel
19	• Upper Adjusting Ring Pin	Stainless Steel
20	• Lower Adjusting Ring Pin	Stainless Steel
21	Compression Screw	Siicon Brass
22	Thrust Bearing	Steel
23	Compression Screw Adapter	Stainless Steel

• = Recommended spare parts. See Maintenance Manual for quantity.

Note:

1. For F (1100°F/593°C) and G (1120°F/604°C) temperature class materials, contact factory.

© 2018 Baker Hughes, a GE company. All rights reserved.

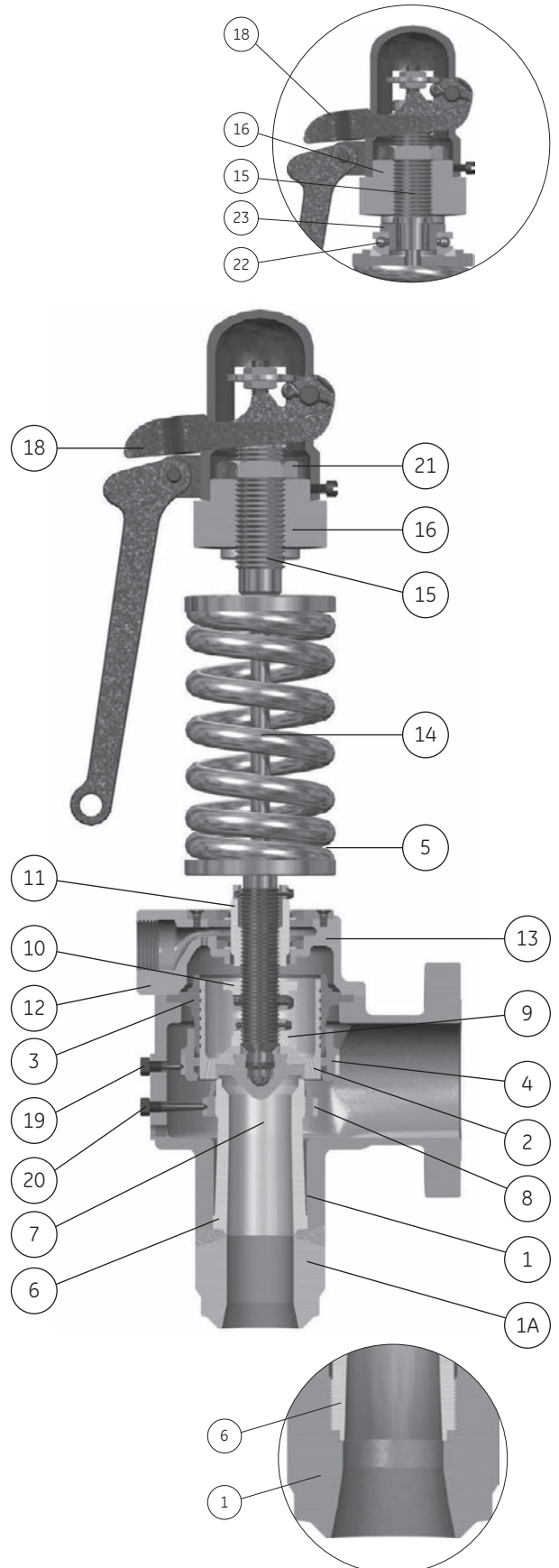

4" Through 6"
Cast Inlet Neck

Materials (Contd.)

17_7W Welded Inlet

1500 Pressure Class		
Ref. No.	Part	Material
Temp. Classes to 750°F (399°C)		
1	Base	SA216 WCC
1A	Inlet Neck (1.5" through 3")	SA105 Carbon Steel
2	• Disc Holder	Leaded Nickel Silver
3	• Guide	Leaded Nickel Silver
4	• Upper Adjusting Ring	Stainless Steel
5	Spring	Alloy Steel
Temp. Classes to 1020°F (549°C)		
1	Base	SA217 WC6 Alloy Steel
1A	Inlet Neck	SA182 F11 Alloy Steel
2	• Disc Holder	Monel
3	• Guide	Monel
4	• Upper Adjusting Ring	Stainless Steel
5	Spring	Alloy Steel
Temp. Classes to 1060°F (571°C)		
1	Base	SA217 WC9 Alloy Steel
1A	Inlet Neck	SA182 F22 Alloy Steel
2	• Disc Holder	Monel
3	• Guide	Monel
4	• Upper Adjusting Ring	Stainless Steel
5	Spring	Alloy Steel
All Temp. Classes		
6	Seat Bushing	Stainless Steel
7	• Disc	Inconel
8	• Lower Adjusting Ring	Stainless Steel
9	Disc Collar	Stainless Steel
10	Lift Stop	Stainless Steel
11	• Overlap Collar	Stainless Steel
12	Cover Plate Assembly	
12A	Cover Plate	WC6 Alloy Steel
12B	Floating Washer	Monel
12C	Washer Retainer	Stainless Steel
13	Top Plate Assembly	
13A	Top Plate	F11 Alloy Steel
13B	Washer Retainer	Stainless Steel
13C	Floating Washer	Monel
14	• Spindle	Stainless Steel
15	Compression Screw	Siicon Brass
16	Yoke	SA216 WCC Carbon Steel
17	Yoke Rod (Not Shown)	B16 Alloy Steel
18	Lifting Gear	Iron or Steel
19	• Upper Adjusting Ring Pin	Stainless Steel
20	• Lower Adjusting Ring Pin	Stainless Steel
21	Thrust Bearing	Steel
22	Compression Screw Adapter	Stainless Steel
23	Spindle Button (1719 Only)	Stainless Steel
24	Compression Screw	Siicon Brass
• = Recommended spare parts. See Maintenance Manual for quantity.		

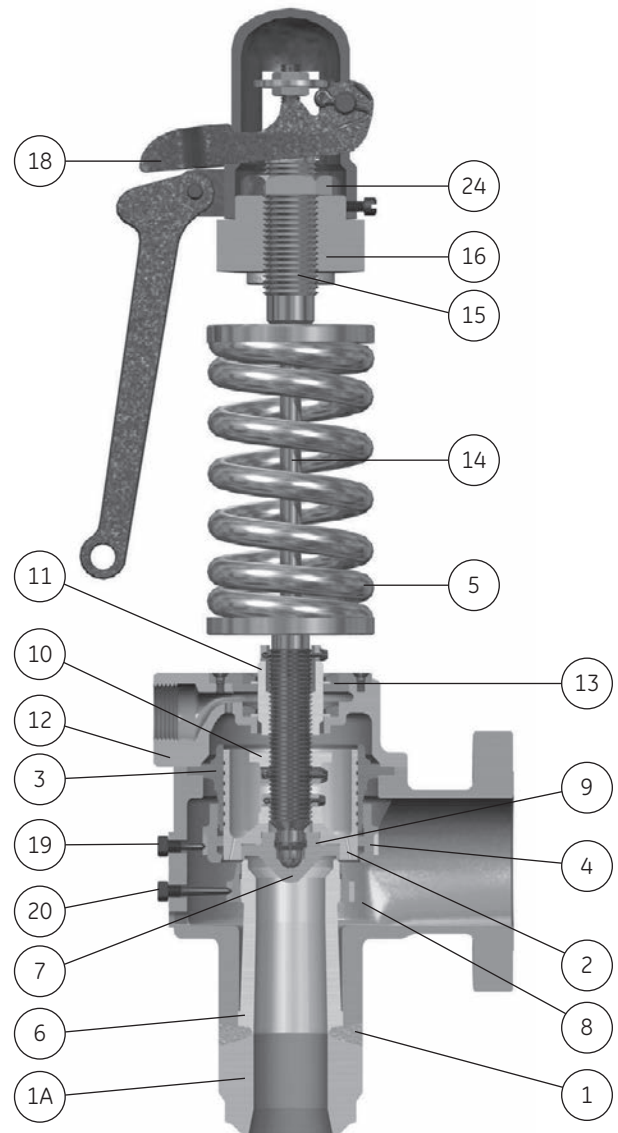
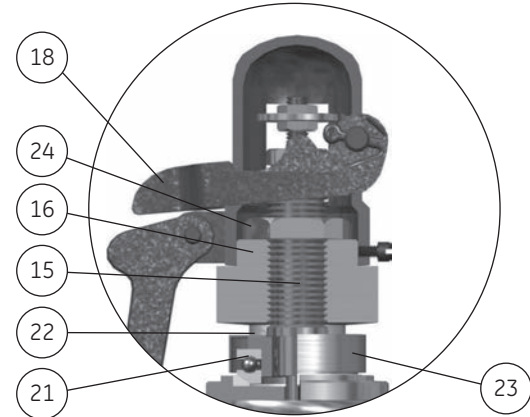

Note:

- For F (1100°F/593°C) and G (1120°F/604°C) temperature class materials, contact factory.
- Locknut set screw supplied when valve set pressure is 2500 psig and above.

Materials (Contd.)

17_9W Welded Inlet

2500 Pressure Class		
Ref. No.	Part	Material
Temp. Classes to 750°F (399°C)		
1	Base	SA216 WCC
1A	Inlet Neck (1.5" through 3")	SA105 Carbon Steel
2	• Disc Holder	Leaded Nickel Silver
3	• Guide	Leaded Nickel Silver
4	• Upper Adjusting Ring	Stainless Steel
5	Spring	Alloy Steel
Temp. Classes to 1020°F (549°C)		
1	Base	SA217 WC6 Alloy Steel
1A	Inlet Neck	SA182 F11 Alloy Steel
2	• Disc Holder	Monel
3	• Guide	Monel
4	• Upper Adjusting Ring	Stainless Steel
5	Spring	Alloy Steel
Temp. Classes to 1060°F (571°C)		
1	Base	SA217 WC9 Alloy Steel
1A	Inlet Neck	SA182 F22 Alloy Steel
2	• Disc Holder	Monel
3	• Guide	Monel
4	• Upper Adjusting Ring	Stainless Steel
5	Spring	Alloy Steel
All Temp. Classes		
6	Seat Bushing	Stainless Steel
7	• Disc	Inconel
8	• Lower Adjusting Ring	Stainless Steel
9	Disc Collar	Stainless Steel
10	Lift Stop	Stainless Steel
11	• Overlap Collar	Stainless Steel
12	Cover Plate Assembly	
12A	Cover Plate	WC6 Alloy Steel
12B	Floating Washer	Monel
12C	Washer Retainer	Stainless Steel
13	Top Plate Assembly	
13A	Top Plate	F11 Alloy Steel
13B	Washer Retainer	Stainless Steel
13C	Floating Washer	Monel
14	• Spindle	Stainless Steel
15	Compression Screw	Siicon Brass
16	Yoke	SA216 WCC Carbon Steel
17	Yoke Rod (Not Shown)	B16 Alloy Steel
18	Lifting Gear	Iron or Steel
19	• Upper Adjusting Ring Pin	Stainless Steel
20	• Lower Adjusting Ring Pin	Stainless Steel
21	Thrust Bearing	Steel
22	Compression Screw Adapter	Stainless Steel
23	Spindle Button	Stainless Steel
24	Compression Screw Locknut	Siicon Brass
25	Locknut Set Screw (Not Shown)	Stainless Steel
• = Recommended spare parts. See Maintenance Manual for quantity.		

Note:

- For F (1100°F/593°C) and G (1120°F/604°C) temperature class materials, contact factory.
- Locknut set screw supplied when valve set pressure is 2500 psig and above.

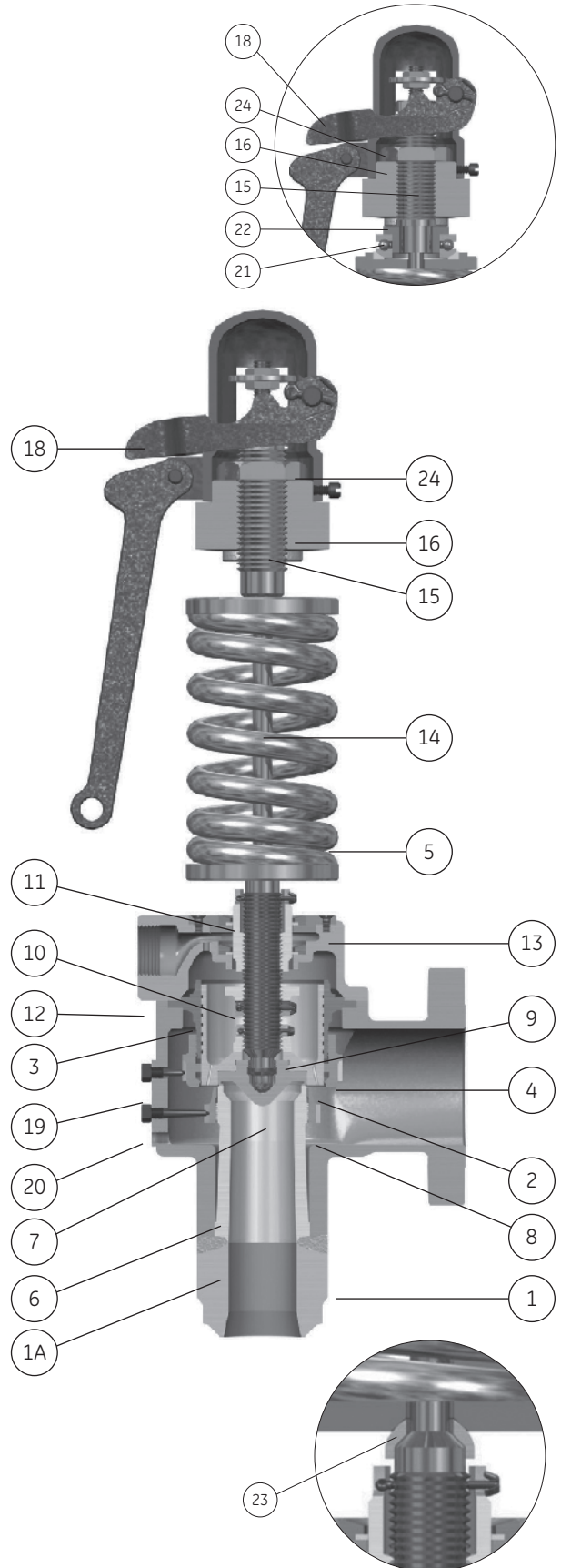

Valve Type Number
1719 Only

Materials (Contd.)

17_0W Welded Inlet

3000 Pressure Class		
Ref. No.	Part	Material
Temp. Classes to 750°F (399°C)		
1	Base	SA216 WCC
1A	Inlet Neck (1.5" through 3")	SA105 Carbon Steel
2	• Disc Holder	Leaded Nickel Silver
3	• Guide	Leaded Nickel Silver
4	• Upper Adjusting Ring	Stainless Steel
5	Spring	Alloy Steel
Temp. Classes to 1020°F (549°C)		
1	Base	SA217 WC6 Alloy Steel
1A	Inlet Neck	SA182 F11 Alloy Steel
2	• Disc Holder	Monel
3	• Guide	Monel
4	• Upper Adjusting Ring	Stainless Steel
5	Spring	Alloy Steel
Temp. Classes to 1060°F (571°C)		
1	Base	SA217 WC9 Alloy Steel
1A	Inlet Neck	SA182 F22 Alloy Steel
2	• Disc Holder	Monel
3	• Guide	Monel
4	• Upper Adjusting Ring	Stainless Steel
5	Spring	Alloy Steel
All Temp. Classes		
6	Seat Bushing	Stainless Steel
7	• Disc	Inconel
8	• Lower Adjusting Ring	Stainless Steel
9	Disc Collar	Stainless Steel
10	Lift Stop	Stainless Steel
11	• Overlap Collar	Stainless Steel
12	Cover Plate Assembly	
12A	Cover Plate	WC6 Alloy Steel
12B	Floating Washer	Monel
12C	Washer Retainer	Stainless Steel
13	Top Plate Assembly	
13A	Top Plate	F11 Alloy Steel
13B	Washer Retainer	Stainless Steel
13C	Floating Washer	Monel
14	• Spindle	Stainless Steel
15	Compression Screw	Siicon Brass
16	Yoke	SA216 WCC Carbon Steel
17	Yoke Rod (Not Shown)	B16 Alloy Steel
18	Lifting Gear	Iron or Steel
19	• Upper Adjusting Ring Pin	Stainless Steel
20	• Lower Adjusting Ring Pin	Stainless Steel
21	Thrust Bearing	Steel
22	Compression Screw Adapter	Stainless Steel
23	Spindle Button	Stainless Steel
24	Compression Screw Locknut	Siicon Brass
25	Locknut Set Screw (Not Shown)	Stainless Steel
• = Recommended spare parts. See Maintenance Manual for quantity.		

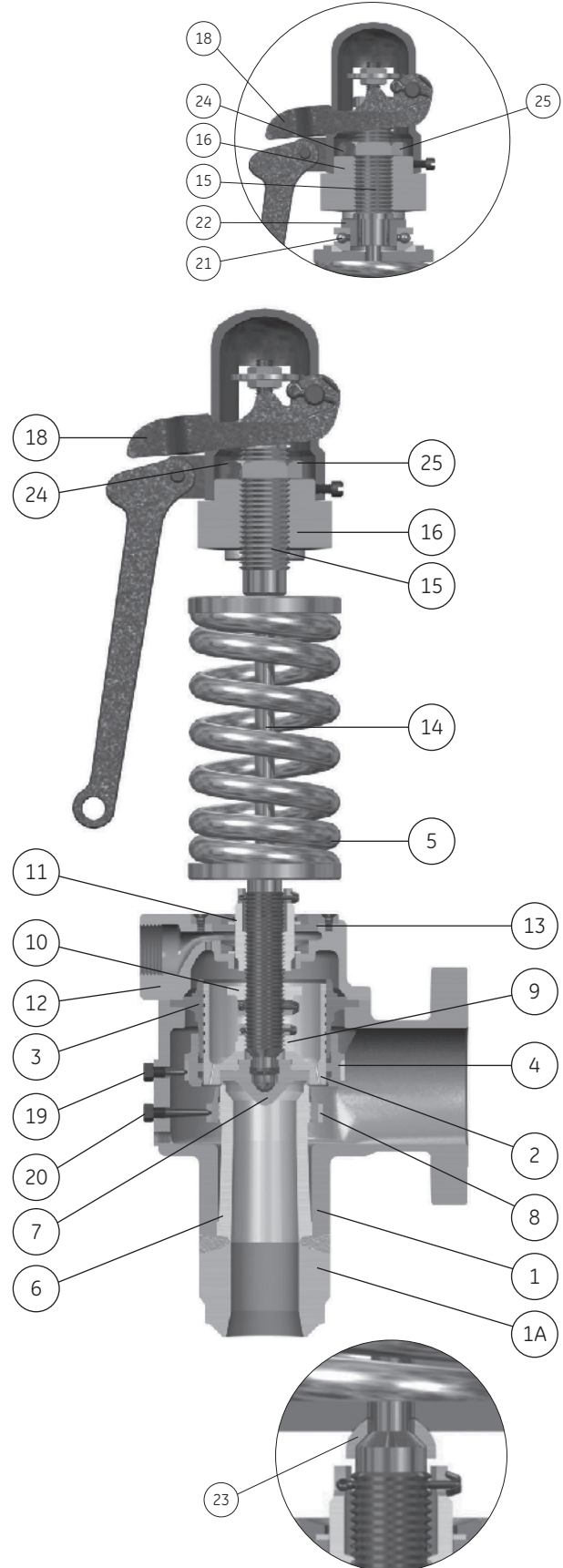

Valve Type Numbers
1790 & 1760 Only

Note:
1. For F (1100°F/593°C) and G (1120°F/604°C) temperature class materials, contact factory.
16 | BHGE

Materials (Contd.)

17_3W Welded Inlet

4500 Pressure Class		
Ref. No.	Part	Material
Temp. Classes to 750°F (399°C)		
1	Base	SA216 WCC
1A	Inlet Neck (1.5" through 3")	SA105 Carbon Steel
2	• Disc Holder	Leaded Nickel Silver
3	• Guide	Leaded Nickel Silver
4	• Upper Adjusting Ring	Stainless Steel
5	Spring	Alloy Steel
Temp. Classes to 1020°F (549°C)		
1	Base	SA217 WC6 Alloy Steel
1A	Inlet Neck	SA182 F11 Alloy Steel
2	• Disc Holder	Monel
3	• Guide	Monel
4	• Upper Adjusting Ring	Stainless Steel
5	Spring	Alloy Steel
Temp. Classes to 1060°F (571°C)		
1	Base	SA217 WC9 Alloy Steel
1A	Inlet Neck	SA182 F22 Alloy Steel
2	• Disc Holder	Monel
3	• Guide	Monel
4	• Upper Adjusting Ring	Stainless Steel
5	Spring	Alloy Steel
All Temp. Classes		
6	Seat Bushing	Stainless Steel
7	• Disc	Inconel
8	• Lower Adjusting Ring	Stainless Steel
9	Disc Collar	Stainless Steel
10	Lift Stop	Stainless Steel
11	• Overlap Collar	Stainless Steel
12	Cover Plate Assembly	
12A	Cover Plate	WC6 Alloy Steel
12B	Floating Washer	Monel
12C	Washer Retainer	Stainless Steel
13	Top Plate Assembly	
13A	Top Plate	F11 Alloy Steel
13B	Washer Retainer	Stainless Steel
13C	Floating Washer	Monel
14	• Spindle	Stainless Steel
15	Compression Screw	Siicon Brass
16	Yoke	SA216 WCC Carbon Steel
17	Yoke Rod (Not Shown)	B16 Alloy Steel
18	Lifting Gear	Iron or Steel
19	• Upper Adjusting Ring Pin	Stainless Steel
20	• Lower Adjusting Ring Pin	Stainless Steel
21	Thrust Bearing	Steel
22	Compression Screw Adapter	Stainless Steel
23	Thrust Bearing Cover	Steel
24	Locknut Set Screw (Not Shown)	Steel
25	Copression Screw Locknut	Siicon Brass
• = Recommended spare parts. See Maintenance Manual for quantity.		

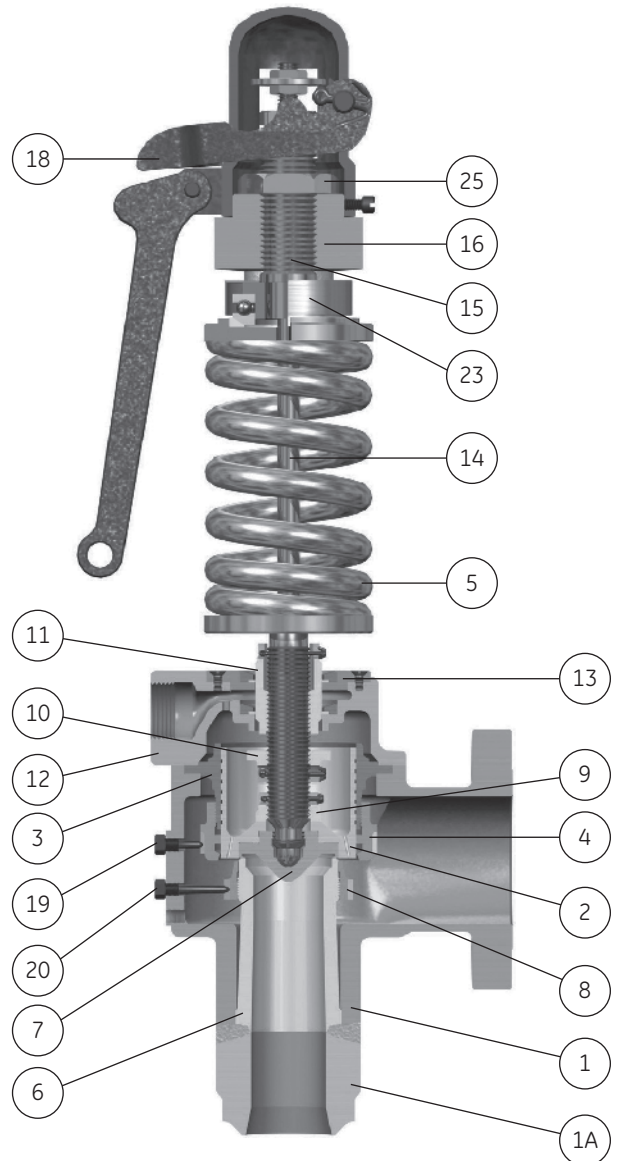

Materials (Contd.)

Alternate Materials for Base Assembly

Consolidated safety valves are supplied to meet the specific material requirements of our customers. The following special material requirements are available for the safety valves listed. Many boiler manufactures now prefer to match the safety valve inlet neck material to the material being used on the header and nozzle inlet. By matching the materials, welding procedures can be simplified and the overall cost of installation reduced.

Some customers prefer that the valve be supplied with the same material for both the inlet neck and seat bushing. This material

combination is often requested when rapid startup is expected on the boiler, as is the case with peaking units. When heat is applied, the expansion rate is constant for both the inlet neck and seat bushing. Both the inlet neck and seat bushing are manufactured from high strength forged material integrally welded to the cast valve body. A Stellite deposit is added to the seating area.

Valve Construction	
Pressure Class	Valve Type
600	1715W
	1725W
	1735W
	1755W
	1745W
900	1716W
	1726W
	1736W
	1756W
	1746W
1500	1717W
	1727W
	1737W
	1757W
	1747W
	1767W
	1777QW
	1787W
	1707RW
	1707RRW
2500	1719W
	1729W
	1739W
	1759W
	1749W
3000	1710W
	1720W
	1730W
	1750W
	1740W
4500	1760W
	1713W
	1723W
	1733W
	1753W
1743W	

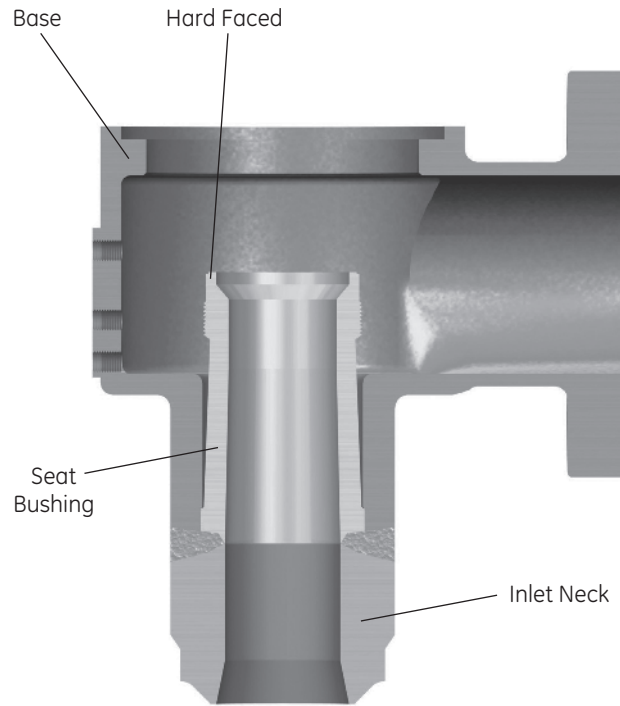

Ref. No.	Material Options					
	Part	Material				
1	Base	ASME SA216 WCC	ASME SA217 WC 6	ASME SA217 WC 9	ASME SA217 WC 9	ASME SA217 C12A
2	Inlet Neck ¹	ASME SA105	ASME SA182 F11	ASME SA182 F22	ASME SA182 F91	ASME SA182 F91
3	Seat Bushing ^{1&2}	ASME SA105	ASME SA182 F11	ASME SA182 F22	ASME SA182 F91	ASME SA182 F91
4	Hard Faced	Stellite	Stellite	Stellite	Stellite	Stellite

Note:

1. Inlet neck and seat bushing can be supplied of one-piece construction on application.
2. Also available in ASME SA479 GR. 410 Material.

Dimensions and Weights (USCS)

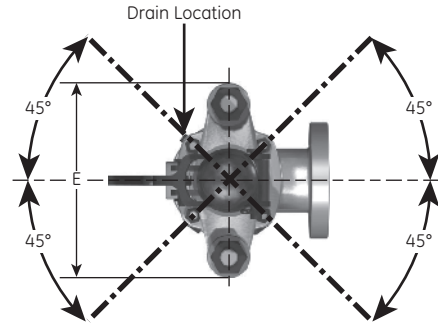
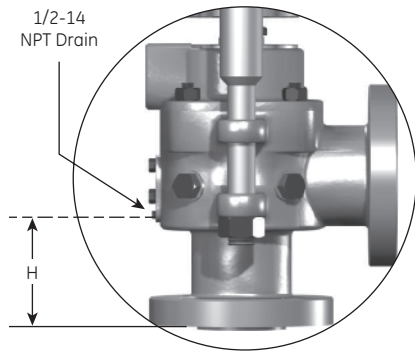

Cap and lever may be rotated 45° horizontally to either side of centerline
 Drain location for 4" & 6" valves is on centerline of outlet

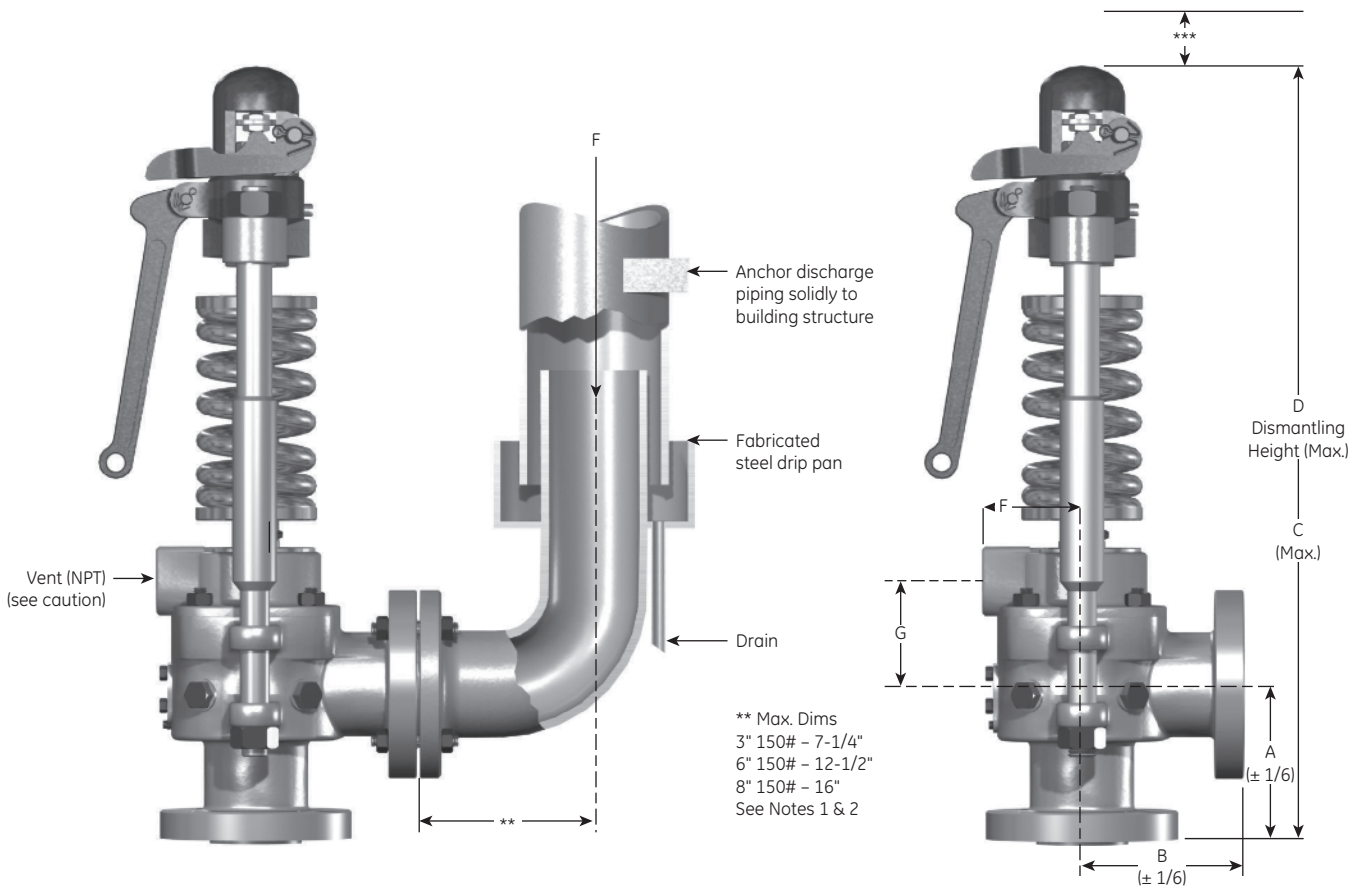

** Max. Dims
 3" 150# - 7-1/4"
 6" 150# - 12-1/2"
 8" 150# - 16"
 See Notes 1 & 2

***The EVT-I and Hydroset require 15" clearance.

The EVT-II requires 17" clearance. And an additional 8" is required when the assisted closing device is utilized.

CAUTION

Steam flow will occur through the coverplate vent when the valve is in the open position. Do not plug. Pipe to safe location.

Notes:

1. For lever clearance dimensions see page 31.
2. Appropriate considerations should be made for draining any condensate which may accumulate in the cover plate vent piping, body bowl drain, and drip pan elbow arrangement.

Dimensions & Weights (USCS) (Contd.)

Flanged Inlet - Type 17_5, class 600

Size and Type	All Temperature Classes								Vent NPT	Approx. Weight lbs.
	A in.	B in.	C in.	D in.	E in.	F in.	G in.	H in.		
1-1/2" - 1715	6	5-1/4	23-3/4	28	9	3-1/4	3-9/16	4-15/16	1	85
2" - 1725	7	5-1/2	28-1/2	34-1/2	10-1/4	3-3/8	4-5/8	5-15/16	1-1/4	100
2-1/2" - 1735	8-1/4	7	33-1/2	40-3/4	13	3-7/16	4-13/16	6-3/16	1-1/4	240
3" - 1755	8-1/2	7	37-1/4	44-3/4	15-1/2	3-15/16	5-1/2	5-15/16	1-1/2	285
3" - 1745	8-1/2	7	37-1/4	44-3/4	15-1/2	3-15/16	5-1/2	5-15/16	1-1/2	285
4" - 1765	9	8	40-3/4	49-1/4	15-1/2	5-13/16	6-7/8	6-7/16	2	475
4" - 1775Q	8-3/4	9	45-1/4	55-1/4	19	6	8-3/16	5-5/16	2	550
6" - 1775Q	12-11/16	9	49-1/4	59-1/4	19	6	8-3/16	9-1/4	2	600
6" - 1785	10-11/16	10	50-1/2	62-3/4	20-1/4	7-1/4	8-7/16	7-1/4	2-1/2	750
6" - 1705R	10-11/16	10	55-1/4	71-1/4	20-1/4	7-1/4	8-7/16	7-9/32	2-1/2	765
6" - 1705RR	10-11/16	10	55-1/4	71-1/4	20-1/4	7-1/4	8-7/16	7-9/32	2-1/2	765

Flanged Inlet - Type 17_6, class 900

Size and Type	All Temperature Classes								Vent NPT	Approx. Weight lbs.
	A in.	B in.	C in.	D in.	E in.	F in.	G in.	H in.		
1-1/2" - 1716	6	5-1/4	23-3/4	28	9	3-1/4	3-9/16	4-15/16	1	90
2" - 1726	7	5-1/2	29-3/4	35-1/2	10-1/4	3-3/8	4-5/8	5-15/16	1-1/4	110
2-1/2" - 1736	8-1/4	7	34-1/4	42	13	3-7/16	4-13/16	6-3/16	1-1/4	250
3" - 1756	8-5/8	7	38-1/2	46-3/4	15-1/2	3-15/16	5-1/2	6-1/16	1-1/2	385
3" - 1746	8-5/8	7	38-1/2	46-3/4	15-1/2	3-15/16	5-1/2	6-1/16	1-1/2	385
4" - 1766	9-1/8	8	42-3/4	53-1/4	15-1/2	5-13/16	6-7/8	6-9/16	2	500
4" - 1776Q	9	9	47-1/2	59-1/2	19	6	8-3/16	5-9/16	2	575
6" - 1776Q	13	9	51-1/2	63-1/2	19	6	8-3/16	9-5/16	2	640
6" - 1786-HP	15-7/16	10-1/2	64-7/16	71-7/16	21-1/2	7-1/16	8-9/16	11	2-1/2	1200
6" - 1706R-HP	15-7/16	10-1/2	64-7/16	71-7/16	21-1/2	7-1/16	8-9/16	11	2-1/2	1200
6" - 1706RR-HP	15-7/16	10-1/2	64-7/16	71-7/16	21-1/2	7-1/16	8-9/16	11	2-1/2	1200

Flanged Inlet - Type 17_7, class 1500

Size and Type	All Temperature Classes								Vent NPT	Approx. Weight lbs.
	A in.	B in.	C in.	D in.	E in.	F in.	G in.	H in.		
1-1/2" - 1717	6	5-1/4	25-1/2	31-1/2	9	3-1/4	3-9/16	4-15/16	1	90
2" - 1727	7	5-1/2	31-1/4	38-1/2	10-1/4	3-3/8	4-5/8	5-15/16	1-1/4	140
2-1/2" - 1737	8-1/4	7	34-1/4	42	13	3-7/16	4-13/16	6-3/16	1-1/4	250
3" - 1757	9	7	40-1/2	51	15-1/2	3-15/16	5-1/2	7-7/16	1-1/2	400
3" - 1747	9	7	40-1/2	51	15-1/2	3-15/16	5-1/2	6-7/16	1-1/2	400
4" - 1767	9-1/2	8	45	57-1/2	15-1/2	5-13/16	6-7/8	6-15/16	2	600
6" - 1777Q	14-1/4	10	57-1/2	73-1/2	19-3/4	7-1/4	8-7/16	10-13/16	2-1/2	850
6" - 1787	16-1/2	10-1/2	68-3/8	77-7/8	21-1/2	7-1/16	8-9/16	12-1/16	2-1/2	1280
6" - 1707R	16-1/2	10-1/2	68-3/8	77-7/8	21-1/2	7-1/16	8-9/16	12-1/16	2-1/2	1312
6" - 1707RR	16-1/2	10-1/2	68-3/8	77-7/8	21-1/2	7-1/16	8-9/16	12-1/16	2-1/2	1312

Flanged Inlet - Type 17_9, class 2500

Size and Type	All Temperature Classes								Vent NPT	Approx. Weight lbs.
	A in.	B in.	C in.	D in.	E in.	F in.	G in.	H in.		
1-1/2" - 1719	8-3/4	6-1/2	30-1/4	36	10-3/4	3-1/4	3-13/16	7-3/16	1	200
2" - 1729	8-3/4	6-1/2	33-1/2	40-3/4	10-3/4	3-3/8	4-1/8	7-3/16	1-1/4	200
2-1/2" - 1739	10-3/4	7-1/2	40-1/4	50-3/4	15-1/2	3-7/16	5-7/16	8-3/16	1-1/2	400
3" - 1759	11	7-1/2	44	54-1/4	16	3-15/16	5-1/2	8-7/16	1-1/2	500
3" - 1749	11	7-1/2	45-3/4	58	16	3-15/16	5-1/2	8-7/16	1-1/2	500

Dimensions & Weights (USCS) (Contd.)

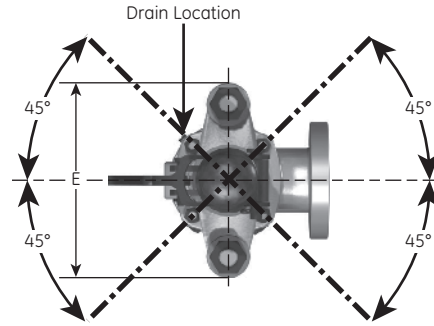
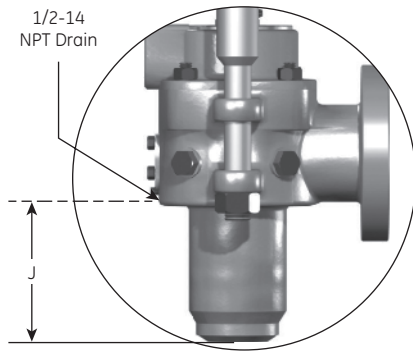

Cap and lever may be rotated 45° horizontally to either side of centerline
Drain location for 4" & 6" valves is on centerline of outlet

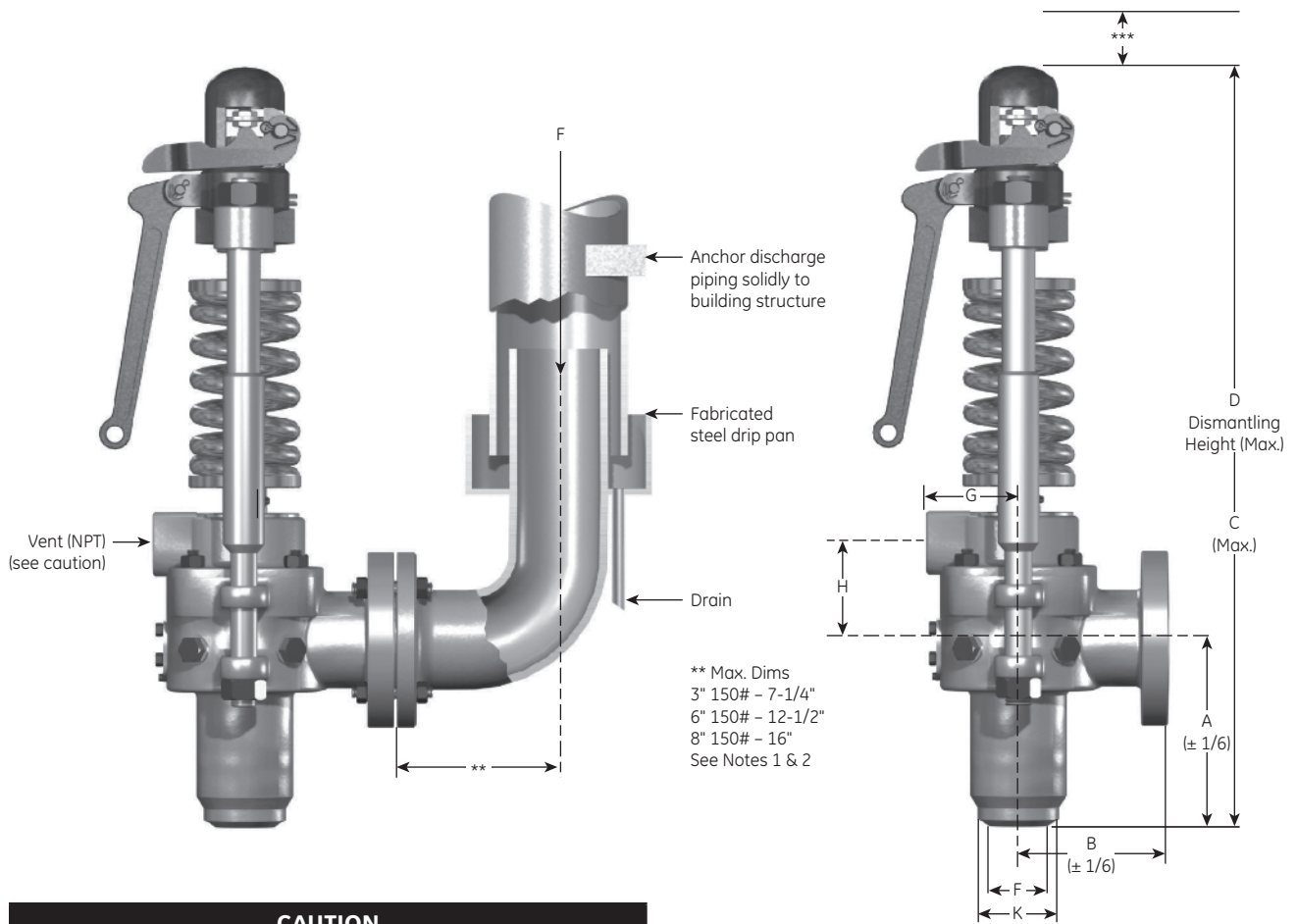

CAUTION

Steam flow will occur through the coverplate vent when the valve is in the open position. Do not plug. Pipe to safe location.

Notes:

1. For lever clearance dimensions see page 31.
2. Appropriate considerations should be made for draining any condensate which may accumulate in the cover plate vent piping, body bowl drain, and drip pan elbow arrangement.

***The EVT-I and Hydroset require 15" clearance.

The EVT-II requires 17" clearance. And an additional 8" is required when the assisted closing device is utilized.

Dimensions & Weights (USCS) (contd.)

Flanged Inlet - Type 17_5W, class 600

Size and Type	All Temperature Classes									Temp. Class to 750°	Temp. Class to 1020°	Temp. Class to 1060°	Vent NPT	Approx. Weight lbs.
	A in.	B in.	C in.	D in.	E in.	F in.	G in.	H in.	J in.	Max. K in. ¹	Max. K in. ¹	Max. K in. ¹		
1-1/2" - 1715W	10	5-1/4	27-3/4	32	9	1-1/2	3-1/4	3-9/16	8-15/16	3.99	3.99	3.99	1	85
2" - 1725W	10	5-1/2	31-1/2	37-1/2	10-1/4	2	3-3/8	4-5/8	8-15/16	3.99	3.99	3.99	1-1/4	100
2-1/2" - 1735W	12	7	37-1/2	44-1/2	13	2-1/2	3-7/16	4-13/16	9-15/16	4.49	4.49	4.98	1-1/4	240
3" - 1755W	12	7	40-3/4	48-1/4	15-1/2	3	3-15/16	5-1/2	9-7/16	5.49	5.49	5.49	1-1/2	260
3" - 1745W	12	7	40-3/4	48-1/4	15-1/2	3	3-15/16	5-1/2	9-7/16	5.74	5.74	5.74	1-1/2	260
4" - 1765W	12	8	43-3/4	52-1/4	15-1/2	4	5-13/16	6-7/8	9-7/16	6.99	6.99	6.99	2	475
4" - 1775W	12	9	48-1/2	58-1/2	19	4-1/8	6	8-3/16	8-9/16	7.24	7.24	7.24	2	550
6" - 1775QW	12	9	48-1/2	58-1/2	19	6	6	8-3/16	8-9/16	8.74	8.74	8.74	2	600
6" - 1785W	12	10	51-3/4	64	20-1/4	6	7-1/4	8-7/16	8-9/16	8.74	8.74	8.74	2-1/2	750
6" - 1705RW	12	10	56-1/4	72-1/4	20-1/4	6	7-1/4	8-7/16	8-9/16	8.74	8.74	8.74	2-1/2	765
6" - 1705RRW	12	10	56-1/4	72-1/4	20-1/4	6	7-1/4	8-7/16	8-9/16	8.74	8.74	8.74	2-1/2	765

Flanged Inlet - Type 17_6W, class 900

Size and Type	All Temperature Classes									Temp. Class to 750°	Temp. Class to 1020°	Temp. Class to 1060°	Vent NPT	Approx. Weight lbs.
	A in.	B in.	C in.	D in.	E in.	F in.	G in.	H in.	J in.	Max. K in. ¹	Max. K in. ¹	Max. K in. ¹		
1-1/2" - 1716W	10	5-1/4	27-3/4	32	9	1-1/2	3-1/4	3-9/16	8-15/16	3.99	3.99	3.99	1	90
2" - 1726W	10	5-1/2	32-3/4	38-1/2	10-1/4	2	3-3/8	4-9/16	8-15/16	3.99	3.99	3.99	1-1/4	110
2-1/2" - 1736W	12	7	38	45-3/4	13	2-1/2	3-7/16	4-13/16	9-15/16	4.49	4.49	4.99	1-1/4	250
3" - 1756W	12	7	41-3/4	50-1/4	15-1/2	3	3-15/16	5-1/2	9-7/16	5.49	5.49	5.49	1-1/2	360
3" - 1746W	12	7	41-3/4	50-1/4	15-1/2	3	3-15/16	5-1/2	9-7/16	5.74	5.74	5.74	1-1/2	360
4" - 1766W	12	8	45-1/2	56	15-1/2	4	5-13/16	6-7/8	9-7/16	6.99	6.99	6.99	2	500
4" - 1776W	12	9	50-1/2	62-1/2	19	4-1/8	6	8-3/16	8-9/16	7.24	7.24	7.24	2	575
6" - 1776QW	12	9	50-1/2	62-1/2	19	6	6	8-3/16	8-9/16	8.74	8.74	8.74	2	640
6" - 1786W	12	10-1/2	64	71	21-1/2	6	7-1/4	9-7/16	10-9/16	8.74	8.74	8.74	2-1/2	1100
6" - 1706RW	12	10-1/2	64	71	21-1/2	6	7-1/6	8-9/16	10-9/16	8.74	8.74	8.74	2-1/2	1132
6" - 1706RRW	12	10-1/2	64	71	21-1/2	6	7-1/6	8-9/16	10-9/16	8.74	8.74	8.74	2-1/2	1132

Flanged Inlet - Type 17_7W, class 1500

Size and Type	All Temperature Classes									Temp. Class to 750°	Temp. Class to 1020°	Temp. Class to 1060°	Vent NPT	Approx. Weight lbs.
	A in.	B in.	C in.	D in.	E in.	F in.	G in.	H in.	J in.	Max. K in. ¹	Max. K in. ¹	Max. K in. ¹		
1-1/2" - 1717W	10	5-1/4	29-1/2	35-1/2	9	1-1/2	3-1/4	3-21/32	8-15/16	3.99	3.99	3.99	1	90
2" - 1727W	10	5-1/2	34-1/4	41-1/2	10-1/4	2	3-3/8	3-23/32	8-15/16	4.49	4.49	4.49	1-1/4	140
2-1/2" - 1737W	12	7	38	45-3/4	13	2-1/2	3-7/16	4-29/32	9-15/16	4.99	4.99	5.49	1-1/4	250
3" - 1757W	12	7	43-1/2	59	15-1/2	3	3-5/16	5-19/32	9-7/16	5.49	5.49	6.49	1-1/2	380
3" - 1747W	12	7	43-1/2	59	15-1/2	3	3-5/16	5-19/32	9-7/16	5.74	5.74	6.49	1-1/2	380
4" - 1767W	12	8	47-1/2	60	15-1/2	4	5-13/16	6-7/8	9-7/16	6.99	6.99	7.24	2	525
6" - 1777QW	12	10	55-1/4	61-3/4	19-3/4	6	7-1/4	8-7/16	8-9/16	8.74	8.74	8.74	2-1/2	785
6" - 1787W	16	10-1/2	67-7/8	77-3/8	21-1/2	6	7-1/16	8-9/16	11-9/16	8.74	8.74	8.74	2-1/2	1100
6" - 1707RW	16	10-1/2	67-7/8	77-3/8	21-1/2	6	7-1/16	8-9/16	11-9/16	8.74	8.74	8.74	2-1/2	1132
6" - 1707RRW	16	10-1/2	67-7/8	77-3/8	21-1/2	6	7-1/16	8-9/16	11-9/16	8.74	8.74	8.74	2-1/2	1132

Note:

- Maximum nominal "K" dimension based on standard inlet neck outside diameter. Oversize inlet necks also available (consult factory).
Butt weld configuration is dependent upon set pressure and customer's required configuration.

Dimensions & Weights (USCS) (Contd.)

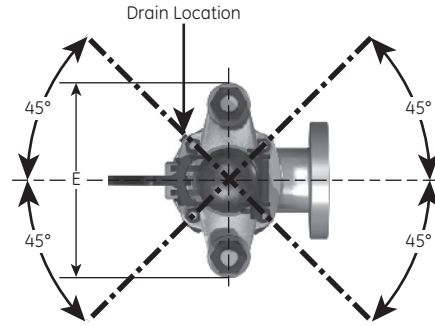
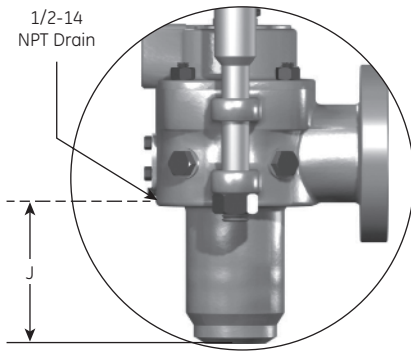

Cap and lever may be rotated 45° horizontally to either side of centerline
 Drain location for 4" & 6" valves is on centerline of outlet

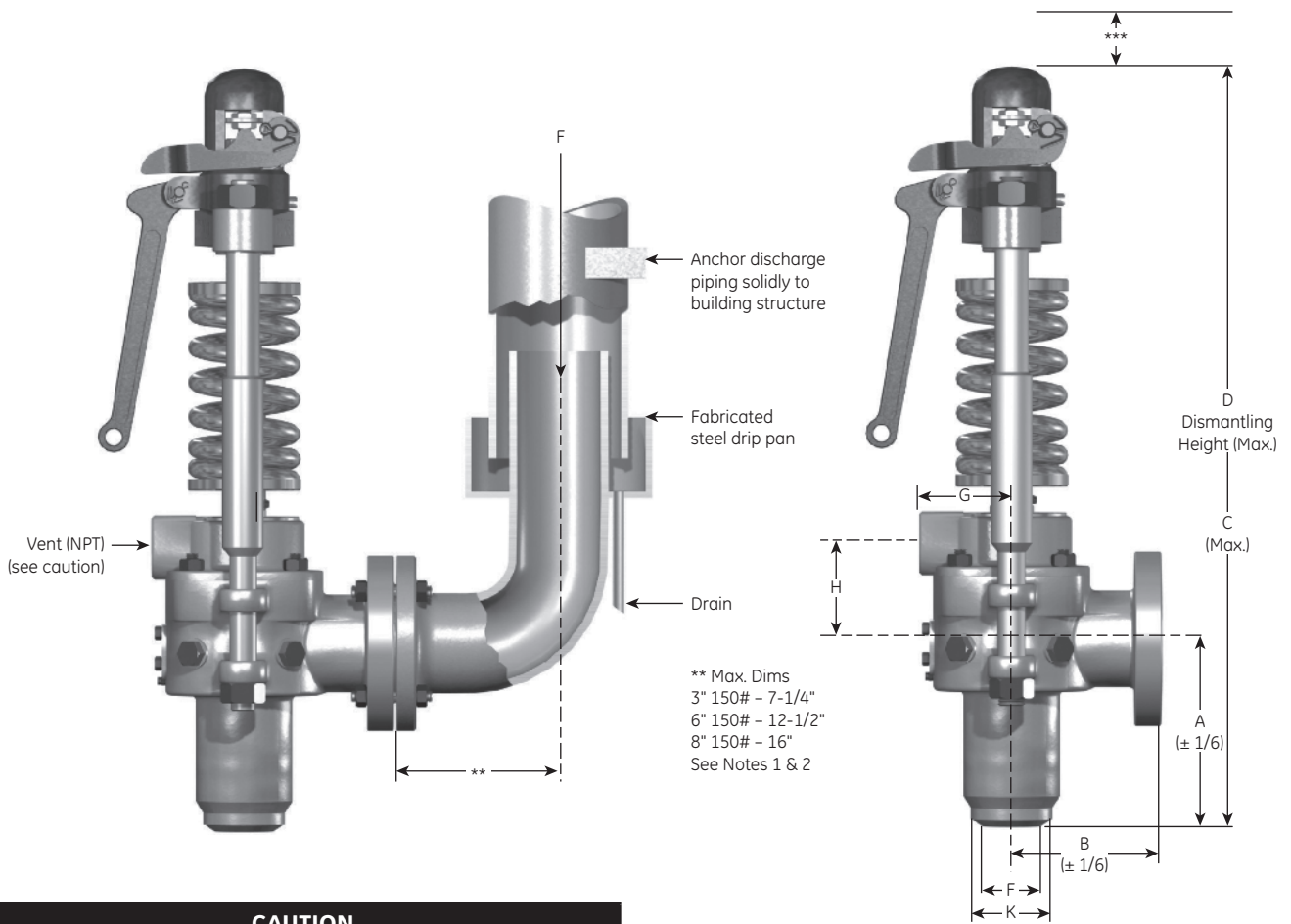

** Max. Dims
 3" 150# - 7-1/4"
 6" 150# - 12-1/2"
 8" 150# - 16"
 See Notes 1 & 2

***The EVT-I and Hydroset require 15" clearance.
 The EVT-II requires 17" clearance. And an additional 8" is required when the assisted closing device is utilized.

CAUTION

Steam flow will occur through the coverplate vent when the valve is in the open position. Do not plug. Pipe to safe location.

- Notes:
1. For lever clearance dimensions see page 31.
 2. Appropriate considerations should be made for draining any condensate which may accumulate in the cover plate vent piping, body bowl drain, and drip pan elbow arrangement.

Dimensions & Weights (USCS) (Contd.)

Welded Inlet - Type 17_9W, class 2500

Size and Type	All Temperature Classes									Temp. Class to 750°	Temp. Class to 1020°	Temp. Class to 1060°	Vent NPT	Approx. Weight lbs.
	A in.	B in.	C in.	D in.	E in.	F in.	G in.	H in.	J in.	Max. K in. ¹	Max. K in. ¹	Max. K in. ¹		
1-1/2" - 1719W	10	6-1/2	31-1/2	37-1/4	10-3/4	1-1/2	3-1/4	3-13/16	8-7/16	3.99	3.99	4.49	1	190
2" - 1729W	10	6-1/2	34-3/4	42	10-3/4	2	3-3/8	4-1/8	8-7/16	4.99	4.99	5.49	1-1/4	200
2-1/2" - 1739W	12	7-1/2	41-1/2	50	15-1/2	2-1/2	3-7/16	5-7/16	9-7/16	5.99	5.99	5.99	1-1/4	400
3" - 1759W	12	7-1/2	45	55-1/4	16	3	3-15/16	5-1/2	9-7/16	6.49	6.49	6.99	1-1/2	470
3" - 1749W	12	7-1/2	46-3/4	59	16	3	3-15/16	5-1/2	9-7/16	6.49	6.49	7.24	1-1/2	470

Welded Inlet - Type 17_0W, class 3000

Size and Type	All Temperature Classes									Temp. Class to 750°	Temp. Class to 1020°	Temp. Class to 1060°	Vent NPT	Approx. Weight lbs.
	A in.	B in.	C in.	D in.	E in.	F in.	G in.	H in.	J in.	Max. K in. ¹	Max. K in. ¹	Max. K in. ¹		
1-1/2" - 1710W	10	6-1/2	31-1/2	37-1/4	10-3/4	1-1/2	3-1/4	3-13/16	8-7/16	4.49	4.49	4.99	1	190
2" - 1720W	10	6-1/2	34-3/4	42	10-3/4	2	3-3/8	4-1/8	8-7/16	4.99	4.99	5.49	1-1/4	200
2-1/2" - 1730W	10	7-1/2	43-1/2	54	15-1/2	2-1/2	3-7/16	5-7/16	9-7/16	5.99	5.99	6.49	1-1/4	400
3" - 1750W	12	7-1/2	47	59-1/4	16	3	3-15/16	5-1/2	9-7/16	6.49	6.49	7.24	1-1/2	480
3" - 1740W	12	7-1/2	47	59-1/4	16	3	3-15/16	5-1/2	9-7/16	6.74	6.74	7.49	1-1/2	480
4" - 1760W	12	9-11/16	65-1/8	76	22-3/4	4	5-13/16	8-1/8	8-3/16	10.49	10.49	10.49	2	1250

Welded Inlet - Type 17_3W, class 4500

Size and Type	All Temperature Classes									Temp. Class to 750°	Temp. Class to 1020°	Temp. Class to 1060°	Vent NPT	Approx. Weight lbs.
	A in.	B in.	C in.	D in.	E in.	F in.	G in.	H in.	J in.	Max. K in. ¹	Max. K in. ¹	Max. K in. ¹		
1-1/2" - 1713W	10	6-1/2	34-3/4	42	10-3/4	1-1/2	3-1/4	3-43/64	8-7/16	5.49	5.49	5.49	1-1/4	250
2" - 1723W	10	7-1/2	45-1/4	55-3/4	15-1/2	2	3-7/16	5-7/16	9-7/16	6.49	6.49	6.49	1-1/2	375
2-1/2" - 1733W	12	7-1/2	51-3/4	65-1/2	16	2-1/2	3-15/16	5-1/2	9-7/16	6.99	6.99	6.99	1-1/2	475
3" - 1753W	14	8	56-1/2	70-1/2	19-1/4	3	4-5/16	5-5/8	11-7/16	7.99	7.99	7.99	1-1/2	575
3" - 1743W	14	8	58	70-1/2	19-1/4	3	4-5/16	5-5/8	11-7/16	7.99	7.99	7.99	1-1/2	600

Note:

- Maximum nominal "K" dimension based on standard inlet neck outside diameter. Oversize inlet necks also available (consult factory).
Butt weld configuration is dependent upon set pressure and customer's required configuration.

Dimensions & Weights (Metric)

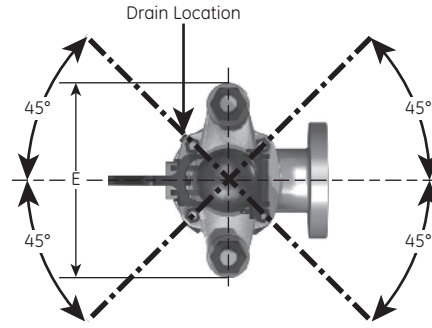
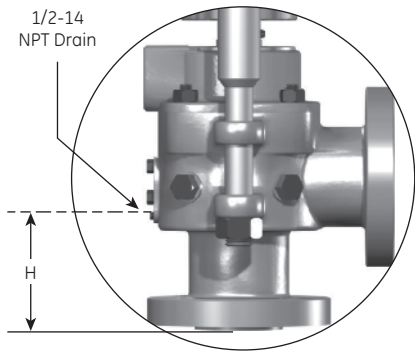

Cap and lever may be rotated 45° horizontally to either side of centerline
 Drain location for 4" & 6" valves is on centerline of outlet

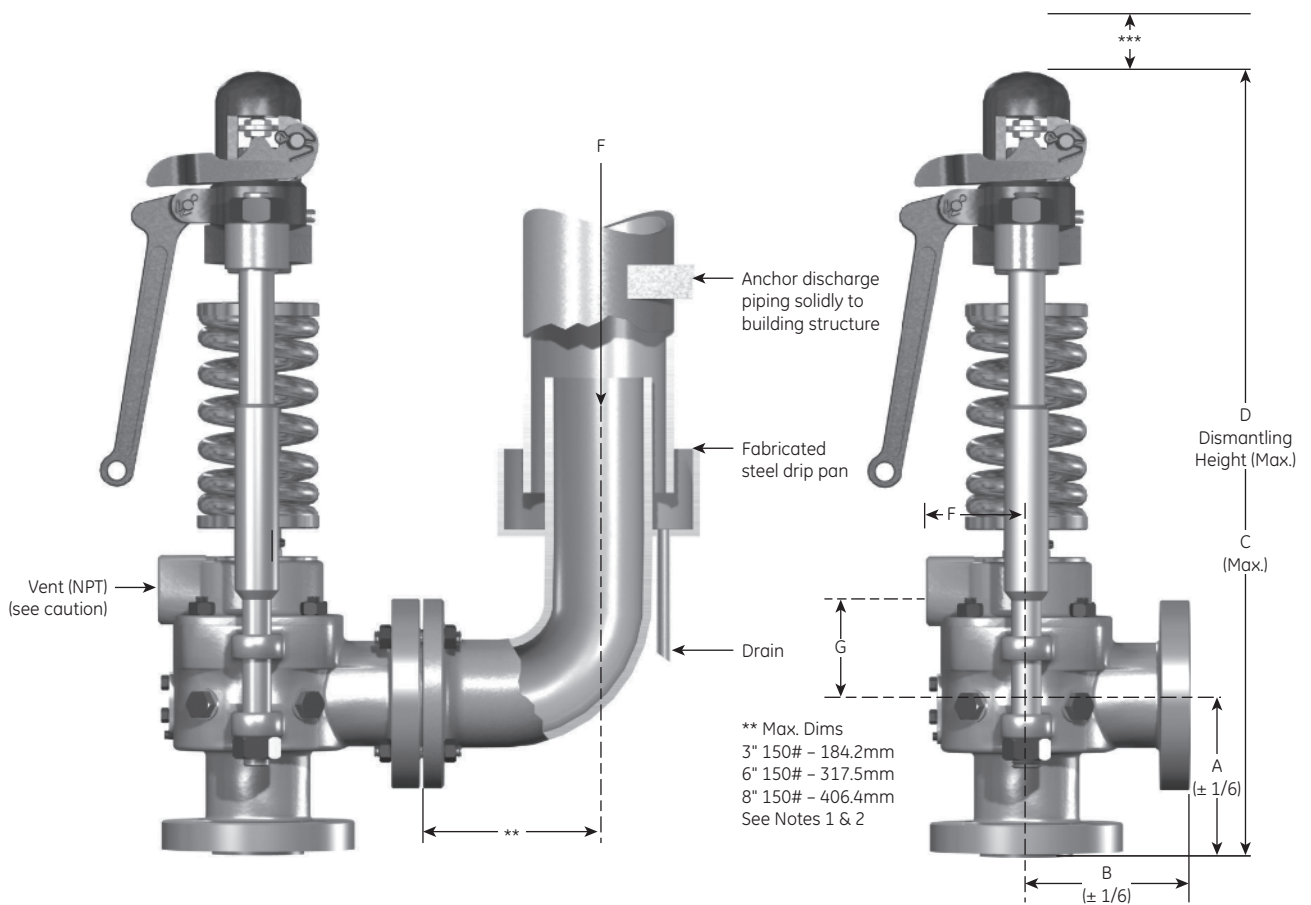

CAUTION

Steam flow will occur through the coverplate vent when the valve is in the open position. Do not plug. Pipe to safe location.

***The EVT-I and Hydroset require 15" clearance.

The EVT-II requires 17" clearance. And an additional 8" is required when the assisted closing device is utilized.

Notes:

1. For lever clearance dimensions see page 31.
2. Appropriate considerations should be made for draining any condensate which may accumulate in the cover plate vent piping, body bowl drain, and drip pan elbow arrangement.

Dimensions & Weights (Metric)

Flanged Inlet - Type 17_5, class 600

Size and Type	All Temperature Classes								Vent NPT	Approx. Weight lbs.
	A mm	B mm	C mm	D mm	E mm	F mm	G mm	H mm		
1-1/2" - 1715	152.4	133.4	603.3	711.2	228.6	82.6	90.5	125.4	1	38.6
2" - 1725	177.8	139.7	723.9	876.3	260.4	85.7	117.5	150.8	1-1/4	45.4
2-1/2" - 1735	209.6	177.8	850.9	1035.1	330.2	87.3	122.2	157.2	1-1/4	108.9
3" - 1755	215.9	177.8	946.2	1136.7	393.7	100.0	139.7	150.8	1-1/2	129.3
3" - 1745	215.9	177.8	946.2	1136.7	393.7	100.0	139.7	150.8	1-1/2	129.3
4" - 1765	228.6	203.2	1035.1	1251.0	393.7	147.6	174.6	163.5	2	215.5
4" - 1775	222.3	228.6	1149.4	1403.4	482.6	152.4	207.9	134.9	2	249.5
6" - 1775Q	322.3	228.6	1251.0	1505.0	482.6	152.4	207.9	235.0	2	272.2
6" - 1785	271.5	254.0	1282.7	1593.9	514.4	184.2	214.3	184.2	2-1/2	340.2
6" - 1705R	271.5	254.0	1403.4	1809.8	514.4	184.2	214.3	184.2	2-1/2	347.0
6" - 1705RR	271.5	254.0	1403.4	1809.8	514.4	184.2	214.3	184.2	2-1/2	347.0

Flanged Inlet - Type 17_6, class 900

Size and Type	All Temperature Classes								Vent NPT	Approx. Weight lbs.
	A mm	B mm	C mm	D mm	E mm	F mm	G mm	H mm		
1-1/2" - 1716	152.4	133.4	603.3	711.2	228.6	82.6	90.5	125.4	1	40.8
2" - 1726	177.8	139.7	755.7	901.7	260.4	85.7	117.5	150.8	1-1/4	49.9
2-1/2" - 1736	209.6	177.8	870.0	1066.8	330.2	87.3	122.2	157.2	1-1/4	113.4
3" - 1756	219.1	177.8	977.9	1187.5	393.7	100.0	139.7	154.0	1-1/2	174.6
3" - 1746	219.1	177.8	977.9	1187.5	393.7	100.0	139.7	154.0	1-1/2	174.6
4" - 1766	231.8	203.2	1085.9	1352.6	393.7	147.6	174.6	166.7	2	226.8
4" - 1776	228.6	228.6	1206.5	1511.3	482.6	152.4	207.9	141.3	2	260.8
6" - 1776Q	330.2	228.6	1308.1	1612.9	482.6	152.4	207.9	236.5	2	290.3
6" - 1786-HP	392.1	266.7	1636.7	1814.5	546.1	179.4	217.5	279.4	2-1/2	544.0
6" - 1706R-HP	392.1	266.7	1636.7	1814.5	546.1	179.4	217.5	279.4	2-1/2	544.0
6" - 1706RR-HP	392.1	266.7	1636.7	1814.5	546.1	179.4	217.5	279.4	2-1/2	544.0

Flanged Inlet - Type 17_7, class 1500

Size and Type	All Temperature Classes								Vent NPT	Approx. Weight lbs.
	A mm	B mm	C mm	D mm	E mm	F mm	G mm	H mm		
1-1/2" - 1717	152.4	133.4	647.7	800.1	228.6	82.6	90.5	125.4	1	40.8
2" - 1727	177.8	139.7	793.8	977.9	260.4	85.7	117.5	150.8	1-1/4	63.5
2-1/2" - 1737	209.6	177.8	870.0	1066.8	330.2	87.3	122.2	157.2	1-1/4	113.4
3" - 1757	228.6	177.8	1028.7	1295.4	393.7	100.0	139.7	188.9	1-1/2	181.4
3" - 1747	228.6	177.8	1028.7	1295.4	393.7	100.0	139.7	163.5	1-1/2	181.4
4" - 1767	241.3	203.2	1143.0	1460.5	393.7	147.6	174.6	176.2	2	272.2
6" - 1777Q	362.0	254.0	1460.5	1866.9	501.7	184.2	214.3	274.6	2-1/2	385.6
6" - 1787	419.1	266.7	1736.7	1978.0	546.1	179.4	217.5	306.4	2-1/2	581.0
6" - 1707R	419.1	266.7	1736.7	1978.0	546.1	179.4	217.5	306.4	2-1/2	595.0
6" - 1707RR	419.1	266.7	1734.7	1978.0	546.1	179.4	217.5	306.4	2-1/2	595.0

Flanged Inlet - Type 17_9, class 2500

Size and Type	All Temperature Classes								Vent NPT	Approx. Weight lbs.
	A mm	B mm	C mm	D mm	E mm	F mm	G mm	H mm		
1-1/2" - 1719	222.3	165.1	768.4	914.4	273.1	82.6	96.8	182.6	1	91.0
2" - 1729	222.3	165.1	850.9	1035.1	273.1	85.7	104.8	182.6	1-1/4	91.0
2-1/2" - 1739	273.1	190.5	1022.4	1289.1	393.7	87.3	138.1	207.9	1-1/2	181.4
3" - 1759	279.4	190.5	1117.6	1378.4	406.4	100.0	139.7	214.3	1-1/2	226.8
3" - 1749	279.4	190.5	1162.1	1473.2	406.4	100.0	139.7	214.3	1-1/2	226.8
4" - 1769	292.1	219.1	1454.2	1866.9	393.7	147.6	200.0	198.4	2"-11-1/2	317.5

Dimensions & Weights (Metric) (Contd.)

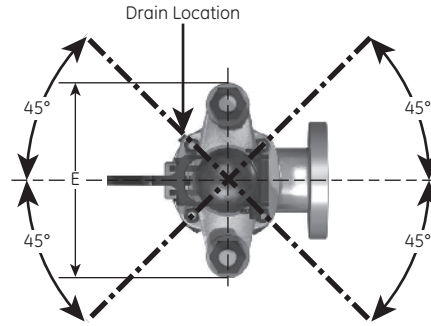
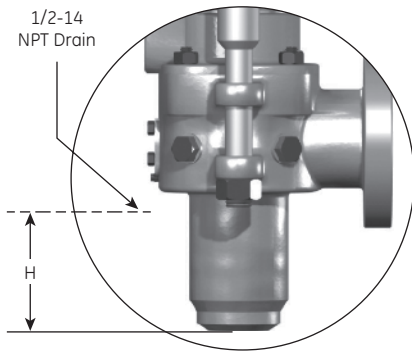

Cap and lever may be rotated 45° horizontally to either side of centerline
Drain location for 4" & 6" valves is on centerline of outlet

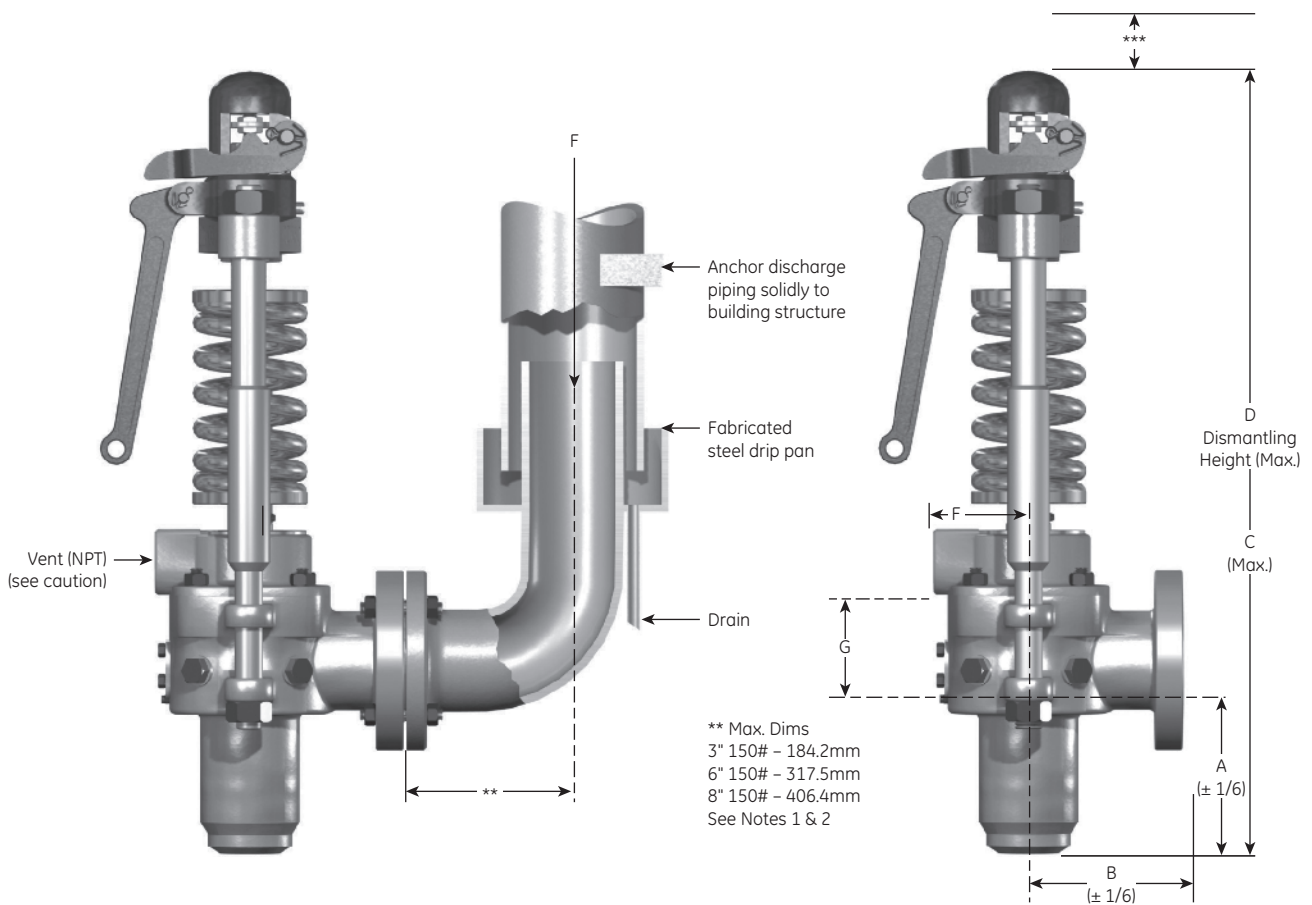

CAUTION

Steam flow will occur through the coverplate vent when the valve is in the open position. Do not plug. Pipe to safe location.

***The EVT-I and Hydroset require 381mm clearance.

The EVT-II requires 432mm clearance. And an additional 203mm is required when the assisted closing device is utilized.

Notes:

1. For lever clearance dimensions see page 31.
2. Appropriate considerations should be made for draining any condensate which may accumulate in the cover plate vent piping, body bowl drain, and drip pan elbow arrangement.

Dimensions & Weights (Metric) (Contd.)

Flanged Inlet - Type 17_5W, class 600

Size and Type	All Temperature Classes									Temp. Class to 399°	Temp. Class to 549°	Temp. Class to 571°	Vent NPT	Approx. Weight lbs.
	A mm	B mm	C mm	D mm	E mm	F mm	G mm	H mm	J mm	Max. K in. ¹	Max. K in. ¹	Max. K in. ¹		
1-1/2" - 1715W	254.0	133.4	704.9	812.8	228.6	38.1	82.6	90.5	227.0	3.99	3.99	3.99	1	38.6
2" - 1725W	254.0	139.7	800.1	952.5	260.4	50.8	85.7	117.5	227.0	3.99	3.99	3.99	1-1/4	45.4
2-1/2" - 1735W	304.8	177.8	946.2	1130.3	330.2	63.5	87.3	122.2	252.4	4.49	4.98	4.98	1-1/4	108.9
3" - 1755W	304.8	177.8	1035.1	1225.6	393.7	76.2	100.0	139.7	239.7	5.49	5.49	5.49	1-1/2	118.0
3" - 1745W	304.8	177.8	1035.1	1225.6	393.7	76.2	100.0	139.7	239.7	5.74	5.74	5.74	1-1/2	118.0
4" - 1765W	304.8	203.2	1111.3	1327.2	393.7	101.6	147.6	174.6	239.7	6.99	6.99	6.99	2	215.5
4" - 1775QW	304.8	228.6	1231.9	1485.9	482.6	104.8	152.4	208.0	217.5	7.24	7.24	7.24	2	249.5
6" - 1775QW	304.8	228.6	1231.9	1485.9	482.6	152.4	152.4	208.0	217.5	8.74	8.74	8.74	2	272.2
6" - 1785W	304.8	254.0	1314.5	1625.6	514.4	152.4	184.2	214.3	217.5	8.74	8.74	8.74	2-1/2	340.2
6" - 1705RW	304.8	254.0	1428.8	1835.2	514.4	152.4	184.2	214.3	217.5	8.74	8.74	8.74	2-1/2	347.0
6" - 1705RRW	304.8	254.0	1428.8	1835.2	514.4	152.4	184.2	214.3	217.5	8.74	8.74	8.74	2-1/2	347.0

Flanged Inlet - Type 17_6W, class 900

Size and Type	All Temperature Classes									Temp. Class to 399°	Temp. Class to 549°	Temp. Class to 571°	Vent NPT	Approx. Weight lbs.
	A mm	B mm	C mm	D mm	E mm	F mm	G mm	H mm	J mm	Max. K in. ¹	Max. K in. ¹	Max. K in. ¹		
1-1/2" - 1716W	254.0	133.4	704.9	812.8	228.6	38.1	82.6	90.5	227.0	3.99	3.99	3.99	1	40.8
2" - 1726W	254.0	139.7	831.9	977.9	260.4	50.8	85.7	117.5	227.0	3.99	3.99	3.99	1-1/4	50.0
2-1/2" - 1736W	304.8	177.8	965.2	1162.1	330.2	63.5	87.3	122.2	252.4	4.49	4.98	4.98	1-1/4	113.4
3" - 1756W	304.8	177.8	1060.5	1276.4	393.7	76.2	100.0	139.7	239.7	5.49	5.49	5.49	1-1/2	163.3
3" - 1746W	304.8	177.8	1060.5	1276.4	393.7	76.2	100.0	139.7	239.7	5.74	5.74	5.74	1-1/2	163.3
4" - 1766W	304.8	203.2	1155.7	1422.4	393.7	101.6	147.6	174.6	239.7	6.99	6.99	6.99	2	226.8
4" - 1776QW	304.8	228.6	1282.7	1587.5	482.6	104.8	152.4	208.0	217.5	7.24	7.24	7.24	2	260.8
6" - 1776QW	304.8	228.6	1282.7	1587.5	482.6	152.4	152.4	208.0	217.5	8.74	8.74	8.74	2	290.3
6" - 1786W-HP	381.0	266.7	1625.6	1803.4	546.1	152.4	184.2	214.3	268.3	8.74	8.74	8.74	2-1/2	499.0
6" - 1706RW-HP	381.0	266.7	1625.6	1803.4	546.1	152.4	179.4	214.3	268.3	8.74	8.74	8.74	2-1/2	513.5
6" - 1706RRW-HP	381.0	266.7	1625.6	1803.4	546.1	152.4	179.4	214.3	268.3	8.74	8.74	8.74	2-1/2	513.5

Flanged Inlet - Type 17_7W, class 1500

Size and Type	All Temperature Classes									Temp. Class to 399°	Temp. Class to 549°	Temp. Class to 571°	Vent NPT	Approx. Weight lbs.
	A in.	B in.	C in.	D in.	E in.	F in.	G in.	H in.	J in.	Max. K in. ¹	Max. K in. ¹	Max. K in. ¹		
1-1/2" - 1717W	254.0	133.4	749.3	901.7	228.6	38.1	82.6	92.8	227.0	3.99	3.99	3.99	1	40.8
2" - 1727W	254.0	139.7	870.0	1054.1	260.4	50.8	85.7	94.4	227.0	4.49	4.49	4.49	1-1/4	63.5
2-1/2" - 1737W	304.8	177.8	965.2	1162.1	330.2	63.5	87.3	124.6	252.4	4.99	4.99	5.49	1-1/2	113.4
3" - 1757W	304.8	177.8	1104.9	1498.6	393.7	76.2	100.0	142.0	239.7	5.49	5.49	6.49	1-1/2	172.4
3" - 1747W	304.8	177.8	1104.9	1498.6	393.7	76.2	100.0	142.0	239.7	5.74	5.74	6.49	1-1/2	172.4
4" - 1767W	304.8	203.2	1206.5	1524.0	393.7	101.6	147.6	174.6	239.7	6.99	6.99	7.24	2	238.1
6" - 1777QW	304.8	254.0	1403.4	1568.5	501.7	152.4	184.2	214.3	217.5	8.74	8.74	8.74	2-1/2	356.1
6" - 1787W	406.4	266.7	1724.0	1965.3	546.1	152.4	179.4	293.7	293.7	8.74	8.74	8.74	2-1/2	499.0
6" - 1707RW	406.4	266.7	1724.0	1965.3	546.1	152.4	179.4	293.7	293.7	8.74	8.74	8.74	2-1/2	513.5
6" - 1707RRW	406.4	266.7	1724.0	1965.3	546.1	152.4	179.4	293.7	293.7	8.74	8.74	8.74	2-1/2	513.5

Note:

1. Maximum nominal "K" dimension based on standard inlet neck outside diameter. Oversize inlet necks also available (consult factory).
Butt weld configuration is dependent upon set pressure and customer's required configuration.

Dimensions & Weights (Metric) (Contd.)

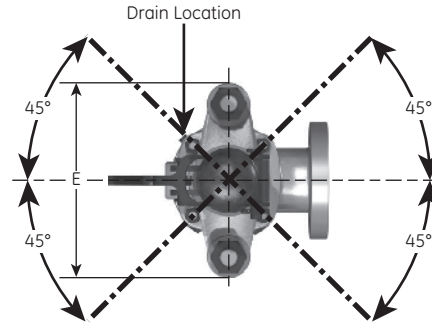
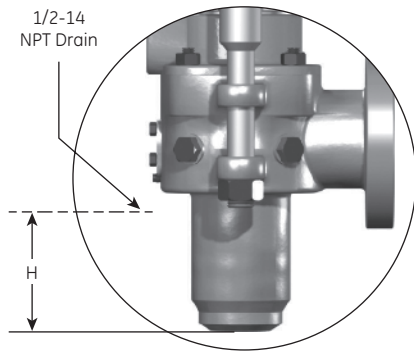

Cap and lever may be rotated 45° horizontally to either side of centerline
Drain location for 4" & 6" valves is on centerline of outlet

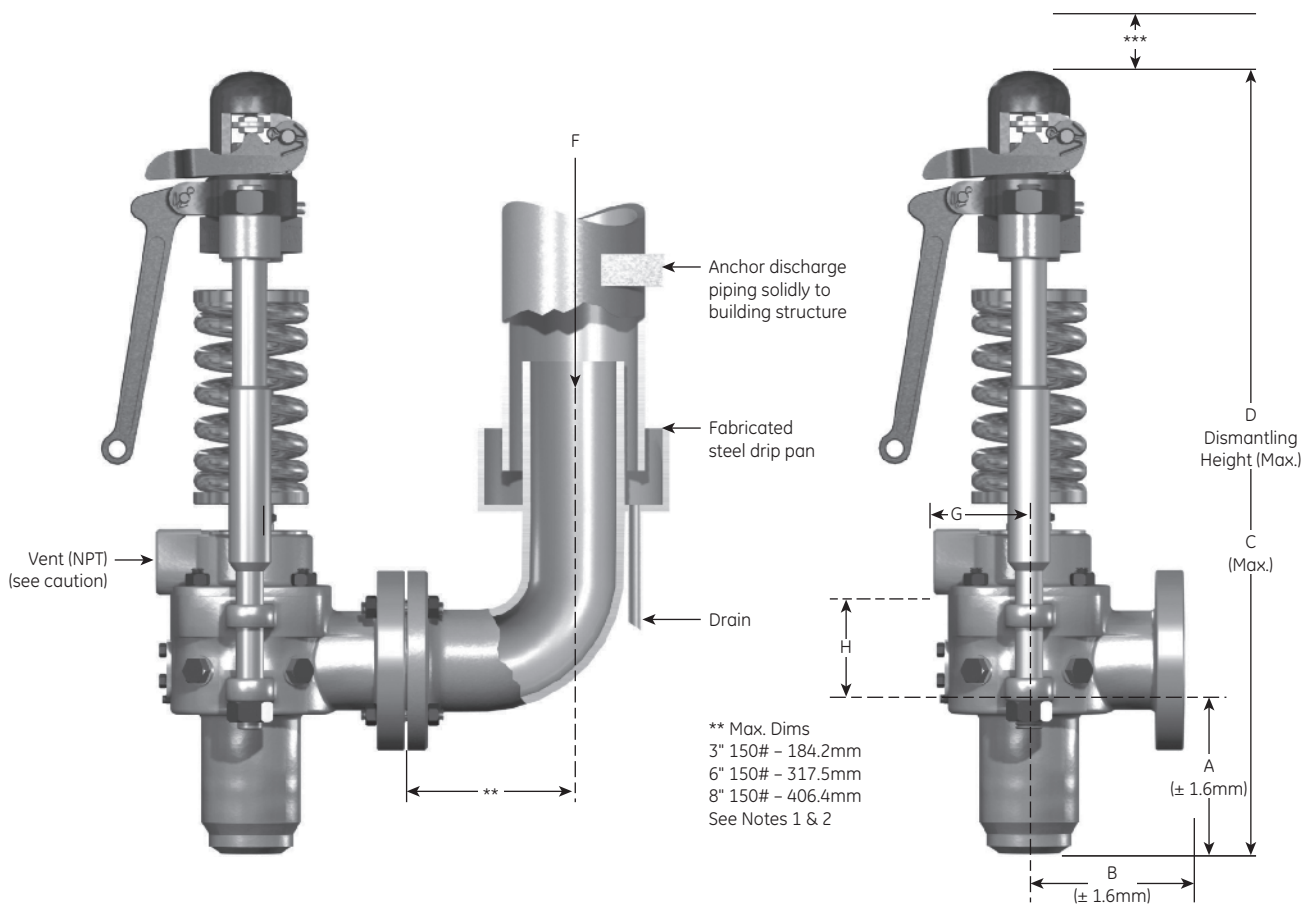

CAUTION

Steam flow will occur through the coverplate vent when the valve is in the open position. Do not plug. Pipe to safe location.

***The EVT-I and Hydroset require 381mm clearance.

The EVT-II requires 432mm clearance. And an additional 203mm is required when the assisted closing device is utilized.

Notes:

1. For lever clearance dimensions see page 31.
2. Appropriate considerations should be made for draining any condensate which may accumulate in the cover plate vent piping, body bowl drain, and drip pan elbow arrangement.

Dimensions & Weights (Metric) (Contd.)

Welded Inlet – Type 17_9W, class 2500

Size and Type	All Temperature Classes									Temp. Class to 399°C	Temp. Class to 549°C	Temp. Class to 571°C	Vent NPT	Approx. Weight lbs.
	A mm	B mm	C mm	D mm	E mm	F mm	G mm	H mm	J mm	Max. K in. ¹	Max. K in. ¹	Max. K in. ¹		
1-1/2" - 1719W	254.0	165.1	800.1	946.2	273.1	38.1	82.6	96.8	214.3	3.99	3.99	4.49	1	86.2
2" - 1729W	254.0	165.1	882.7	1066.8	273.1	50.8	85.7	104.8	214.3	4.99	4.99	5.49	1-1/4	90.7
2-1/2" - 1739W	304.8	190.5	1054.1	1270.0	393.7	63.5	87.3	138.1	239.7	5.99	5.99	5.99	1-1/2	181.4
3" - 1759W	304.8	190.5	1143.0	1403.4	406.4	76.2	100.0	139.7	239.7	6.49	6.49	6.99	1-1/2	213.2
3" - 1749W	304.8	190.5	1187.5	1498.6	406.4	76.2	100.0	139.7	239.7	6.49	6.49	7.24	1-1/2	213.2

Welded Inlet – Type 17_0W, class 3000

Size and Type	All Temperature Classes									Temp. Class to 399°C	Temp. Class to 549°C	Temp. Class to 571°C	Vent NPT	Approx. Weight lbs.
	A mm	B mm	C mm	D mm	E mm	F mm	G mm	H mm	J mm	Max. K in. ¹	Max. K in. ¹	Max. K in. ¹		
1-1/2" - 1710W	254.0	165.1	800.1	946.2	273.1	38.1	82.6	96.8	214.3	4.49	4.49	4.99	1	86.2
2" - 1720W	254.0	165.1	882.7	1066.8	273.1	50.8	85.7	104.8	214.3	4.99	4.99	5.49	1-1/4	90.7
2-1/2" - 1730W	304.8	191.0	1104.9	1371.6	393.7	63.5	87.3	138.1	239.7	5.99	5.99	6.49	1-1/4	181.4
3" - 1750W	304.8	191.0	1193.8	1505.0	406.4	76.2	100.0	139.7	239.7	6.49	6.49	7.24	1-1/2	217.7
3" - 1740W	304.8	191.0	1193.8	1505.0	406.4	76.2	100.0	139.7	239.7	6.74	6.74	7.49	1-1/2	217.7
4" - 1760W	304.8	246.0	1654.2	1930.4	577.9	101.6	147.6	206.4	208.0	10.49	10.49	10.49	2	567.0

Welded Inlet – Type 17_3W, class 4500

Size and Type	All Temperature Classes									Temp. Class to 399°C	Temp. Class to 549°C	Temp. Class to 571°C	Vent NPT	Approx. Weight lbs.
	A mm	B mm	C mm	D mm	E mm	F mm	G mm	H mm	J mm	Max. K in. ¹	Max. K in. ¹	Max. K in. ¹		
1-1/2" - 1713W	254.0	165.1	882.7	1066.8	273.1	38.1	82.6	93.2	214.3	5.49	5.49	5.49	1-1/4	113.4
2" - 1723W	304.8	190.5	1149.4	1416.1	393.7	50.8	87.3	138.1	239.7	6.49	6.49	6.49	1-1/2	170.1
2-1/2" - 1733W	304.8	190.5	1314.5	1663.7	406.4	63.5	100.0	139.7	239.7	6.99	6.99	6.99	1-1/2	215.5
3" - 1753W	355.6	203.2	1435.1	1790.7	489.0	76.2	109.5	142.9	290.5	7.99	7.99	7.99	1-1/2	260.8
3" - 1743W	355.6	203.2	1473.2	1841.5	489.0	76.2	109.5	142.9	290.5	7.99	7.99	7.99	1-1/2	272.2

Note:

1. Maximum nominal "K" dimension based on standard inlet neck outside diameter. Oversize inlet necks also available (consult factory).
Butt weld configuration is dependent upon set pressure and customer's required configuration.

Dimensions & Weights (Metric) (Contd.)

Lever Clearance Dimensions (US & metric units)

Size and Type	B in. mm	C in. mm	D in. mm	E in. mm
1-1/2" - 1715, 1716, 1717	8	1-15/16	3-9/16	4-1/8
2" - 1725	203.2	49.2	90.5	104.8
1-1/2" - 1710, 1719	11-3/4	2-1/2	4-1/8	3-7/8
2" - 1726, 1727	298.5	63.5	104.8	98.4
2-1/2" - 1735				
1-1/2" - 1713	11-3/4	2-11/16	4-3/8	5-7/8
2" - 1720, 1729	298.5	68.2	111.1	149.2
2-1/2" - 1736, 1737				
4" - 1760	32	3-5/8	6-1/4	9-1/4
	812.8	92.1	158.8	235.0
2" - 1723	18-1/8	3-1/16	5-5/8	8-5/16
3" - 1745, 1746, 1747,				
2-1/2" - 1730, 1739	460.4	77.8	142.9	211.1
4" - 1765, 1766, 1767				
2-1/2" - 1733	18-1/4	3-5/8	6-1/4	9-1/8
3" - 1740, 1743				
	463.6	92.1	158.8	231.8
1749, 1750, 1753, 1759				
4" - 1775Q	18-1/4	3-5/8	6-1/4	7-1/8
6" - 1775Q	463.6	92.1	158.8	181.0
6" - 1705R, 1706R, 1777Q, 1785, 1786, 1705RR	18-1/4	3-5/8	6-1/4	10-7/8
	463.6	92.1	158.8	276.2
4" - 1776Q	22-3/4	3-5/8	6-1/4	7-1/4
6" - 1776Q	577.9	92.1	158.8	184.1
6" - 1706R-HP, 1707R, 1786-HP, 1787	32	3-5/8	6-1/4	9-7/32
6" - 1706RR-HP, 6-1707RR	812.8	92.1	158.8	234.1

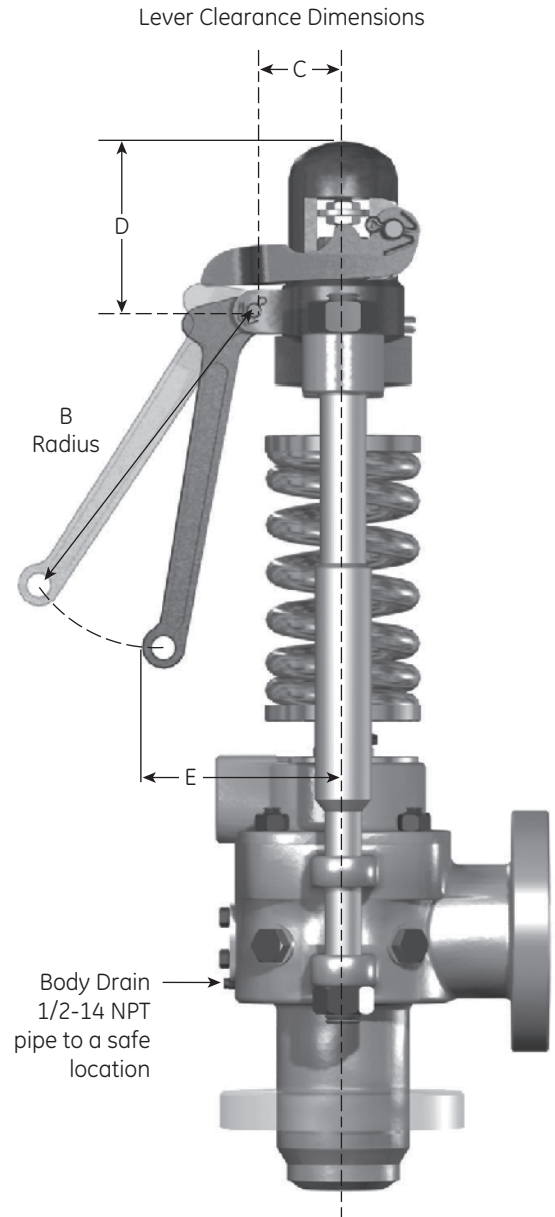

Pressure/Temperature (USCS)

Set pressure limits (psig) for 1700 flanged & buttweld safety valves at designated temperature (°F)

Meets ASME B&PVC Section I and ASME B16.34

600 Pressure Class

Temperature Class			B	B	B	B	D	D	D	D	D	D	E	F	G	H	J
Base Material Flanged			WC6	WC6	WC6	WC6	WC6	WC6	WC6	WC6	WC6	WC6	WC9	WC9	CF8M	-	-
Base Material ButtWeld			WCC	WCC	WCC	WCC	WC6	WC6	WC6	WC6	WC6	WC6	WC9	WC9	CF8M	WC9	WC9
Inlet Neck Material			A105	A105	A105	A105	F11	F11	F11	F11	F11	F11	F22	F22	F316	F91	F92
ButtWeld ^{1&2}			A105	A105	A105	A105	F11	F11	F11	F11	F11	F11	F22	F22	F316	F91	F92
Valve Type	Inlet CL_600	Outlet Flange ^{2&3}	100-600 °F	650 °F	700 °F	750 °F	800 °F	850 °F	900 °F	950 °F	1000 °F	1020 °F	1060 °F	1100 °F	1120 °F	1200 °F	1200 °F
1715	Flange	CL_150	1210	1175	1135	1065	1015	975	900	640	430	374	324	220	556		
	ButtWeld	CL_150	1500	1500	1500	1500	1500	1500	1500	1500	1500	1500	1500	1500	1500	1500	
1725	Flange	CL_150	1210	1175	1135	1065	1015	975	900	640	430	374	324	220	556		
	ButtWeld	CL_150	1500	1500	1500	1500	1500	1500	1500	1500	1500	1500	1500	1083	1500	1420	
1735	Flange	CL_150	1210	1175	1135	1065	1015	975	900	640	430	374	324	220	556		
	ButtWeld	CL_150	2500	2500	2500	2500	2500	2500	2500	2500	1830	1586	1615	1096	2500	1190	
1755	Flange	CL_150	1210	1175	1135	1065	1015	875	900	640	430	374	324	220	556		
	ButtWeld	CL_150	2500	2500	2500	2500	2500	2500	2500	2500	1912	1657	1431	972	2459	1120	
1745	Flange	CL_150	1210	1175	1135	1065	1015	975	900	640	430	374	324	220	556		
	ButtWeld	CL_150	2000	2000	2000	2000	2000	2000	2000	2000	2000	1777	1535	1042	2000	1090	2000
1765	Flange	CL_150	1015	1015	1015	1015	1015	975	900	640	430	374	324	220	556		
	ButtWeld	CL_150	1015	1015	1015	1015	1015	1015	1015	1015	1015	1015	1015	974	1015		
4" - 1775Q	Flange	CL_150	1210	1175	1135	1065	1015	975	900	640	430	374	324	220	556		
	ButtWeld	CL_150	1285	1285	1285	1285	1285	1285	1285	1285	1285	1244	1075	730	1285	830	1020
6" - 1775Q	Flange	CL_150	1210	1175	1135	1065	1015	975	900	640	430	374	324	220	556		
	ButtWeld	CL_150	1500	1500	1500	1500	1500	1500	1500	1500	1207	1046	905	614	1500	1230	1500
1785	Flange	CL_150	900	900	900	900	900	900	900	640	430	374	324	220	556		
	ButtWeld	CL_150	900	900	900	900	900	900	900	900	900	900	900	611	900		
1705R	Flange	CL_150	900	900	900	900	900	900	900	640	430	374	324	220	556		
	ButtWeld	CL_150	900	900	900	900	900	900	900	900	900	900	900	611	900	860	900
1705RR	Flange	CL_150	900	900	900	900	900	900	900	640	430	374	324	220	556		
	ButtWeld	CL_150	900	900	900	900	900	900	900	900	900	900	900	611	900	720	840

Notes:

1. Applies to 1-1/2" through 3" sizes only.
2. Consult the factory. Set pressure limits for buttweld valves can be further limited by buttweld dimensions.
3. Available CL_300 with same Pressure/Temperature rating.

Pressure/Temperature (USCS) (Contd.)

Set pressure limits (psig) for 1700 flanged & buttweld safety valves at designated temperature (°F)

Meets ASME B&PVC Section I and ASME B16.34

900 Pressure Class

Temperature Class			B	B	B	B	D	D	D	D	D	E	F	G	H	J	
Base Material Flanged			WC6	WC6	WC6	WC6	WC6	WC6	WC6	WC6	WC6	WC9	WC9	CF8M	-	-	
Base Material ButtWeld			WCC	WCC	WCC	WCC	WC6	WC6	WC6	WC6	WC6	WC9	WC9	CF8M	WC9	WC9	
Inlet Neck Material			A105	A105	A105	A105	F11	F11	F11	F11	F11	F22	F22	F316	F91	F92	
Buttweld ^{1&2}																	
Valve Type	Inlet CL_900	Outlet Flange ^{2&3}	100-600 °F	650 °F	700 °F	750 °F	800 °F	850 °F	900 °F	950 °F	1000 °F	1020 °F	1060 °F	1100 °F	1120 °F	1200 °F	1200 °F
1716	Flange	CL_150	1500	1500	1500	1500	1500	1460	1350	955	650	562	486	330	833		
	ButtWeld	CL_150	1500	1500	1500	1500	1500	1500	1500	1500	1500	1500	1500	1500	1500	1500	1500
1726	Flange	CL_150	1500	1500	1500	1500	1500	1460	1350	955	650	562	486	330	833		
	ButtWeld	CL_150	1500	1500	1500	1500	1500	1500	1500	1500	1500	1500	1500	1290	1500	1420	
1736	Flange	CL_150	1815	1765	1705	1595	1525	1460	1350	955	650	562	486	330	833		
	ButtWeld	CL_150	3000	3000	3000	3000	3000	3000	3000	2699	1830	1586	1615	1096	2773	1190	
1756	Flange	CL_150	1815	1765	1705	1595	1525	1460	1350	955	650	562	486	330	833		
	ButtWeld	CL_150	3000	3000	3000	3000	3000	3000	3000	2821	1912	1657	1431	972	2459	1120	
1746	Flange	CL_150	1815	1765	1705	1595	1525	1460	1350	955	650	562	486	330	833		
	ButtWeld	CL_150	2000	2000	2000	2000	2000	2000	2000	2000	2000	1777	1535	1042	2000		
1766	Flange	CL_150	1500	1500	1500	1500	1500	1460	1350	955	650	562	486	330	833		
	ButtWeld	CL_150	1500	1500	1500	1500	1500	1500	1500	1500	1500	1500	1361	924	1500	1480	
4" - 1776Q	Flange	CL_150	1285	1285	1285	1285	1285	1285	1285	955	650	562	486	330	833		
	ButtWeld	CL_150	1285	1285	1285	1285	1285	1285	1285	1285	1285	1244	1075	730	1285	810	1020
6" - 1776Q	Flange	CL_150	1500	1500	1500	1500	1500	1460	1350	955	650	562	486	330	833		
	ButtWeld	CL_150	1500	1500	1500	1500	1500	1500	1500	1500	1207	1046	905	614	1552	1190	1500
1786HXP	Flange	CL_150	1040	1040	1040	1040	1040	1040	1040	955	650	562	486	330	833		
	ButtWeld	CL_150	1040	1040	1040	1040	1040	1040	1040	1040	1040	1040	900	611	1040	970	1040
1706RHXP	Flange	CL_150	1010	1010	1010	1010	1010	1010	1010	955	650	562	486	330	833		
	ButtWeld	CL_150	1010	1010	1010	1010	1010	1010	1010	1010	900	900	900	611	1010	880	1010
1706RRHXP	Flange	CL_150	1010	1010	1010	1010	1010	1010	1010	955	650	562	486	330	833		
	ButtWeld	CL_150	1010	1010	1010	1010	1010	1010	1010	1010	1010	900	900	611	1010	740	1010

Notes:

1. Applies to 1-1/2" through 3" sizes only.
2. Consult the factory. Set pressure limits for buttweld valves can be further limited by buttweld dimensions.
3. Available CL_300 with same Pressure/Temperature rating.

Pressure/Temperature (USCS) (Contd.)

Set pressure limits (psig) for 1700 flanged & buttweld safety valves at designated temperature (°F)

Meets ASME B&PVC Section I and ASME B16.34

1500 Pressure Class

Temperature Class			B	B	B	B	D	D	D	D	D	E	F	G	H	J	
Base Material Flanged			WC6	WC6	WC6	WC6	WC6	WC6	WC6	WC6	WC6	WC9	WC9	CF8M	-	-	
Base Material ButtWeld			WCC	WCC	WCC	WCC	WC6	WC6	WC6	WC6	WC6	WC9	WC9	CF8M	WC9	WC9	
Inlet Neck Material			A105	A105	A105	A105	F11	F11	F11	F11	F11	F22	F22	F316	F91	F92	
ButtWeld ¹																	
Valve Type	Inlet CL_1500	Outlet Flange ²	100-600 °F	650 °F	700 °F	750 °F	800 °F	850 °F	900 °F	950 °F	1000 °F	1020 °F	1060 °F	1100 °F	1120 °F	1200 °F	1200 °F
1717	Flange	CL_150	3025	2940	2840	2660	2540	2435	2245	1595	1080	936	810	550	-		
	ButtWeld	CL_150	3100	3100	3100	3100	3100	3100	3100	3100	3100	2737	2367	1603	3100	2110	
1727	Flange	CL_150	3025	2940	2840	2660	2540	2435	2245	1595	1080	936	810	550	1389		
	ButtWeld	CL_150	3100	3100	3100	3100	3100	3100	3100	3100	2540	2201	1903	1290	3100	1970	
1737	Flange	CL_150	3025	2940	2840	2660	2540	2435	2245	1595	1080	936	810	550	1389		
	ButtWeld	CL_150	3100	3100	3100	3100	3100	3100	3100	3100	2156	1869	1861	1262	3100	1560	
1757	Flange	CL_150	3025	2940	2840	2660	2540	2435	2245	1595	1080	936	810	550	1389		
	ButtWeld	CL_150	3100	3100	3100	3100	3100	3100	3100	2821	1912	1657	1845	1251	3100	1820	
1747	Flange	CL_150	2000	2000	2000	2000	2000	2000	2000	1595	1080	936	810	550	1389		
	ButtWeld	CL_150	2000	2000	2000	2000	2000	2000	2000	2000	2000	1777	1845	1251	2000		
1767	Flange	CL_150	1600	1600	1600	1600	1600	1600	1600	1595	1080	936	810	550	1389		
	ButtWeld	CL_150	1600	1600	1600	1600	1600	1600	1600	1600	1600	1576	1437	976	1600	1110	1750
1777Q	Flange	CL_150	1600	1600	1600	1600	1600	1600	1600	1595	1080	936	810	550	1389		
	ButtWeld	CL_150	1600	1600	1600	1600	1600	1600	1600	1600	1080	936	810	550	1545	800	
1787	Flange	CL_150	1600	1600	1600	1600	1600	1600	1600	1595	1200	1040	900	610	1389		
	ButtWeld	CL_150	1600	1600	1600	1600	1600	1600	1600	1600	1600 ³	1600 ³	1200 ³	950 ³	1545	930	
1707R	Flange	CL_150	1600	1600	1600	1600	1600	1600	1600	1595	1080	936	810	550	1389		
	ButtWeld	CL_150	1600	1600	1600	1600	1600	1600	1600	1600	1200	1040	900	610	1545	590	1600
											1600 ³	1600 ³	1100 ³	850 ³			
1707RR	Flange	CL_150	1600	1600	1600	1600	1600	1600	1600	1595	1080	936	810	550	1389		
	ButtWeld	CL_150	1600	1600	1600	1600	1600	1600	1600	1600	1200	1040	900	610	1545	500	1600
											1600 ³	1600 ³	925 ³	720 ³			

Notes:

1. Consult the factory. Set pressure limits for buttWeld valves can be further limited by buttWeld dimensions.
2. Available CL_300 with same Pressure/Temperature rating.
3. Meets ASME B&PVC Section I, Code Case 1876-2, but does not meet ANSI B16.34. (1996 Edition)

Pressure/Temperature (USCS) (Contd.)

Set pressure limits (psig) for 1700 flanged & buttweld safety valves at designated temperature (°F)

Meets ASME B&PVC Section I and ASME B16.34

2500 Pressure Class

Temp Class Base Mtl Flanged Base Mtl BW Inlet Neck Mtl BW ¹			B WC6 WCC A105	B WC6 WCC A105	B WC6 WCC A105	B WC6 WCC A105	D WC6 WC6 F11	D WC6 WC6 F11	D WC6 WC6 F11	D WC6 WC6 F11	D WC6 WC6 F11	D WC6 WC6 F11	E WC9 WC9 F22	F WC9 WC9 F22	G CF8M CF8M F316	H - WC9 F91	J - WC9 F92
Valve Type	Inlet CL_2500	Outlet Flange ²	100-600°F	650°F	700°F	750°F	800°F	850°F	900°F	950°F	1000°F	1020°F	1060°F	1100°F	1120°F	1200°F	1200°F
1719	Flange	CL_300	3100	3100	3100	3100	3100	3100	3100	2655	1800	1560	1347	915	2315		
	ButtWeld	CL_300	3100	3100	3100	3100	3100	3100	3100	3100	3100	2737	2429	1645	3100	2467	
1729	Flange	CL_300	3100	3100	3100	3100	3100	3100	3100	2655	1800	1560	1347	915	2315		
	ButtWeld	CL_300	3100	3100	3100	3100	3100	3100	3100	3100	2950	2557	2429	1645	3100	2455	
1739	Flange	CL_300	3100	3100	3100	3100	3100	3100	3100	2655	1800	1560	1347	915	2315		
	ButtWeld	CL_300	3100	3100	3100	3100	3100	3100	3100	3100	2600	2437	2230	1510	3100	2540	3100
												2600 ²	2600 ²	2500 ²			
1759	Flange	CL_300	3100	3100	3100	3100	3100	3100	3100	2655	1800	1560	1347	915	2315		
	ButtWeld	CL_300	3100	3100	3100	3100	3100	3100	3100	3100	2462	2134	1948	1320	3100	2550	
												2600 ²	2600 ²	2600 ²	2350 ²		
1749	Flange	CL_300	3100	3100	3100	3100	3100	3100	3100	2655	1800	1560	1347	915	2315		
	ButtWeld	CL_300	3100	3100	3100	3100	3100	3100	3100	3100	2462	2134	2154	1460	3100	2520	
												2600 ²	2600 ²	2600 ²	2150 ²		
1769	Flange	CL_300	2500	2500	2500	2500	2500	2500	2500	2500	1800	1560	1347	915	2315		
	ButtWeld	CL_300	-	-	-	-	-	-	-	-	-	-	-	-	-		

Notes:

1. Consult the factory. Set pressure limits for buttweld valves can be further limited by buttweld dimensions.
2. Meets ASME B&PVC Section I, Code Case 1876-2, but does not meet ANSI B16.34. (1996 Edition)
3. C12A, WC9, CF8M

Meets ASME B&PVC Section I and ASME B16.34

3000 Pressure Class

Temp Class Base Mtl Flanged Base Mtl BW Inlet Neck Mtl BW ¹			B WC6 WCC A105	B WC6 WCC A105	B WC6 WCC A105	B WC6 WCC A105	D WC6 WC6 F11	D WC6 WC6 F11	D WC6 WC6 F11	D WC6 WC6 F11	D WC6 WC6 F11	D WC6 WC6 F11	E WC9 WC9 F22	F WC9 WC9 F22	G CF8M CF8M F316	H - WC9 F91	J - WC9 F92
Valve Type	Inlet CL_3000	Outlet Flange ²	100-600°F	650°F	700°F	750°F	800°F	850°F	900°F	950°F	1000°F	1020°F	1060°F	1100°F	1120°F	1200°F	1200°F
1710	ButtWeld	CL_300	3100	3100	3100	3100	3100	3100	3100	3100	3100	2808	2429	1645	3100		
												3100 ²	3100 ²	2900 ²		2528	
1720	ButtWeld	CL_300	3100	3100	3100	3100	3100	3100	3100	3100	2950	2557	2429	1645	3100		
												3100 ²	3100 ²	3100 ²	3100 ²		2455
1730	ButtWeld	CL_300	3100	3100	3100	3100	3100	3100	3100	3100	2812	2437	2414	1635	3100		
												3100 ²	3100 ²	3100 ²	3100 ²		2540
1750	ButtWeld	CL_300	3100	3100	3100	3100	3100	3100	3100	3100	2462	2134	2154	1460	3100		
												3100 ²	3100 ²	3100 ²	2650 ²		2550
1740	ButtWeld	CL_300	3100	3100	3100	3100	3100	3100	3100	3100	2600	2253	2258	1529	3100		
												3100 ²	3100 ²	3100 ²	2525 ²		2520
1760	ButtWeld	CL_300	3100	3100	3100	3100	3100	3100	3100	3100	3100	2808	2429	1645	3100		
													3100 ²	3100 ²	3100 ²		2477

Notes:

1. Consult the factory. Set pressure limits for buttweld valves can be further limited by buttweld dimensions.
2. Meets ASME B&PVC Section I, Code Case 1876-2, but does not meet ANSI B16.34. (1996 Edition)

Pressure/Temperature (USCS) (Contd.)

Set pressure limits (psig) for 1700 flanged & buttweld safety valves at designated temperature (°F)

Meets ASME B&PVC Section I and ASME B16.34

4500 Pressure Class

Temperature Class			B	B	B	B	D	D	D	D	D	D	E	F	G	H	J
Base Material Flanged			WC6	WC6	WC6	WC6	WC6	WC6	WC6	WC6	WC6	WC6	WC9	WC9	CF8M	-	-
Base Material Butt weld			WCC	WCC	WCC	WCC	WC6	WC6	WC6	WC6	WC6	WC6	WC9	WC9	CF8M	WC9	WC9
Inlet Neck Material			A105	A105	A105	A105	F11	F11	F11	F11	F11	F11	F22	F22	F316	F91	F92
Valve Type	Inlet CL_4500	Outlet Flange ²	100-600 °F	650 °F	700 °F	750 °F	800 °F	850 °F	900 °F	950 °F	1000 °F	1020 °F	1060 °F	1100 °F	1120 °F	1200 °F	1200 °F
1713	ButtWeld	CL_300	5360	5360	5360	5360	5020	5020	5020	4785	3240	2808	2429	1645	4165		
										4830 ²	4830 ²	4830 ²	4750 ²	4750 ²	4750 ²	2528	5800
1723	ButtWeld	CL_300	5360	5360	5360	5360	5020	5020	5020	4785	3240	2808	2429	1645	4165		
										4830 ²	4830 ²	4830 ²	4750 ²	4750 ²	4750 ²	2455	5800
1733	ButtWeld	CL_300	5360	5360	5360	5360	5020	5020	5020	4785	3240	2808	2429	1645	4165		
										4830 ²	4830 ²	4830 ²	4750 ²	4750 ²	4750 ²	2547	5800
1753	ButtWeld	CL_300	5360	5360	5360	5360	5020	5020	5020	4785	3240	2808	2429	1645	4165		
										4830 ²	4830 ²	4830 ²	4750 ²	4750 ²	4750 ²	2554	5800
1743	ButtWeld	CL_300	5360	5360	5360	5360	5020	5020	5020	4785	3240	2808	2429	1645	4165		
										4830 ²	4830 ²	4830 ²	4750 ²	4750 ²	4750 ²	2333	5800

Notes:

1. Consult the factory. Set pressure limits for butt weld valves can be further limited by butt weld dimensions.
2. Meets ASME B&PVC Section I, Code Case 1876-2, but does not meet ANSI B16.34. (1996 Edition)

Pressure/Temperature (USCS) Alternate

Set pressure limits (psig) for 1700 flanged & buttweld safety valves at designated temperature (°F)

Meets ASME B&PVC Section I ASME B16.34 and Non-Mandatory Code ASME B31.1-Appendix II. – (Note 5)

600 Pressure Class

Temperature Class			B	B	B	B	D	D	D	D	D	E	F	G	
Base Material Flanged			WC6	WC6	WC6	WC6	WC6	WC6	WC6	WC6	WC6	WC9	WC9	CF8M	
Base Material ButtWeld			WCC	WCC	WCC	WCC	WC6	WC6	WC6	WC6	WC6	WC9	WC9	CF8M	
Inlet Neck Material			A105	A105	A105	A105	F11	F11	F11	F11	F11	F22	F22	F316	
ButtWeld ^{3&4}															
Valve Type	Inlet CL_600	Outlet Flange	100-600°F	650°F	700°F	750°F	800°F	850°F	900°F	950°F	1000°F	1020°F	1060°F	1100°F	1120°F
1715	Flange	CL_150	1210	1175	1135	1065	1015	975	806	640	430	370	280	(Note 1)	(Note 2)
		CL_300	1210	1175	1135	1065	1015	975	900	640	430	370	320	220	556
	ButtWeld	CL_150	1500	1500	1500	1477	1232	1048	806	645	477	414	280	(Note 1)	(Note 2)
		CL_300	1500	1500	1500	1500	1500	1500	1500	1500	1500	1500	1500	1500	1500
1725	Flange	CL_150	1210	1175	1048	856	743	632	517	414	306	265	(Note 1)	(Note 1)	(Note 2)
		CL_300	1210	1175	1135	1065	1015	975	900	640	430	370	320	220	556
	ButtWeld	CL_150	1393	1183	1048	856	743	632	517	414	306	265	(Note 1)	(Note 1)	(Note 2)
		CL_300	1500	1500	1500	1500	1500	1500	1500	1500	1500	1500	1500	1500	1080
1735	Flange	CL_150	1210	1175	1135	1065	1015	975	900	640	430	370	320	(Note 1)	(Note 2)
		CL_300	1210	1175	1135	1065	1015	975	900	640	430	370	320	220	556
	ButtWeld	CL_150	2500	2500	2500	2500	2439	1921	1569	1232	839	714	503	(Note 1)	(Note 2)
		CL_300	2500	2500	2500	2500	2500	2500	2500	2500	1830	1580	1615	1096	2500
1755	Flange	CL_150	1210	1175	1135	1065	1015	975	900	640	430	370	320	(Note 1)	(Note 2)
		CL_300	1210	1175	1135	1065	1015	975	900	640	430	370	320	220	556
	ButtWeld	CL_150	2274	2274	2274	1882	1569	1309	1069	790	583	506	350	(Note 1)	(Note 2)
		CL_300	2500	2500	2500	2500	2500	2500	2500	2500	1912	1664	1437	976	2469
1745	Flange	CL_150	1210	1175	1135	1065	1015	975	806	632	430	370	286	(Note 1)	(Note 2)
		CL_300	1210	1175	1135	1065	1015	975	900	640	430	370	320	220	556
	ButtWeld	CL_150	2000	2000	1736	1477	1232	1048	806	632	477	414	286	(Note 1)	(Note 2)
		CL_300	2000	2000	2000	2000	2000	2000	2000	2000	2000	1777	1535	1042	2000
1765	Flange	CL_150	1008	856	758	672	572	486	405	325	240	208	(Note 1)	(Note 1)	(Note 2)
		CL_300	1015	1015	1015	1015	1015	975	900	640	430	370	320	220	556
	ButtWeld	CL_150	1008	856	758	672	572	486	405	325	240	208	(Note 1)	(Note 1)	(Note 2)
		CL_300	1015	1015	1015	1015	1015	1015	1015	1015	1015	1015	1015	1015	924
4" - 1775Q	Flange	CL_150	1185	1027	874	743	658	549	458	366	271	235	(Note 1)	(Note 1)	(Note 2)
		CL_300	1210	1175	1135	1065	1015	975	900	640	430	370	320	220	556
	ButtWeld	CL_150	1185	1027	874	743	658	549	458	366	271	235	(Note 1)	(Note 1)	(Note 2)
		CL_300	1285	1285	1285	1285	1285	1285	1285	1285	1285	1244	1075	730	1285
6" - 1775Q	Flange	CL_150	1185	1027	874	743	658	549	458	366	271	235	(Note 1)	(Note 1)	(Note 2)
		CL_300	1210	1175	1135	1065	1015	975	900	640	430	370	320	220	556
	ButtWeld	CL_150	1185	1027	874	743	658	549	458	366	271	235	(Note 1)	(Note 1)	(Note 2)
		CL_300	1500	1500	1500	1500	1500	1500	1500	1500	1207	1046	905	614	1500
1785	Flange	CL_150	797	709	638	550	487	415	346	271	204	177	(Note 1)	(Note 1)	(Note 2)
		CL_300	900	900	900	900	900	900	900	640	430	370	320	220	556
	ButtWeld	CL_150	797	709	638	550	487	415	346	271	204	177	(Note 1)	(Note 1)	(Note 2)
		CL_300	900	900	900	900	900	900	900	900	900	900	900	611	900
1705R	Flange	CL_150	695	624	547	487	423	360	300	235	177	154	(Note 1)	(Note 1)	(Note 2)
		CL_300	900	900	900	900	900	900	900	640	430	370	320	220	556
	ButtWeld	CL_150	695	624	547	487	423	360	300	235	177	154	(Note 1)	(Note 1)	(Note 2)
		CL_300	900	900	900	900	900	900	900	900	900	900	900	611	900
1705RR	Flange	CL_150	553	490	442	390	339	294	240	192	142	123	(Note 1)	(Note 1)	(Note 2)
		CL_300	900	900	900	900	900	900	900	640	430	370	320	220	556
	ButtWeld	CL_150	553	490	442	390	339	294	240	192	142	123	(Note 1)	(Note 1)	(Note 2)
		CL_300	900	900	900	900	900	900	900	900	900	900	900	611	900

Notes:

- Not recommended at this temperature.
- Consult the factory.
- Applies to 1-1/2" through 3" sizes only.
- Consult the factory. Set pressure limits for buttweld valves can be further limited by buttweld dimensions.
- ASME B31.1 - Appendix II analysis is limited to calculating valve outlet pressure and temperature. The calculated outlet pressure and temperature, using ASME B31.1 Appendix II analysis, complies with ASME B16.34. The valve inlet pressure/temperature rating is in compliance with ASME B16.34.

Pressure/Temperature (USCS) Alternate (Contd.)

Set pressure limits (psig) for 1700 flanged & buttweld safety valves at designated temperature (°F)

Meets ASME B&PVC Section I ASME B16.34 and Non-Mandatory Code ASME B31.1-Appendix II. — (Note 5)

900 Pressure Class

Temperature Class Base Material Flanged Base Material ButtWeld Inlet Neck Material ButtWeld ^{3&4}			B WC6 WCC A105	B WC6 WCC A105	B WC6 WCC A105	B WC6 WCC A105	D WC6 WCC F11	D WC6 WCC F11	D WC6 WCC F11	D WC6 WCC F11	D WC6 WCC F11	D WC6 WCC F11	E WC9 WCC F22	F WC9 WCC F22	G CF8M CF8M F316
Valve Type	Inlet CL_900	Outlet Flange	100-600°F	650°F	700°F	750°F	800°F	850°F	900°F	950°F	1000°F	1020°F	1060°F	1100°F	1120°F
1716	Flange	CL_150	1500	1500	1500	1477	1232	1048	806	645	477	414	280	(Note 1)	(Note 2)
		CL_300	1500	1500	1500	1500	1500	1460	1350	955	650	562	486	330	833
	ButtWeld	CL_150	1500	1500	1500	1477	1232	1048	806	645	477	414	280	(Note 1)	(Note 2)
		CL_300	1500	1500	1500	1500	1500	1500	1500	1500	1500	1500	1500	1500	1500
1726	Flange	CL_150	1393	1183	1048	856	743	632	517	414	306	265	(Note 1)	(Note 1)	(Note 2)
		CL_300	1500	1500	1500	1500	1500	1460	1350	955	650	562	486	330	833
	ButtWeld	CL_150	1393	1183	1048	856	743	632	517	414	306	265	(Note 1)	(Note 1)	(Note 2)
		CL_300	1500	1500	1500	1500	1500	1500	1500	1500	1500	1500	1500	1500	1290
1736	Flange	CL_150	1815	1765	1705	1595	1525	1460	1350	955	650	562	486	(Note 1)	(Note 2)
		CL_300	1815	1765	1705	1595	1525	1460	1350	955	650	562	486	330	833
	ButtWeld	CL_150	3000	3000	3000	3000	2439	1921	1569	1232	839	714	503	(Note 1)	(Note 2)
		CL_300	3000	3000	3000	3000	3000	3000	3000	2699	1830	1586	1615	1096	2773
1756	Flange	CL_150	1815	1765	1705	1595	1525	1309	1069	790	583	506	350	(Note 1)	(Note 2)
		CL_300	1815	1765	1705	1595	1525	1460	1350	955	650	562	486	330	833
	ButtWeld	CL_150	2274	2274	2274	1882	1569	1309	1069	790	583	506	350	(Note 1)	(Note 2)
		CL_300	3000	3000	3000	3000	3000	3000	3000	2821	1912	1657	1431	972	2459
1746	Flange	CL_150	1815	1765	1705	1477	1232	1048	806	632	477	414	286	(Note 1)	(Note 2)
		CL_300	1815	1765	1705	1595	1525	1460	1350	955	650	562	486	330	833
	ButtWeld	CL_150	2000	2000	1736	1477	1232	1048	806	632	477	414	286	(Note 1)	(Note 2)
		CL_300	2000	2000	2000	2000	2000	2000	2000	2000	2000	1777	1535	1042	2000
1766	Flange	CL_150	1008	856	758	672	572	486	405	325	240	208	(Note 1)	(Note 1)	(Note 2)
		CL_300	1500	1500	1500	1500	1500	1460	1350	955	650	562	486	330	833
	ButtWeld	CL_150	1008	856	758	672	572	486	405	325	240	208	(Note 1)	(Note 1)	(Note 2)
		CL_300	1500	1500	1500	1500	1500	1500	1500	1500	1500	1500	1500	1361	924
4" -1776Q	Flange	CL_150	1185	1027	874	743	658	549	458	366	271	235	(Note 1)	(Note 1)	(Note 2)
		CL_300	1285	1285	1285	1285	1285	1285	1285	1285	955	650	562	486	330
	ButtWeld	CL_150	1185	1027	874	743	658	549	458	366	271	235	(Note 1)	(Note 1)	(Note 2)
		CL_300	1285	1285	1285	1285	1285	1285	1285	1285	1285	1244	1075	730	1285
6" -1776Q	Flange	CL_150	1185	1027	874	743	658	549	458	366	271	235	(Note 1)	(Note 1)	(Note 2)
		CL_300	1500	1500	1500	1500	1500	1460	1350	955	650	562	486	330	833
	ButtWeld	CL_150	1185	1027	874	743	658	549	458	366	271	235	(Note 1)	(Note 1)	
		CL_300	1500	1500	1500	1500	1500	1500	1500	1500	1500	1207	1046	904	614
1786XHP	Flange	CL_150	1040	1040	1040	1027	839	714	583	467	352	299	211	(Note 1)	(Note 2)
		CL_300	1040	1040	1040	1040	1040	1040	1040	955	650	562	486	330	1040
	ButtWeld	CL_150	1040	1040	1040	1027	839	714	583	467	352	299	211	(Note 1)	(Note 2)
		CL_300	1040	1040	1040	1040	1040	1040	1040	1040	1040	1040	1040	1025	611
1706RXHP	Flange	CL_150	1010	1010	1006	839	714	607	506	405	306	260	183	(Note 1)	(Note 2)
		CL_300	1010	1010	1010	1010	1010	1010	1010	955	650	562	486	330	1010
	ButtWeld	CL_150	1010	1010	1006	839	714	607	506	405	306	260	183	(Note 1)	(Note 2)
		CL_300	1010	1010	1010	1010	1010	1010	1010	1010	1010	1010	1010	900	611
1706RRXHP	Flange	CL_150	1010	1010	1006	839	714	607	506	405	306	260	183	(Note 1)	(Note 2)
		CL_300	1010	1010	1010	1010	1010	1010	1010	955	650	562	486	330	1010
	ButtWeld	CL_150	1010	1010	1006	839	714	607	506	405	306	260	183	(Note 1)	(Note 2)
		CL_300	1010	1010	1010	1010	1010	1010	1010	1010	1010	1010	1010	900	611

Notes:

- Not recommended at this temperature.
- Consult the factory.
- Applies to 1-1/2" through 3" sizes only.
- Consult the factory. Set pressure limits for buttweld valves can be further limited by buttweld dimensions.
- ASME B31.1 - Appendix II analysis is limited to calculating valve outlet pressure and temperature.
- The calculated outlet pressure and temperature, using ASME B31.1 Appendix II analysis, complies with ASME B16.34. The valve inlet pressure/temperature rating is in compliance with ASME B16.34.

Pressure/Temperature (USCS) Alternate (Contd.)

Set pressure limits (psig) for 1700 flanged & buttweld safety valves at designated temperature (°F)

Meets ASME B&PVC Section I ASME B16.34 and Non-Mandatory Code ASME B31.1-Appendix II. – (Note 4)

1500 Pressure Class

Temperature Class			B	B	B	B	D	D	D	D	D	E	F	G	
Base Material Flanged			WC6	WC6	WC6	WC6	WC6	WC6	WC6	WC6	WC6	WC9	WC9	WC9	
Base Material ButtWeld			WCC	WCC	WCC	WCC	WC6	WC6	WC6	WC6	WC6	WC9	WC9	WC9	
Inlet Neck Material			A105	A105	A105	A105	F11	F11	F11	F11	F11	F22	F22	F22	
ButtWeld ^{3&4}			A105	A105	A105	A105	F11	F11	F11	F11	F11	F11	F22	F22	
Valve Type	Inlet CL_1500	Outlet Flange	100-600°F	650°F	700°F	750°F	800°F	850°F	900°F	950°F	1000°F	1020°F	1060°F	1100°F	1120°F
1717	Flange	CL_150	2202	2202	1808	1477	1232	1048	806	645	477	414	280	(Note 1)	(Note 2)
		CL_300	3025	2940	2840	2660	2540	2435	2245	1595	1080	936	810	550	1389
	ButtWeld	CL_150	2200	2200	1808	1477	1232	1048	806	645	477	414	280	(Note 1)	(Note 2)
		CL_300	3100	3100	3100	3100	3100	3100	3100	3100	3100	3100	2737	2367	1603
1727	Flange	CL_150	1393	1183	1048	856	743	632	517	414	306	265	(Note 1)	(Note 1)	(Note 2)
		CL_300	3025	2940	2840	2660	2540	2435	2245	1595	1080	936	810	550	1389
	ButtWeld	CL_150	1393	1183	1048	856	743	632	517	414	306	265	(Note 1)	(Note 1)	(Note 2)
		CL_300	3100	3100	3100	3100	3100	3100	3100	3100	3100	2540	2201	1903	1290
1737	Flange	CL_150	3025	2940	2840	2660	2439	1921	1569	1232	839	714	503	(Note 1)	(Note 2)
		CL_300	3025	2940	2840	2660	2540	2435	2245	1595	1080	936	810	550	1389
	ButtWeld	CL_150	3000	3000	3000	3000	2439	1921	1569	1232	839	714	503	(Note 1)	(Note 2)
		CL_300	3100	3100	3100	3100	3100	3100	3100	3100	2156	1869	1861	1262	3100
1757	Flange	CL_150	2274	2274	2274	1882	1569	1309	1069	790	583	506	350	(Note 1)	(Note 2)
		CL_300	3025	2940	2840	2660	2540	2435	2245	1595	1080	936	810	550	1389
	ButtWeld	CL_150	2274	2274	2274	1882	1569	1309	1069	790	583	506	350	(Note 1)	(Note 2)
		CL_300	3100	3100	3100	3100	3100	3100	3100	2821	1912	1657	1845	1251	3100
1747	Flange	CL_150	2000	2000	1736	1477	1232	1048	806	632	477	414	286	(Note 1)	(Note 2)
		CL_300	2000	2000	2000	2000	2000	2000	2000	1595	1080	936	810	550	1389
	ButtWeld	CL_150	2200	2200	1736	1477	1232	1048	806	632	477	414	286	(Note 1)	(Note 2)
		CL_300	2000	2000	2000	2000	2000	2000	2000	2000	2000	1777	1845	1251	2000
1767	Flange	CL_150	1008	856	758	672	572	486	405	325	240	208	(Note 1)	(Note 1)	(Note 2)
		CL_300	1600	1600	1600	1600	1600	1600	1600	1600	1595	1080	936	810	550
	ButtWeld	CL_150	1008	856	758	672	572	486	405	325	240	208	(Note 1)	(Note 1)	(Note 2)
		CL_300	1600	1600	1600	1600	1600	1600	1600	1600	1600	1600	1576	1437	976
1777Q	Flange	CL_150	1185	1027	874	743	658	549	458	366	271	235	(Note 1)	(Note 1)	(Note 2)
		CL_300	1600	1600	1600	1600	1600	1600	1600	1600	1595	1080	936	810	550
	ButtWeld	CL_150	1185	1027	874	743	658	549	458	366	271	235	(Note 1)	(Note 1)	(Note 2)
		CL_300	1600	1600	1600	1600	1600	1600	1600	1600	1600	1201	1041	900	611
1787	Flange	CL_150	1528	1390	1183	1027	839	714	583	467	352	299	211	(Note 1)	(Note 2)
		CL_300	1600	1600	1600	1600	1600	1600	1600	1595	1080	936	810	550	1389
	ButtWeld	CL_150	1500	1390	1183	1027	839	714	583	467	352	299	211	(Note 1)	(Note 2)
		CL_300	1600	1600	1600	1600	1600	1600	1600	1600	1201	1041	900	611	1545
1707R	Flange	CL_150	1338	1159	1006	839	714	607	506	405	306	260	183	(Note 1)	(Note 2)
		CL_300	1600	1600	1600	1600	1600	1600	1600	1595	1080	936	810	550	1389
	ButtWeld	CL_150	1338	1159	1006	839	714	607	506	405	306	260	183	(Note 1)	(Note 2)
		CL_300	1600	1600	1600	1600	1600	1600	1600	1600	1201	1041	900	611	1545
1707RR	Flange	CL_150	1029	868	758	672	583	496	405	325	245	212	(Note 1)	(Note 1)	(Note 2)
		CL_300	1600	1600	1600	1600	1600	1600	1600	1595	1080	936	810	550	1389
	ButtWeld	CL_150	1029	868	758	672	583	496	405	325	245	212	(Note 1)	(Note 1)	(Note 2)
		CL_300	1600	1600	1600	1600	1600	1600	1600	1600	1201	1041	900	611	1545

Notes:

- Not recommended at this temperature.
- Consult the factory.
- Consult the factory. Set pressure limits for buttweld valves can be further limited by buttweld dimensions.
- ASME B31.1 - Appendix II analysis is limited to calculating valve outlet pressure and temperature. The calculated outlet pressure and temperature, using ASME B31.1 Appendix II analysis, complies with ASME B16.34. The valve inlet pressure/temperature rating is in compliance with ASME B16.34.

Pressure/Temperature (USCS) Alternate (Contd.)

Set pressure limits (psig) for 1700 flanged & buttweld safety valves at designated temperature (°F)

Meets ASME B&PVC Section I ASME B16.34 and Non-Mandatory Code ASME B31.1-Appendix II. – (Note 4)

2500 Pressure Class

Temperature Class			B	B	B	B	D	D	D	D	D	D	E	F	G
Base Material Flanged			WC6	WC6	WC6	WC6	WC6	WC6	WC6	WC6	WC6	WC6	WC9	WC9	CF8M
Base Material ButtWeld			WCC	WCC	WCC	WCC	WC6	WC6	WC6	WC6	WC6	WC6	WC9	WC9	CF8M
Inlet Neck Material			A105	A105	A105	A105	F11	F11	F11	F11	F11	F11	F22	F22	F316
ButtWeld ^{3&4}															
Valve Type	Inlet CL_2500	Outlet Flange	100-600°F	650°F	700°F	750°F	800°F	850°F	900°F	950°F	1000°F	1020°F	1060°F	1100°F	1120°F
1719	Flange	CL_300	3100	3100	3100	3100	3100	3100	3100	2655	1800	1560	1347	915	2315
	ButtWeld	CL_300	3100	3100	3100	3100	3100	3100	3100	3100	1860	1574	1517	945	2525
1729	Flange	CL_300	3100	3100	3100	3100	3100	3100	3100	2655	1800	1560	1347	915	2315
	ButtWeld	CL_300	3100	3100	3100	3100	3100	3100	3100	3100	2950	2557	2429	1645	3100
1739	Flange	CL_300	3100	3100	3100	3100	3100	3100	3100	2655	1800	1560	1347	915	2315
	ButtWeld	CL_300	3100	3100	3100	3100	3100	3100	3100	3100	2600	2600	2230	1511	3100
1759	Flange	CL_300	3100	3100	3100	3100	3100	3100	3100	2655	1800	1560	1347	915	2315
	ButtWeld	CL_300	3100	3100	3100	3100	3100	3100	3100	3100	2462	2134	2051	1390	3100
1749	Flange	CL_300	3100	3100	3100	3100	3100	3100	3100	2655	1800	1560	1347	915	2315
	ButtWeld	CL_300	3100	3100	3100	3100	3100	3100	3100	3100	2462	2134	2154	1460	3100
1769	Flange	CL_300	2500	2500	2500	2500	2500	2500	2500	2500	1800	1560	1347	915	2315
	ButtWeld	CL_300	-	-	-	-	-	-	-	-	-	-	-	-	-

Meets ASME B&PVC Section I ASME B16.34 and Non-Mandatory Code ASME B31.1-Appendix II. – (Note 4)

3000 Pressure Class

Temperature Class			B	B	B	B	D	D	D	D	D	D	E	F	G
Base Material Flanged			WC6	WC6	WC6	WC6	WC6	WC6	WC6	WC6	WC6	WC6	WC9	WC9	CF8M
Base Material ButtWeld			WCC	WCC	WCC	WCC	WC6	WC6	WC6	WC6	WC6	WC6	WC9	WC9	CF8M
Inlet Neck Material			A105	A105	A105	A105	F11	F11	F11	F11	F11	F11	F22	F22	F316
ButtWeld ^{3&4}															
Valve Type	Inlet CL_2500	Outlet Flange	100-600°F	650°F	700°F	750°F	800°F	850°F	900°F	950°F	1000°F	1020°F	1060°F	1100°F	1120°F
1710	ButtWeld	CL_300	3100	3100	3100	3100	3100	3100	3100	3100	3100	2808	2429	1645	3100
1720	ButtWeld	CL_300	3100	3100	3100	3100	3100	3100	3100	3100	2950	2557	2429	1645	3100
1730	ButtWeld	CL_300	3100	3100	3100	3100	3100	3100	3100	3100	2812	2437	2414	1635	3100
1750	ButtWeld	CL_300	3100	3100	3100	3100	3100	3100	3100	3100	2462	2134	2154	1460	3100
1740	ButtWeld	CL_300	3100	3100	3100	3100	3100	3100	3100	3100	2600	2253	2258	1529	3100
1770	ButtWeld	CL_300	3100	3100	3100	3100	3100	3100	3100	3100	3100	2808	2429	1645	3100

- Notes:
1. Not recommended at this temperature.
 2. Consult the factory.
 3. Consult the factory. Set pressure limits for buttweld valves can be further limited by buttweld dimensions.
 4. ASME B31.1 - Appendix II analysis is limited to calculating valve outlet pressure and temperature. The calculated outlet pressure and temperature, using ASME B31.1 Appendix II analysis, complies with ASME B16.34. The valve inlet pressure/temperature rating is in compliance with ASME B16.34.

Pressure/Temperature (USCS) Alternate (Contd.)

Set pressure limits (psig) for 1700 flanged & buttweld safety valves at designated temperature (°F)

Meets ASME B&PVC Section I ASME B16.34 and Non-Mandatory Code ASME B31.1-Appendix II. – (Note 2)

4500 Pressure Class

Temperature Class Base Material Flanged Base Material Butt weld Inlet Neck Material Butt weld ^{1&2}			B WC6 WCC A105	B WC6 WCC A105	B WC6 WCC A105	B WC6 WCC A105	D WC6 F11	D WC6 F11	D WC6 F11	D WC6 F11	D WC6 F11	D WC6 F11	E WC9 F22	F WC9 F22	G CF8M F316
Valve Type	Inlet CL_4500	Outlet Flange	100- 600°F	650°F	700°F	750°F	800°F	850°F	900°F	950°F	1000°F	1020°F	1060°F	1100°F	1120°F
1713	ButtWeld	CL_300	5360	5360	5360	5360	5360	5020	5020	4785	3240	2808	2429	1645	4165
1723	ButtWeld	CL_300	5360	5360	5360	5360	5360	5020	5020	4785	3240	2808	2429	1645	4165
1733	ButtWeld	CL_300	5360	5360	5360	5360	5360	5020	5020	4785	3240	2808	2429	1645	4165
1753	ButtWeld	CL_300	5360	5360	5360	5360	5360	5020	5020	4785	3240	2808	2429	1645	4165
1743	ButtWeld	CL_300	5360	5360	5360	5360	5360	5020	5020	4785	3240	2808	2429	1645	4165

Notes:

1. Consult the factory. Set pressure limits for butt weld valves can be further limited by butt weld dimensions.
2. ASME B31.1 - Appendix II analysis is limited to calculating valve outlet pressure and temperature. The calculated outlet pressure and temperature, using ASME B31.1 Appendix II analysis, complies with ASME B16.34.

Orifice Capacities

ASME, B & PVC, Section I rating - 2001 Edition pounds per hour saturated steam at 3% overpressure, 90% of actual capacity

W=51.5KAP for "P" less than or equal to 1580 psia

K=.878 (4" Q — K = .792)

W=51.5KAP x [.1906P-1000/.2292P-1061] for "P" greater than 1580 psia

A= flow area in sq. in.

P= (1.03 x set pressure) + 14.7

Apply correction factor for capacities on superheated steam. Correction factor tables begin on page 66. Review pressure temperature limits.

Pressure/temperature tables begin on page 32. The 1700 is certified as a restricted lift valve and capacities can be restricted down to 30% of its full rated capacity.

Orifice Designation & Area - Square Inches

Orifice Designation Orifice Area Sq. In. Set Pressure (psig)	1 0.994	2 1.431	3 2.545	5 3.341	4 3.976	6 7.07	Q 4"=12.25 6"=11.05	8 14.18	R 16	RR 19.29
100	5290	7615	13544	17780	21160	37626	58808	75466	85152	102662
105	5521	7949	14137	18558	22086	39273	61381	78768	88878	107154
110	5753	8282	14729	19336	23012	40919	63954	82070	92604	111646
115	5984	8615	15322	20114	23938	42565	66528	85372	96330	116138
120	6215	8948	15915	20892	24863	44212	69101	88674	100056	120630
125	6447	9282	16507	21670	25789	45858	71674	91976	103782	125122
130	6678	9615	17100	22449	26715	47505	74247	95278	107507	129614
135	6910	9948	17693	23227	27641	49151	76820	98580	111233	134106
140	7141	10281	18285	24005	28567	50797	79394	101883	114959	138598
145	7373	10614	18878	24783	29493	52444	81967	105185	118685	143090
150	7604	10948	19471	25561	30419	54090	84540	108487	122411	147582
155	7836	11281	20063	26339	31345	55736	87113	111789	126137	152074
160	8067	11614	20656	27117	32271	57383	89686	115091	129863	156566
165	8299	11947	21249	27895	33196	59029	92259	118393	133589	161058
170	8530	12281	21841	28673	34122	60676	94833	121695	137314	165550
175	8762	12614	22434	29451	35048	62322	97406	124997	141040	170042
180	8993	12947	23026	30229	35974	63968	99979	128299	144766	174534
185	9225	13280	23619	31007	36900	65615	102552	131601	148492	179026
190	9456	13614	24212	31785	37826	67261	105125	134903	152218	183518
195	9688	13947	24804	32563	38752	68907	107699	138205	155944	188010
200	9919	14280	25397	33341	39678	70554	110272	141507	159670	192502
205	10150	14613	25990	34119	40603	72200	112845	144809	163396	196994
210	10382	14946	26582	34897	41529	73847	115418	148111	167122	201486
215	10613	15280	27175	35675	42455	75493	117991	151413	170847	205978
220	10845	15613	27768	36453	43381	77139	120565	154716	174573	210470
225	11076	15946	28360	37231	44307	78786	123138	158018	178299	214962
230	11308	16279	28953	38009	45233	80432	125711	161320	182025	219454
235	11539	16613	29546	38787	46159	82078	128284	164622	185751	223946
240	11771	16946	30138	39565	47085	83725	130857	167924	189477	228438
245	12002	17279	30731	40343	48010	85371	133430	171226	193203	232930
250	12234	17612	31324	41121	48936	87018	136004	174528	196929	237422
255	12465	17946	31916	41899	49862	88664	138577	177830	200654	241914
260	12697	18279	32509	42677	50788	90310	141150	181132	204380	246406
265	12928	18612	33101	43455	51714	91957	143723	184434	208106	250898
270	13160	18945	33694	44233	52640	93603	146296	187736	211832	255390
275	13391	19279	34287	45011	53566	95249	148870	191038	215558	259882
280	13623	19612	34879	45789	54492	96896	151443	194340	219284	264374
285	13854	19945	35472	46567	55418	98542	154016	197642	223010	268866
290	14085	20278	36065	47345	56343	100189	156589	200944	226736	273358
295	14317	20611	36657	48123	57269	101835	159162	204246	230462	277850
300	14548	20945	37250	48901	58195	103481	161736	207549	234187	282342
305	14780	21278	37843	49679	59121	105128	164309	210851	237913	286834
310	15011	21611	38435	50457	60047	106774	166882	214153	241639	291326
315	15243	21944	39028	51235	60973	108420	169455	217455	245365	295818
320	15474	22278	39621	52013	61899	110067	172028	220757	249091	300310
325	15706	22611	40213	52791	62825	111713	174601	224059	252817	304802
330	15937	22944	40806	53569	63750	113360	177175	227361	256543	309294
335	16169	23277	41399	54347	64676	115006	179748	230663	260269	313786
340	16400	23611	41991	55125	65602	116652	182321	233965	263994	318278
345	16632	23944	42584	55903	66528	118299	184894	237267	267720	322770

Orifice Capacities (Contd.)

ASME, B & PVC, Section I rating - 2001 Edition pounds per hour saturated steam at 3% overpressure, 90% of actual capacity

W=51.5KAP for "P" less than or equal to 1580 psia

W=51.5KAP x [.1906P-1000/.2292P-1061] for "P" greater than 1580 psia

K=.878 (4" Q — K = .792)

A= flow area in sq. in.

P= (1.03 x set pressure) + 14.7

Apply correction factor for capacities on superheated steam. Correction factor tables begin on page 66. Review pressure temperature limits. Pressure temperature tables begin on page 32. The 1700 is certified as a restricted lift valve and capacities can be restricted down to 30% of its full rated capacity.

Orifice Designation & Area – Square Inches

Orifice Designation Orifice Area Sq. In. Set Pressure (psig)	1 0.994	2 1.431	3 2.545	5 3.341	4 3.976	6 7.07	Q 4"=12.25 6"=11.05	8 14.18	R 16	RR 19.29
350	16863	24277	43176	56681	67454	119945	187467	240569	271446	327262
355	17095	24610	43769	57459	68380	121591	190041	243871	275172	331754
360	17326	24943	44362	58237	69306	123238	192614	247173	278898	336246
365	17558	25277	44954	59015	70232	124884	195187	250475	282624	340738
370	17789	25610	45547	59793	71158	126531	197760	253777	286350	345230
375	18020	25943	46140	60571	72083	128177	200333	257079	290076	349722
380	18252	26276	46732	61349	73009	129823	202906	260382	293801	354215
385	18483	26610	47325	62127	73935	131470	205480	263684	297527	358707
390	18715	26943	47918	62905	74861	133116	208053	266986	301253	363199
395	18946	27276	48510	63683	75787	134762	210626	270288	304979	367691
400	19178	27609	49103	64461	76713	136409	213199	273590	308705	372183
405	19409	27943	49696	65239	77639	138055	215772	276892	312431	376675
410	19641	28276	50288	66017	78565	139701	218346	280194	316157	381167
415	19872	28609	50881	66795	79490	141348	220919	283496	319883	385659
420	20104	28942	51474	67573	80416	142994	223492	286798	323609	390151
425	20335	29276	52066	68351	81342	144641	226065	290100	327334	394643
430	20567	29609	52659	69129	82268	146287	228638	293402	331060	399135
435	20798	29942	53252	69907	83194	147933	231212	296704	334786	403627
440	21030	30275	53844	70685	84120	149580	233785	300006	338512	408119
445	21261	30608	54437	71463	85046	151226	236358	303308	342238	412611
450	21493	30942	55029	72241	85972	152872	238931	306610	345964	417103
455	21724	31275	55622	73019	86898	154519	241504	309912	349690	421595
460	21955	31608	56215	73797	87823	156165	244077	313214	353416	426087
465	22187	31941	56807	74575	88749	157812	246651	316517	357141	430579
470	22418	32275	57400	75353	89675	159458	249224	319819	360867	435071
475	22650	32608	57993	76131	90601	161104	251797	323121	364593	439563
480	22881	32941	58585	76909	91527	162751	254370	326423	368319	444055
485	23113	33274	59178	77687	92453	164397	256943	329725	372045	448547
490	23344	33608	59771	78465	93379	166043	259517	333027	375771	453039
495	23576	33941	60363	79243	94305	167690	262090	336329	379497	457531
500	23807	34274	60956	80021	95230	169336	264663	339631	383223	462023
505	24039	34607	61549	80799	96156	170983	267236	342933	386948	466515
510	24270	34940	62141	81577	97082	172629	269809	346235	390674	471007
515	24502	35274	62734	82355	98008	174275	272383	349537	394400	475499
520	24733	35607	63327	83133	98934	175922	274956	352839	398126	479991
525	24965	35940	63919	83911	99860	177568	277529	356141	401852	484483
530	25196	36273	64512	84689	100786	179214	280102	359443	405578	488975
535	25428	36607	65104	85467	101712	180861	282675	362745	409304	493467
540	25659	36940	65697	86245	102637	182507	285248	366047	413030	497959
545	25890	37273	66290	87023	103563	184154	287822	369350	416756	502451
550	26122	37606	66882	87801	104489	185800	290395	372652	420481	506943
555	26353	37940	67475	88579	105415	187446	292968	375954	424207	511435
560	26585	38273	68068	89357	106341	189093	295541	379256	427933	515927
565	26816	38606	68660	90135	107267	190739	298114	382558	431659	520419
570	27048	38939	69253	90913	108193	192385	300688	385860	435385	524911
575	27279	39273	69846	91691	109119	194032	303261	389162	439111	529403
580	27511	39606	70438	92469	110045	195678	305834	392464	442837	533895
585	27742	39939	71031	93247	110970	197325	308407	395766	446563	538387
590	27974	40272	71624	94025	111896	198971	310980	399068	450288	542879
595	28205	40605	72216	94803	112822	200617	313554	402370	454014	547371

Orifice Capacities (Contd.)

ASME, B & PVC, Section I rating - 2001 Edition pounds per hour saturated steam at 3% overpressure, 90% of actual capacity

W=51.5KAP for "P" less than or equal to 1580 psia

$K=.878 (4" Q - K = .792)$

W=51.5KAP x [.1906P-1000/.2292P-1061] for "P" greater than 1580 psia

A= flow area in sq. in.

P= (1.03 x set pressure) + 14.7

Apply correction factor for capacities on superheated steam. Correction factor tables begin on page 66. Review pressure temperature limits. Pressure temperature tables begin on page 32. The 1700 is certified as a restricted lift valve and capacities can be restricted down to 30% of its full rated capacity.

Orifice Designation & Area – Square Inches

Orifice Designation Orifice Area Sq. In. Set Pressure (psig)	1 0.994	2 1.431	3 2.545	5 3.341	4 3.976	6 7.07	Q 4"=12.25 6"=11.05	8 14.18	R 16	RR 19.29
600	28437	40939	72809	95581	113748	202264	316127	405672	457740	551863
605	28668	41272	73402	96359	114674	203910	318700	408974	461466	556355
610	28900	41605	73994	97138	115600	205556	321273	412276	465192	560847
615	29131	41938	74587	97916	116526	207203	323846	415578	468918	565339
620	29363	42272	75179	98694	117452	208849	326419	418880	472644	569831
625	29594	42605	75772	99472	118377	210496	328993	422183	476370	574323
630	29825	42938	76365	100250	119303	212142	331566	425485	480096	578815
635	30057	43271	76957	101028	120229	213788	334139	428787	483821	583307
640	30288	43605	77550	101806	121155	215435	336712	432089	487547	587799
645	30520	43938	78143	102584	122081	217081	339285	435391	491273	592291
650	30751	44271	78735	103362	123007	218727	341859	438693	494999	596783
655	30983	44604	79328	104140	123933	220374	344432	441995	498725	601275
660	31214	44937	79921	104918	124859	222020	347005	445297	502451	605767
665	31446	45271	80513	105696	125785	223667	349578	448599	506177	610259
670	31677	45604	81106	106474	126710	225313	352151	451901	509903	614751
675	31909	45937	81699	107252	127636	226959	354724	455203	513628	619243
680	32140	46270	82291	108030	128562	228606	357298	458505	517354	623735
685	32372	46604	82884	108808	129488	230252	359871	461807	521080	628227
690	32603	46937	83477	109586	130414	231898	362444	465109	524806	632719
695	32835	47270	84069	110364	131340	233545	365017	468411	528532	637211
700	33066	47603	84662	111142	132266	235191	367590	471713	532258	641703
705	33298	47937	85254	111920	133192	236838	370164	475016	535984	646195
710	33529	48270	85847	112698	134117	238484	372737	478318	539710	650687
715	33760	48603	86440	113476	135043	240130	375310	481620	543435	655180
720	33992	48936	87032	114254	135969	241777	377883	484922	547161	659672
725	34223	49270	87625	115032	136895	243423	380456	488224	550887	664164
730	34455	49603	88218	115810	137821	245069	383030	491526	554613	668656
735	34686	49936	88810	116588	138747	246716	385603	494828	558339	673148
740	34918	50269	89403	117366	139673	248362	388176	498130	562065	677640
745	35149	50602	89996	118144	140599	250009	390749	501432	565791	682132
750	35381	50936	90588	118922	141525	251655	393322	504734	569517	686624
755	35612	51269	91181	119700	142450	253301	395895	508036	573243	691116
760	35844	51602	91774	120478	143376	254948	398469	511338	576968	695608
765	36075	51935	92366	121256	144302	256594	401042	514640	580694	700100
770	36307	52269	92959	122034	145228	258240	403615	517942	584420	704592
775	36538	52602	93552	122812	146154	259887	406188	521244	588146	709084
780	36770	52935	94144	123590	147080	261533	408761	524546	591872	713576
785	37001	53268	94737	124368	148006	263180	411335	527849	595598	718068
790	37233	53602	95330	125146	148932	264826	413908	531151	599324	722560
795	37464	53935	95922	125924	149857	266472	416481	534453	603050	727052
800	37695	54268	96515	126702	150783	268119	419054	537755	606775	731544
805	37927	54601	97107	127480	151709	269765	421627	541057	610501	736036
810	38158	54934	97700	128258	152635	271411	424201	544359	614227	740528
815	38390	55268	98293	129036	153561	273058	426774	547661	617953	745020
820	38621	55601	98885	129814	154487	274704	429347	550963	621679	749512
825	38853	55934	99478	130592	155413	276350	431920	554265	625405	754004
830	39084	56267	100071	131370	156339	277997	434493	557567	629131	758496
835	39316	56601	100663	132148	157264	279643	437066	560869	632857	762988
840	39547	56934	101256	132926	158190	281290	439640	564171	636583	767480
845	39779	57267	101849	133704	159116	282936	442213	567473	640308	771972

Orifice Capacities (Contd.)

ASME, B & PVC, Section I rating - 2001 Edition pounds per hour saturated steam at 3% overpressure, 90% of actual capacity

W=51.5KAP for "P" less than or equal to 1580 psia

W=51.5KAP x [.1906P-1000/.2292P-1061] for "P" greater than 1580 psia

K=.878 (4" Q — K = .792)

A= flow area in sq. in.

P= (1.03 x set pressure) + 14.7

Apply correction factor for capacities on superheated steam. Correction factor tables begin on page 66. Review pressure temperature limits. Pressure temperature tables begin on page 32. The 1700 is certified as a restricted lift valve and capacities can be restricted down to 30% of its full rated capacity.

Orifice Designation & Area – Square Inches

Orifice Designation Orifice Area Sq. In. Set Pressure (psig)	1 0.994	2 1.431	3 2.545	5 3.341	4 3.976	6 7.07	Q 4"=12.25 6"=11.05	8 14.18	R 16	RR 19.29
850	40010	57600	102441	134482	160042	284582	444786	570775	644034	776464
855	40242	57934	103034	135260	160968	286229	447359	574077	647760	780956
860	40473	58267	103627	136038	161894	287875	449932	577379	651486	785448
865	40705	58600	104219	136816	162820	289521	452506	580682	655212	789940
870	40936	58933	104812	137594	163746	291168	455079	583984	658938	794432
875	41168	59267	105405	138372	164672	292814	457652	587286	662664	798924
880	41399	59600	105997	139150	165597	294461	460225	590588	666390	803416
885	41630	59933	106590	139928	166523	296107	462798	593890	670115	807908
890	41862	60266	107182	140706	167449	297753	465372	597192	673841	812400
895	42093	60599	107775	141484	168375	299400	467945	600494	677567	816892
900	42325	60933	108368	142262	169301	301046	470518	603796	681293	821384
905	42556	61266	108960	143040	170227	302692	473091	607098	685019	825876
910	42788	61599	109553	143818	171153	304339	475664	610400	688745	830368
915	43019	61932	110146	144596	172079	305985	478237	613702	692471	834860
920	43251	62266	110738	145374	173004	307632	480811	617004	696197	839352
925	43482	62599	111331	146152	173930	309278	483384	620306	699922	843844
930	43714	62932	111924	146930	174856	310924	485957	623608	703648	848336
935	43945	63265	112516	147708	175782	312571	488530	626910	707374	852828
940	44177	63599	113109	148486	176708	314217	491103	630212	711100	857320
945	44408	63932	113702	149264	177634	315863	493677	633514	714826	861812
950	44640	64265	114294	150042	178560	317510	496250	636817	718552	866304
955	44871	64598	114887	150820	179486	319156	498823	640119	722278	870796
960	45103	64931	115480	151598	180412	320803	501396	643421	726004	875288
965	45334	65265	116072	152376	181337	322449	503969	646723	729730	879780
970	45565	65598	116665	153154	182263	324095	506542	650025	733455	884272
975	45797	65931	117257	153932	183189	325742	509116	653327	737181	888764
980	46028	66264	117850	154710	184115	327388	511689	656629	740907	893256
985	46260	66598	118443	155488	185041	329034	514262	659931	744633	897748
990	46491	66931	119035	156266	185967	330681	516835	663233	748359	902240
995	46723	67264	119628	157044	186893	332327	519408	666535	752085	906732
1000	46954	67597	120221	157822	187819	333974	521982	669837	755811	911224
1005	47186	67931	120813	158600	188744	335620	524555	673139	759537	915716
1010	47417	68264	121406	159378	189670	337266	527128	676441	763262	920208
1015	47649	68597	121999	160156	190596	338913	529701	679743	766988	924700
1020	47880	68930	122591	160934	191522	340559	532274	683045	770714	929192
1025	48112	69264	123184	161712	192448	342205	534848	686347	774440	933684
1030	48343	69597	123777	162490	193374	343852	537421	689650	778166	938176
1035	48575	69930	124369	163268	194300	345498	539994	692952	781892	942668
1040	48806	70263	124962	164046	195226	347145	542567	696254	785618	947160
1045	49038	70596	125555	164824	196152	348791	545140	699556	789344	951653
1050	49269	70930	126147	165602	197077	350437	547713	702858	793070	956145
1055	49500	71263	126740	166380	198003	352084	550287	706160	796795	960637
1060	49732	71596	127332	167158	198929	353730	552860	709462	800521	965129
1065	49963	71929	127925	167936	199855	355376	555433	712764	804247	969621
1070	50195	72263	128518	168714	200781	357023	558006	716066	807973	974113
1075	50426	72596	129110	169492	201707	358669	560579	719368	811699	978605
1080	50658	72929	129703	170270	202633	360316	563153	722670	815425	983097
1085	50889	73262	130296	171049	203559	361962	565726	725972	819151	987589
1090	51121	73596	130888	171827	204484	363608	568299	729274	822877	992081
1095	51352	73929	131481	172605	205410	365255	570872	732576	826602	996573

Orifice Capacities (Contd.)

ASME, B & PVC, Section I rating - 2001 Edition pounds per hour saturated steam at 3% overpressure, 90% of actual capacity

W=51.5KAP for "P" less than or equal to 1580 psia

K=.878 (4" Q - K = .792)

W=51.5KAP x [.1906P-1000/.2292P-1061] for "P" greater than 1580 psia

A= flow area in sq. in.

P= (1.03 x set pressure) + 14.7

Apply correction factor for capacities on superheated steam. Correction factor tables begin on page 66. Review pressure temperature limits. Pressure temperature tables begin on page 32. The 1700 is certified as a restricted lift valve and capacities can be restricted down to 30% of its full rated capacity.

Orifice Designation & Area - Square Inches

Orifice Designation Orifice Area Sq. In. Set Pressure (psig)	1 0.994	2 1.431	3 2.545	5 3.341	4 3.976	6 7.07	Q 4"=12.25 6"=11.05	8 14.18	R 16	RR 19.29
1100	51584	74262	132074	173383	206336	366901	573445	735878	830328	1001065
1105	51815	74595	132666	174161	207262	368547	576019	739180	834054	1005557
1110	52047	74929	133259	174939	208188	370194	578592	742483	837780	1010049
1115	52278	75262	133852	175717	209114	371840	581165	745785	841506	1014541
1120	52510	75595	134444	176495	210040	373487	583738	749087	845232	1019033
1125	52741	75928	135037	177273	210966	375133	586311	752389	848958	1023525
1130	52972	76261	135630	178051	211891	376779	588884	755691	852684	1028017
1135	53204	76595	136222	178829	212817	378426	591458	758993	856409	1032509
1140	53435	76928	136815	179607	213743	380072	594031	762295	860135	1037001
1145	53667	77261	137408	180385	214669	381718	596604	765597	863861	1041493
1150	53898	77594	138000	181163	215595	383365	599177	768899	867587	1045985
1155	54130	77928	138593	181941	216521	385011	601750	772201	871313	1050477
1160	54361	78261	139185	182719	217447	386658	604324	775503	875039	1054969
1165	54593	78594	139778	183497	218373	388304	606897	778805	878765	1059461
1170	54824	78927	140371	184275	219299	389950	609470	782107	882491	1063953
1175	55056	79261	140963	185053	220224	391597	612043	785409	886217	1068445
1180	55287	79594	141556	185831	221150	393243	614616	788711	889942	1072937
1185	55519	79927	142149	186609	222076	394889	617190	792013	893668	1077429
1190	55750	80260	142741	187387	223002	396536	619763	795316	897394	1081921
1195	55982	80593	143334	188165	223928	398182	622336	798618	901120	1086413
1200	56213	80927	143927	188943	224854	399829	624909	801920	904846	1090905
1205	56445	81260	144519	189721	225780	401475	627482	805222	908572	1095397
1210	56676	81593	145112	190499	226706	403121	630055	808524	912298	1099889
1215	56907	81926	145705	191277	227631	404768	632629	811826	916024	1104381
1220	57139	82260	146297	192055	228557	406414	635202	815128	919749	1108873
1225	57370	82593	146890	192833	229483	408060	637775	818430	923475	1113365
1230	57602	82926	147483	193611	230409	409707	640348	821732	927201	1117857
1235	57833	83259	148075	194389	231335	411353	642921	825034	930927	1122349
1240	58065	83593	148668	195167	232261	413000	645495	828336	934653	1126841
1245	58296	83926	149260	195945	233187	414646	648068	831638	938379	1131333
1250	58528	84259	149853	196723	234113	416292	650641	834940	942105	1135825
1255	58759	84592	150446	197501	235039	417939	653214	838242	945831	1140317
1260	58991	84926	151038	198279	235964	419585	655787	841544	949557	1144809
1265	59222	85259	151631	199057	236890	421231	658360	844846	953282	1149301
1270	59454	85592	152224	199835	237816	422878	660934	848149	957008	1153793
1275	59685	85925	152816	200613	238742	424524	663507	851451	960734	1158285
1280	59917	86258	153409	201391	239668	426170	666080	854753	964460	1162777
1285	60148	86592	154002	202169	240594	427817	668653	858055	968186	1167269
1290	60380	86925	154594	202947	241520	429463	671226	861357	971912	1171761
1295	60611	87258	155187	203725	242446	431110	673800	864659	975638	1176253
1300	60842	87591	155780	204503	243371	432756	676373	867961	979364	1180745
1305	61074	87925	156372	205281	244297	434402	678946	871263	983089	1185237
1310	61305	88258	156965	206059	245223	436049	681519	874565	986815	1189729
1315	61537	88591	157558	206837	246149	437695	684092	877867	990541	1194221
1320	61768	88924	158150	207615	247075	439341	686666	881169	994267	1198713
1325	62000	89258	158743	208393	248001	440988	689239	884471	997993	1203205
1330	62231	89591	159335	209171	248927	442634	691812	887773	1001719	1207697
1335	62463	89924	159928	209949	249853	444281	694385	891075	1005445	1212189
1340	62694	90257	160521	210727	250779	445927	696958	894377	1009171	1216681
1345	62926	90590	161113	211505	251704	447573	699531	897679	1012896	1221173

Orifice Capacities (Contd.)

ASME, B & PVC, Section I rating - 2001 Edition pounds per hour saturated steam at 3% overpressure, 90% of actual capacity

W=51.5KAP for "P" less than or equal to 1580 psia

W=51.5KAP x [.1906P-1000/.2292P-1061] for "P" greater than 1580 psia

K=.878 (4" Q - K = .792)

A= flow area in sq. in.

P= (1.03 x set pressure) + 14.7

Apply correction factor for capacities on superheated steam. Correction factor tables begin on page 66. Review pressure temperature limits. Pressure temperature tables begin on page 32. The 1700 is certified as a restricted lift valve and capacities can be restricted down to 30% of its full rated capacity.

Orifice Designation & Area - Square Inches

Orifice Designation Orifice Area Sq. In. Set Pressure (psig)	1 0.994	2 1.431	3 2.545	5 3.341	4 3.976	6 7.07	Q 4"=12.25 6"=11.05	8 14.18	R 16	RR 19.29
1350	63157	90924	161706	212283	252630	449220	702105	900982	1016622	1225665
1355	63389	91257	162299	213061	253556	450866	704678	904284	1020348	1230157
1360	63620	91590	162891	213839	254482	452512	707251	907586	1024074	1234649
1365	63852	91923	163484	214617	255408	454159	709824	910888	1027800	1239141
1370	64083	92257	164077	215395	256334	455805	712397	914190	1031526	1243633
1375	64315	92590	164669	216173	257260	457452	714971	917492	1035252	1248126
1380	64546	92923	165262	216951	258186	459098	717544	920794	1038978	1252618
1385	64777	93256	165855	217729	259111	460744	720117	924096	1042704	1257110
1390	65009	93590	166447	218507	260037	462391	722690	927398	1046429	1261602
1395	65240	93923	167040	219285	260963	464037	725263	930700	1050155	1266094
1400	65472	94256	167633	220063	261889	465683	727837	934002	1053881	1270586
1405	65703	94589	168225	220841	262815	467330	730410	937304	1057607	1275078
1410	65935	94923	168818	221619	263741	468976	732983	940606	1061333	1279570
1415	66166	95256	169410	222397	264667	470623	735556	943908	1065059	1284062
1420	66398	95589	170003	223175	265593	472269	738129	947210	1068785	1288554
1425	66629	95922	170596	223953	266519	473915	740702	950512	1072511	1293046
1430	66861	96255	171188	224731	267444	475562	743276	953814	1076236	1297538
1435	67092	96589	171781	225509	268370	477208	745849	957117	1079962	1302030
1440	67324	96922	172374	226287	269296	478854	748422	960419	1083688	1306522
1445	67555	97255	172966	227065	270222	480501	750995	963721	1087414	1311014
1450	67787	97588	173559	227843	271148	482147	753568	967023	1091140	1315506
1455	68018	97922	174152	228621	272074	483794	756142	970325	1094866	1319998
1460	68250	98255	174744	229399	273000	485440	758715	973627	1098592	1324490
1465	68481	98588	175337	230177	273926	487086	761288	976929	1102318	1328982
1470	68712	98921	175930	230955	274851	488733	763861	980231	1106043	1333474
1475	68944	99255	176522	231733	275777	490379	766434	983533	1109769	1337966
1480	69175	99588	177115	232511	276703	492025	769008	986835	1113495	1342458
1485	69407	99921	177708	233289	277629	493672	771581	990137	1117221	1346950
1490	69638	100254	178300	234067	278555	495318	774154	993439	1120947	1351442
1495	69870	100587	178893	234845	279481	496965	776727	996741	1124673	1355934
1500	70101	100921	179486	235623	280407	498611	779300	1000043	1128399	1360426
1505	70333	101254	180078	236401	281333	500257	781873	1003345	1132125	1364918
1510	70564	101587	180671	237179	282258	501904	784447	1006647	1135851	1369410
1515	70796	101920	181263	237957	283184	503550	787020	1009950	1139576	1373902
1520	71027	102254	181856	238735	284110	505196	789593	1013252	1143302	1378394
1525	71279	102616	182501	239582	285117	506987	792391	1016843	1147354	1382879
1530	71531	102979	183146	240428	286125	508779	795193	1020437	1151410	1388169
1535	71783	103342	183791	241276	287134	510573	797996	1024035	1155470	1393063
1540	72035	103705	184438	242124	288143	512368	800802	1027635	1159532	1397961
1545	72288	104069	185084	242973	289154	514164	803610	1031238	1163598	1402863
1550	72541	104433	185732	243823	290165	515963	806420	1034845	1167667	1407768
1555	72794	104797	186379	244673	291177	517762	809232	1038454	1171739	1412678
1560	73047	105161	187028	245524	292190	519563	812047	1042066	1175815	1417592
1565	73300	105526	187676	246376	293203	521365	814864	1045681	1179894	1422510
1570	73554	105891	188326	247229	294218	523169	817684	1049299	1183976	1427432
1575	73808	106257	188976	248082	295233	524975	820505	1052920	1188062	1432358
1580	74062	106623	189626	248936	296249	526782	823330	1056544	1192152	1437288
1585	74316	106989	190277	249790	297266	528590	826156	1060171	1196244	1442222
1590	74571	107355	190929	250646	298284	530400	828985	1063802	1200340	1447160
1595	74825	107722	191581	251502	299303	532212	831816	1067435	1204440	1452103

Orifice Capacities (Contd.)

ASME, B & PVC, Section I rating - 2001 Edition pounds per hour saturated steam at 3% overpressure, 90% of actual capacity

W=51.5KAP for "P" less than or equal to 1580 psia

K=.878 (4" Q — K = .792)

W=51.5KAP x [.1906P-1000/.2292P-1061] for "P" greater than 1580 psia

A= flow area in sq. in.

P= (1.03 x set pressure) + 14.7

Apply correction factor for capacities on superheated steam. Correction factor tables begin on page 66. Review pressure temperature limits. Pressure temperature tables begin on page 32. The 1700 is certified as a restricted lift valve and capacities can be restricted down to 30% of its full rated capacity.

Orifice Designation & Area – Square Inches

Orifice Designation Orifice Area Sq. In. Set Pressure (psig)	1 0.994	2 1.431	3 2.545	5 3.341	4 3.976	6 7.07	Q 4"=12.25 6"=11.05	8 14.18	R 16	RR 19.29
1600	75080	108089	192233	252358	300323	534025	834650	1071071	1208543	1457050
1605	75335	108456	192877	253216	301343	535839	-	-	-	-
1610	75591	108823	193540	254074	302364	537655	-	-	-	-
1615	75846	109191	194195	254933	303387	539473	-	-	-	-
1620	76102	109560	194850	255793	304410	541292	-	-	-	-
1625	76358	109928	195505	256653	305434	543113	-	-	-	-
1630	76614	110297	196161	257515	306459	544936	-	-	-	-
1635	76871	110666	196818	258376	307484	546760	-	-	-	-
1640	77127	111036	197475	259239	308511	548585	-	-	-	-
1645	77384	111406	198133	260103	309539	550412	-	-	-	-
1650	77641	111776	198791	260967	310567	552241	-	-	-	-
1655	77899	112146	199450	261832	311597	554072	-	-	-	-
1660	78156	112517	200109	262698	312627	555904	-	-	-	-
1665	78414	112888	200769	263564	313658	557738	-	-	-	-
1670	78672	113260	201430	264432	314690	559573	-	-	-	-
1675	78930	113632	202091	265300	315723	561410	-	-	-	-
1680	79189	114004	202753	266169	316757	563249	-	-	-	-
1685	79448	114376	203416	267038	317792	565089	-	-	-	-
1690	79707	114749	204079	267909	318828	566931	-	-	-	-
1695	79966	115122	204743	268780	319865	568775	-	-	-	-
1700	80225	115496	205407	269652	320903	570621	-	-	-	-
1705	80485	115870	206072	270525	321942	572468	-	-	-	-
1710	80745	116244	206737	271399	322982	574317	-	-	-	-
1715	81005	116618	207404	272273	324023	576167	-	-	-	-
1720	81266	116993	208070	273149	325064	578020	-	-	-	-
1725	81526	117369	208738	274025	326107	579874	-	-	-	-
1730	81787	117744	209406	274902	327151	581730	-	-	-	-
1735	82049	118120	210075	275780	328196	583588	-	-	-	-
1740	82310	118497	210744	276659	329241	585447	-	-	-	-
1745	82572	118874	211414	277538	330288	587309	-	-	-	-
1750	82834	119251	212085	278419	331336	589172	-	-	-	-
1755	83096	119628	212756	279300	332385	591037	-	-	-	-
1760	83358	120006	213428	280182	333435	592903	-	-	-	-
1765	83621	120384	214101	281065	334485	594772	-	-	-	-
1770	83884	120763	214774	281949	335537	596642	-	-	-	-
1775	84147	121142	215448	282834	336590	598515	-	-	-	-
1780	84411	121521	216123	283719	337644	600389	-	-	-	-
1785	84674	121901	216798	284606	338699	602265	-	-	-	-
1790	84938	122281	217474	285493	339755	604143	-	-	-	-
1795	85203	122661	218151	286382	340812	606022	-	-	-	-
1800	85467	123042	218828	287271	341871	607904	-	-	-	-
1805	85732	123423	219506	288161	342930	609788	-	-	-	-
1810	85997	123805	220185	289052	343990	611673	-	-	-	-
1815	86263	124187	220864	289944	345052	613561	-	-	-	-
1820	86528	124569	221544	290837	346114	615450	-	-	-	-
1825	86794	124952	222225	291731	347178	617342	-	-	-	-
1830	87060	125336	222907	292625	348243	619235	-	-	-	-
1835	87327	125719	223589	293521	349309	621130	-	-	-	-
1840	87594	126103	224272	294418	350376	623028	-	-	-	-
1845	87861	126488	224956	295315	351444	624927	-	-	-	-

Orifice Capacities (Contd.)

ASME, B & PVC, Section I rating - 2001 Edition pounds per hour saturated steam at 3% overpressure, 90% of actual capacity

W=51.5KAP for "P" less than or equal to 1580 psia

W=51.5KAP x [.1906P-1000/.2292P-1061] for "P" greater than 1580 psia

K=.878 (4" Q — K = .792)

A= flow area in sq. in.

P= (1.03 x set pressure) + 14.7

Apply correction factor for capacities on superheated steam. Correction factor tables begin on page 66. Review pressure temperature limits. Pressure temperature tables begin on page 32. The 1700 is certified as a restricted lift valve and capacities can be restricted down to 30% of its full rated capacity.

Orifice Designation & Area – Square Inches

Orifice Designation Orifice Area Sq. In. Set Pressure (psig)	1 0.994	2 1.431	3 2.545	5 3.341	4 3.976	6 7.07	Q 4"=12.25 6"=11.05	8 14.18	R 16	RR 19.29
1850	88128	126872	225640	296214	352513	626828	-	-	-	-
1855	88395	127258	226325	297113	353583	628732	-	-	-	-
1860	88663	127643	227011	298014	354655	630637	-	-	-	-
1865	88932	128029	227698	298915	355728	632544	-	-	-	-
1870	89200	128416	228385	299817	356802	634454	-	-	-	-
1875	89469	128803	229073	300721	357877	636366	-	-	-	-
1880	89738	129190	229762	301625	358953	638279	-	-	-	-
1885	90007	129578	230452	302530	360030	640195	-	-	-	-
1890	90277	129966	231142	303437	361109	642113	-	-	-	-
1895	90547	130355	231833	304344	362189	644033	-	-	-	-
1900	90817	130744	232525	305252	363270	645955	-	-	-	-
1905	91088	131133	233218	306162	364352	647879	-	-	-	-
1910	91358	131523	233911	307072	365435	649806	-	-	-	-
1915	91630	131914	234606	307983	366520	651735	-	-	-	-
1920	91901	132304	235301	308896	367606	653665	-	-	-	-
1925	92173	132696	235997	309809	368693	655598	-	-	-	-
1930	92445	133087	236693	310724	369781	657534	-	-	-	-
1935	92717	133480	237391	311639	370871	659471	-	-	-	-
1940	92990	133872	238089	312556	371961	661411	-	-	-	-
1945	93263	134265	238788	313474	373054	663353	-	-	-	-
1950	93536	134659	239488	314393	374147	665297	-	-	-	-
1955	93810	135053	240188	315312	375242	667243	-	-	-	-
1960	94084	135447	240890	316233	376338	669192	-	-	-	-
1965	94358	135842	241592	317155	377435	671143	-	-	-	-
1970	94633	136237	242295	318078	378533	673097	-	-	-	-
1975	94908	136633	242999	319003	379633	675052	-	-	-	-
1980	95183	137030	243704	319928	380734	677011	-	-	-	-
1985	95459	137426	244410	320854	381837	678971	-	-	-	-
1990	95735	137824	245117	321782	382941	680934	-	-	-	-
1995	96011	138221	245824	322711	384046	682899	-	-	-	-
2000	96288	138620	246532	323640	385152	684867	-	-	-	-
2005	96565	139018	247241	324571	386260	686837	-	-	-	-
2010	96842	139418	247951	325503	387370	688809	-	-	-	-
2015	97120	139817	248662	326437	388480	690784	-	-	-	-
2020	97398	140218	249374	327371	389592	692761	-	-	-	-
2025	97676	140618	250087	328307	390706	694741	-	-	-	-
2030	97955	141020	250800	329243	391821	696724	-	-	-	-
2035	98234	141421	251515	330181	392937	698708	-	-	-	-
2040	98513	141824	252230	331121	394054	700696	-	-	-	-
2045	98793	142226	252947	332061	395174	702686	-	-	-	-
2050	99073	142630	253664	333003	396294	704678	-	-	-	-
2055	99354	143033	254382	333945	397416	706673	-	-	-	-
2060	99634	143438	255101	334889	398539	708671	-	-	-	-
2065	99916	143843	255821	335835	399664	710671	-	-	-	-
2070	100197	144248	256542	336781	400791	712674	-	-	-	-
2075	100479	144654	257264	337729	401918	714679	-	-	-	-
2080	100762	145060	257987	338678	403048	716687	-	-	-	-
2085	101044	145467	258711	339628	404179	718698	-	-	-	-
2090	101327	145875	259436	340579	405311	720712	-	-	-	-
2095	101611	146283	260161	341532	406445	722728	-	-	-	-

Orifice Capacities (Contd.)

ASME, B & PVC, Section I rating - 2001 Edition pounds per hour saturated steam at 3% overpressure, 90% of actual capacity

W=51.5KAP for "P" less than or equal to 1580 psia

K=.878 (4" Q — K = .792)

W=51.5KAP x [.1906P-1000/.2292P-1061] for "P" greater than 1580 psia

A= flow area in sq. in.

P= (1.03 x set pressure) + 14.7

Apply correction factor for capacities on superheated steam. Correction factor tables begin on page 66. Review pressure temperature limits. Pressure temperature tables begin on page 32. The 1700 is certified as a restricted lift valve and capacities can be restricted down to 30% of its full rated capacity.

Orifice Designation & Area – Square Inches

Orifice Designation Orifice Area Sq. In. Set Pressure (psig)	1 0.994	2 1.431	3 2.545	5 3.341	4 3.976	6 7.07	Q 4"=12.25 6"=11.05	8 14.18	R 16	RR 19.29
2100	101895	146692	260888	342486	407580	724747	-	-	-	-
2105	102179	147101	261616	343442	408717	726769	-	-	-	-
2110	102464	147511	262345	344398	409856	728793	-	-	-	-
2115	102749	147921	263074	345356	410996	730820	-	-	-	-
2120	103034	148332	263805	346315	412137	732850	-	-	-	-
2125	103320	148743	264537	347276	413280	734883	-	-	-	-
2130	103606	149155	265269	348238	414425	736918	-	-	-	-
2135	103893	149568	266003	349201	415572	738957	-	-	-	-
2140	104179	149981	266738	350166	416719	740998	-	-	-	-
2145	104467	150395	267474	351132	417869	743042	-	-	-	-
2150	104755	150809	268211	352099	419020	745089	-	-	-	-
2155	105043	151224	268949	353068	420173	747139	-	-	-	-
2160	105332	151639	269688	354038	421328	749192	-	-	-	-
2165	105621	152056	270428	355010	422484	751248	-	-	-	-
2170	105910	152472	271169	355983	423642	753307	-	-	-	-
2175	106200	152890	271911	356957	424801	755369	-	-	-	-
2180	106490	153308	272654	357933	425962	757434	-	-	-	-
2185	106781	153726	273399	358910	427125	759501	-	-	-	-
2190	107072	154145	274144	359888	428290	761572	-	-	-	-
2195	107364	154565	274891	360869	429456	763646	-	-	-	-
2200	107656	154985	275638	361850	430624	765723	-	-	-	-
2205	107948	155407	276387	362833	431794	767804	-	-	-	-
2210	108241	155828	277137	363818	432966	769887	-	-	-	-
2215	108534	156251	277888	364804	434139	771973	-	-	-	-
2220	108828	156673	278641	365791	435314	774063	-	-	-	-
2225	109122	157097	279394	366780	436491	776156	-	-	-	-
2230	109417	157521	280148	367771	437670	778252	-	-	-	-
2235	109712	157946	280904	368763	438851	780351	-	-	-	-
2240	110008	158372	281661	369756	440033	782454	-	-	-	-
2245	110304	158798	282419	370751	441218	784560	-	-	-	-
2250	110601	159225	283178	371748	442404	786669	-	-	-	-
2255	110898	159653	283939	372746	443592	788781	-	-	-	-
2260	111195	160081	284700	373746	444782	790897	-	-	-	-
2265	111493	160510	285463	374748	445973	793016	-	-	-	-
2270	111791	160939	286227	375751	447167	795139	-	-	-	-
2275	112090	161370	286993	376755	448363	797265	-	-	-	-
2280	112390	161801	287759	377762	449560	799395	-	-	-	-
2285	112690	162232	288527	378770	450760	801527	-	-	-	-
2290	112990	162665	289296	379779	451961	803664	-	-	-	-
2295	113291	163098	290066	380790	453165	805804	-	-	-	-
2300	113592	163532	290838	381803	454370	807947	-	-	-	-
2305	113894	163966	291611	382818	455578	810094	-	-	-	-
2310	114196	164402	292385	383834	456787	812245	-	-	-	-
2315	114499	164838	293160	384852	457998	814399	-	-	-	-
2320	114803	165274	293937	385872	459212	816557	-	-	-	-
2325	115107	165712	294715	386893	460428	818718	-	-	-	-
2330	115411	166150	295495	387917	461645	820884	-	-	-	-
2335	115716	166589	296275	388942	462865	823052	-	-	-	-
2340	116021	167029	297057	389968	464087	825225	-	-	-	-
2345	116327	167469	297841	390997	465311	827402	-	-	-	-

Orifice Capacities (Contd.)

ASME, B & PVC, Section I rating - 2001 Edition pounds per hour saturated steam at 3% overpressure, 90% of actual capacity

W=51.5KAP for "P" less than or equal to 1580 psia

W=51.5KAP x [.1906P-1000/.2292P-1061] for "P" greater than 1580 psia

K=.878 (4" Q — K = .792)

A= flow area in sq. in.

P= (1.03 x set pressure) + 14.7

Apply correction factor for capacities on superheated steam. Correction factor tables begin on page 66. Review pressure temperature limits. Pressure temperature tables begin on page 32. The 1700 is certified as a restricted lift valve and capacities can be restricted down to 30% of its full rated capacity.

Orifice Designation & Area – Square Inches

Orifice Designation Orifice Area Sq. In. Set Pressure (psig)	1 0.994	2 1.431	3 2.545	5 3.341	4 3.976	6 7.07	Q 4"=12.25 6"=11.05	8 14.18	R 16	RR 19.29
2350	116634	167911	298626	392027	466537	829582	-	-	-	-
2355	116941	168353	299412	393059	467765	831766	-	-	-	-
2360	117248	168796	300199	394093	468995	833954	-	-	-	-
2365	117557	169239	300988	395129	470228	836145	-	-	-	-
2370	117865	169684	301779	396166	471463	838341	-	-	-	-
2375	118175	170129	302570	397206	472700	840540	-	-	-	-
2380	118484	170575	303364	398247	473939	842744	-	-	-	-
2385	118795	171022	304158	399290	475180	844951	-	-	-	-
2390	119106	171469	304954	400335	476424	847163	-	-	-	-
2395	119417	171918	305752	401382	477670	849378	-	-	-	-
2400	119729	172367	306551	402431	478918	851598	-	-	-	-
2405	120042	172817	307351	403482	480169	853822	-	-	-	-
2410	120355	173268	308153	404535	481422	856050	-	-	-	-
2415	120669	173720	308957	405589	482677	858282	-	-	-	-
2420	120983	174172	309762	406646	483935	860518	-	-	-	-
2425	121298	174626	310568	407705	485194	862758	-	-	-	-
2430	121614	175080	311376	408766	486457	865003	-	-	-	-
2435	121930	175535	312186	409828	487722	867252	-	-	-	-
2440	122247	175991	312997	410893	488989	869505	-	-	-	-
2445	122564	176448	313810	411960	490258	871763	-	-	-	-
2450	122882	176906	314624	413029	491530	874025	-	-	-	-
2455	123201	177365	315440	414100	492805	876291	-	-	-	-
2460	123520	177824	316257	415173	494082	878562	-	-	-	-
2465	123840	178285	317076	416248	495362	880837	-	-	-	-
2470	124161	178746	317897	417326	496644	883117	-	-	-	-
2475	124482	179209	318719	418405	497928	885401	-	-	-	-
2480	124804	179672	319543	419487	499216	887690	-	-	-	-
2485	125126	180136	320369	420570	500505	889984	-	-	-	-
2490	125449	180601	321196	421656	501798	892282	-	-	-	-
2495	125773	181068	322025	422745	503093	894585	-	-	-	-
2500	126097	181535	322855	423835	504391	896892	-	-	-	-
2505	126422	182003	323688	424928	505691	899204	-	-	-	-
2510	126748	182472	324522	426023	506994	901522	-	-	-	-
2515	127075	182942	325358	427120	508300	903843	-	-	-	-
2520	127402	183413	326195	428220	509608	906170	-	-	-	-
2525	127730	183885	327035	429322	510920	908502	-	-	-	-
2530	128058	184357	327876	430426	512234	910839	-	-	-	-
2535	128387	184831	328719	431532	513551	913180	-	-	-	-
2540	128717	185306	329563	432641	514870	915527	-	-	-	-
2545	129048	185782	330410	433752	516193	917878	-	-	-	-
2550	129379	186259	331258	434866	517518	920235	-	-	-	-
2555	129711	186737	332109	435982	518846	922597	-	-	-	-
2560	130044	187217	332961	437101	520178	924964	-	-	-	-
2565	130378	187697	333815	438222	521512	927336	-	-	-	-
2570	130712	188178	334670	439345	522849	929714	-	-	-	-
2575	131047	188660	335528	440471	524189	932097	-	-	-	-
2780	131383	189144	336388	441600	525532	934485	-	-	-	-
2585	131719	189628	337249	442731	526878	936878	-	-	-	-
2590	132056	190114	338113	443865	528227	939277	-	-	-	-
2595	132394	190600	338978	445001	529579	941682	-	-	-	-

Orifice Capacities (Contd.)

ASME, B & PVC, Section I rating - 2001 Edition pounds per hour saturated steam at 3% overpressure, 90% of actual capacity

W=51.5KAP for "P" less than or equal to 1580 psia

$K=.878 (4" Q - K = .792)$

W=51.5KAP x [.1906P-1000/.2292P-1061] for "P" greater than 1580 psia

A= flow area in sq. in.

P= (1.03 x set pressure) + 14.7

Apply correction factor for capacities on superheated steam. Correction factor tables begin on page 66. Review pressure temperature limits. Pressure temperature tables begin on page 32. The 1700 is certified as a restricted lift valve and capacities can be restricted down to 30% of its full rated capacity.

Orifice Designation & Area – Square Inches

Orifice Designation Orifice Area Sq. In. Set Pressure (psig)	1 0.994	2 1.431	3 2.545	5 3.341	4 3.976	6 7.07	Q 4"=12.25 6"=11.05	8 14.18	R 16	RR 19.29
2600	132733	191088	339846	446140	530935	944092	-	-	-	-
2605	133073	191577	340715	447281	532293	946507	-	-	-	-
2610	133413	192067	341587	448425	533654	948928	-	-	-	-
2615	133754	192558	342461	449572	535019	951355	-	-	-	-
2620	134096	193050	343336	450722	536387	953787	-	-	-	-
2625	134439	193544	344214	451874	537758	956225	-	-	-	-
2630	134783	194039	345094	453029	539133	958669	-	-	-	-
2635	135127	194534	345975	454186	540510	961119	-	-	-	-
2640	135472	195031	346859	455347	541891	963575	-	-	-	-
2645	135819	195530	347745	456510	543276	966036	-	-	-	-
2650	136165	196029	348634	457676	544663	968504	-	-	-	-
2655	136513	196530	349524	458845	546054	970977	-	-	-	-
2660	136862	197032	350417	460017	547449	973457	-	-	-	-
2665	137211	197535	351311	461191	548847	975942	-	-	-	-
2670	137562	198039	352208	462369	550248	978434	-	-	-	-
2675	137913	198545	353108	463549	551653	980932	-	-	-	-
2680	138265	199052	354009	464733	553061	983437	-	-	-	-
2685	138618	199560	354913	465919	554473	985947	-	-	-	-
2690	138972	200069	355819	467109	555889	988464	-	-	-	-
2695	139327	200580	356727	468301	557308	990988	-	-	-	-
2700	139682	201092	357638	469497	558731	993518	-	-	-	-
2705	140039	201606	358551	470695	560157	996054	-	-	-	-
2710	140396	202120	359467	471897	561587	998598	-	-	-	-
2715	140755	202636	360384	473102	563021	1001147	-	-	-	-
2720	141114	203154	361305	474310	564459	1003704	-	-	-	-
2725	141475	203673	362227	475521	565900	1006267	-	-	-	-
2730	141836	204193	363152	476736	567346	1008837	-	-	-	-
2735	142198	204714	364080	477954	568795	1011414	-	-	-	-
2740	142562	205237	365010	479175	570248	1013998	-	-	-	-
2745	142926	205762	365943	480399	571705	1016589	-	-	-	-
2750	143291	206288	366878	481627	573166	1019187	-	-	-	-
2755	143657	206815	367816	482858	574631	1021792	-	-	-	-
2760	144025	207344	368756	484092	576100	1024404	-	-	-	-
2765	144393	207874	369699	485330	577573	1027023	-	-	-	-
2770	144762	208405	370645	486571	579051	1029650	-	-	-	-
2775	145133	208939	371593	487816	580532	1032284	-	-	-	-
2780	145504	209473	372544	489065	582018	1034926	-	-	-	-
2785	145876	210010	373497	490316	583507	1037575	-	-	-	-
2790	146250	210547	374454	491572	585002	1040232	-	-	-	-
2795	146625	211087	375413	492831	586500	1042896	-	-	-	-
2800	147000	211627	376375	494094	588003	1045568	-	-	-	-
2805	147377	212170	377339	495360	589510	1048248	-	-	-	-
2810	147755	212714	378307	496630	591021	1050936	-	-	-	-
2815	148134	213259	379277	497904	592537	1053631	-	-	-	-
2820	148514	213807	380250	499182	594058	1056335	-	-	-	-
2825	148895	214355	381227	500463	595583	1059047	-	-	-	-
2830	149278	214906	382206	501748	597112	1061767	-	-	-	-
2835	149661	215458	383188	503037	598646	1064495	-	-	-	-
2840	150046	216012	384173	504330	600185	1067231	-	-	-	-
2845	150432	216567	385161	505627	601729	1069976	-	-	-	-

Orifice Capacities (Contd.)

ASME, B & PVC, Section I rating - 2001 Edition pounds per hour saturated steam at 3% overpressure, 90% of actual capacity

W=51.5KAP for "P" less than or equal to 1580 psia

W=51.5KAP x [.1906P-1000/.2292P-1061] for "P" greater than 1580 psia

K=.878 (4" Q — K = .792)

A= flow area in sq. in.

P= (1.03 x set pressure) + 14.7

Apply correction factor for capacities on superheated steam. Correction factor tables begin on page 66. Review pressure temperature limits. Pressure temperature tables begin on page 32. The 1700 is certified as a restricted lift valve and capacities can be restricted down to 30% of its full rated capacity.

Orifice Designation & Area – Square Inches

Orifice Designation Orifice Area Sq. In. Set Pressure (psig)	1 0.994	2 1.431	3 2.545	5 3.341	4 3.976	6 7.07	Q 4"=12.25 6"=11.05	8 14.18	R 16	RR 19.29
2850	150819	217125	386152	506928	603277	1072729	-	-	-	-
2855	151207	217684	387146	508234	604830	1075490	-	-	-	-
2860	151597	218244	388143	509543	606388	1078260	-	-	-	-
2865	151987	218807	389143	510856	607951	1081039	-	-	-	-
2870	152379	219371	390147	512173	609518	1083827	-	-	-	-
2875	152772	219937	391153	513495	611091	1086623	-	-	-	-
2880	153167	220505	392163	514820	612669	1089429	-	-	-	-
2885	153562	221075	393176	516150	614251	1092243	-	-	-	-
2890	153959	221646	394193	517485	615839	1095067	-	-	-	-
2895	154358	222219	395212	518823	617432	1097899	-	-	-	-
2900	154757	222795	396235	520166	619031	1100741	-	-	-	-
2905	155158	223372	397262	521514	620634	1103593	-	-	-	-
2910	155560	223951	398292	522865	622243	1106453	-	-	-	-
2915	155964	224532	399325	524222	623857	1109324	-	-	-	-
2920	156369	225115	400361	525583	625477	1112203	-	-	-	-
2925	156775	225699	401402	526948	627102	1115093	-	-	-	-
2930	157183	226286	402445	528318	628732	1117992	-	-	-	-
2935	157592	226875	403493	529693	630368	1120902	-	-	-	-
2940	158002	227466	404543	531073	632010	1123821	-	-	-	-
2945	158414	228059	405598	532457	633657	1126750	-	-	-	-
2950	158827	228654	406656	533846	635311	1129690	-	-	-	-
2955	159242	229251	407718	535240	636970	1132640	-	-	-	-
2960	159658	229850	408784	536639	638634	1135600	-	-	-	-
2965	160076	230452	409853	538043	640305	1138571	-	-	-	-
2970	160495	231055	410926	539452	641982	1141552	-	-	-	-
2975	160916	231661	412003	540866	643664	1144545	-	-	-	-
2980	161338	232268	413084	542285	645353	1147547	-	-	-	-
2985	161762	232878	414169	543709	647048	1150561	-	-	-	-
2990	162187	233491	415258	545139	648749	1153586	-	-	-	-
2995	162614	234105	416351	546573	650457	1156622	-	-	-	-
3000	163042	234722	417448	548013	652170	1159670	-	-	-	-
3005	163472	235341	418549	549459	653891	1162728	-	-	-	-
3010	163904	235962	419654	550910	655617	1165799	-	-	-	-
3015	164337	236586	420764	552366	657350	1168880	-	-	-	-
3020	164772	237212	421877	553828	659090	1171974	-	-	-	-
3025	165209	237841	422995	555295	660836	1175079	-	-	-	-
3030	165647	238472	424117	556768	662590	1178197	-	-	-	-
3035	166087	239105	425244	558247	664349	1181326	-	-	-	-
3040	166529	239741	426375	559732	666116	1184468	-	-	-	-
3045	166972	240380	427510	561222	667890	1187622	-	-	-	-
3050	167417	241021	428650	562719	669671	1190788	-	-	-	-
3055	167864	241664	429794	564221	671459	1193967	-	-	-	-
3060	168313	242310	430943	565729	673254	1197159	-	-	-	-
3065	168764	242959	432097	567244	675056	1200364	-	-	-	-
3070	169216	243610	433255	568764	676866	1203582	-	-	-	-
3075	169670	244264	434418	570291	678683	1206813	-	-	-	-
3080	170126	244921	435586	571824	680507	1210057	-	-	-	-
3085	170584	245580	436759	573364	682339	1213315	-	-	-	-
3090	171044	246242	437936	574910	684179	1216586	-	-	-	-
3095	171506	246907	439119	576462	686026	1219871	-	-	-	-
3100	171970	247575	440306	578021	687881	1223170	-	-	-	-

Orifice Capacities (Contd.)

ASME, B & PVC, Section VIII rating - 2001 Edition pounds per hour saturated steam at 10% overpressure, 90% of actual capacity

W=51.5KAP for "P" less than or equal to 1580 psia

$K=.878 (4" Q - K = .792)$

W=51.5KAP x [.1906P-1000/.2292P-1061] for "P" greater than 1580 psia

A= flow area in sq. in.

P= (1.10 x set pressure) + 14.7

Apply correction factor for capacities on superheated steam. Correction factor tables begin on page 66. Review pressure temperature limits. Pressure temperature tables begin on page 32. The 1700 is certified as a restricted lift valve and capacities can be restricted down to 30% of its full rated capacity.

Orifice Designation & Area – Square Inches

Orifice Designation Orifice Area Sq. In. Set Pressure (psig)	1 0.994	2 1.431	3 2.545	5 3.341	4 3.976	6 7.07	Q 4"=12.25 6"=11.05	8 14.18	R 16	RR 19.29
100	5604	8068	14350	18838	22418	39864	62306	79954	90216	108767
105	5851	8424	14983	19669	23407	41622	65054	83481	94196	113565
110	6099	8780	15615	20500	24396	43381	67802	87007	98175	118362
115	6346	9136	16248	21331	25385	45139	70550	90534	102154	123159
120	6593	9492	16881	22161	26374	46897	73298	94060	106133	127957
125	6840	9848	17514	22992	27362	48655	76046	97587	110112	132754
130	7087	10204	18147	23823	28351	50414	78794	101113	114091	137551
135	7335	10559	18780	24654	29340	52172	81542	104640	118070	142348
140	7582	10915	19413	25485	30329	53930	84290	108166	122049	147146
145	7829	11271	20046	26316	31318	55688	87038	111693	126028	151943
150	8076	11627	20679	27147	32306	57447	89786	115219	130007	156740
155	8323	11983	21312	27978	33295	59205	92534	118745	133987	161538
160	8571	12339	21945	28809	34284	60963	95282	122272	137966	166335
165	8818	12695	22578	29639	35273	62722	98030	125798	141945	171132
170	9065	13051	23211	30470	36262	64480	100778	129325	145924	175929
175	9312	13406	23844	31301	37250	66238	103527	132851	149903	180727
180	9559	13762	24476	32132	38239	67996	106275	136378	153882	185524
185	9807	14118	25109	32963	39228	69755	109023	139904	157861	190321
190	10054	14474	25742	33794	40217	71513	111771	143431	161840	195119
195	10301	14830	26375	34625	41206	73271	114519	146957	165819	199916
200	10548	15186	27008	35456	42195	75029	117267	150484	169798	204713
205	10795	15542	27641	36287	43183	76788	120015	154010	173777	209511
210	11043	15898	28274	37117	44172	78546	122763	157537	177757	214308
215	11290	16254	28907	37948	45161	80304	125511	161063	181736	219105
220	11537	16609	29540	38779	46150	82062	128259	164590	185715	223902
225	11784	16965	30173	39610	47139	83821	131007	168116	189694	228700
230	12031	17321	30806	40441	48127	85579	133755	171643	193673	233497
235	12279	17677	31439	41272	49116	87337	136503	175169	197652	238294
240	12526	18033	32072	42103	50105	89095	139251	178696	201631	243092
245	12773	18389	32704	42934	51094	90854	141999	182222	205610	247889
250	13020	18745	33337	43764	52083	92612	144747	185748	209589	252686
255	13267	19101	33970	44595	53071	94370	147496	189275	213568	257484
260	13515	19456	34603	45426	54060	96129	150244	192801	217548	262281
265	13762	19812	35236	46257	55049	97887	152992	196328	221527	267078
270	14009	20168	35869	47088	56038	99645	155740	199854	225506	271875
275	14256	20524	36502	47919	57027	101403	158488	203381	229485	276673
280	14503	20880	37135	48750	58015	103162	161236	206907	233464	281470
285	14751	21236	37768	49581	59004	104920	163984	210434	237443	286267
290	14998	21592	38401	50412	59993	106678	166732	213960	241422	291065
295	15245	21948	39034	51242	60982	108436	169480	217487	245401	295862
300	15492	22303	39667	52073	61971	110195	172228	221013	249380	300659
305	15739	22659	40300	52904	62959	111953	174976	224540	253359	305457
310	15987	23015	40932	53735	63948	113711	177724	228066	257338	310254
315	16234	23371	41565	54566	64937	115469	180472	231593	261318	315051
320	16481	23727	42198	55397	65926	117228	183220	235119	265297	319848
325	16728	24083	42831	56228	66915	118986	185968	238646	269276	324646
330	16975	24439	43464	57059	67903	120744	188716	242172	273255	329443
335	17223	24795	44097	57890	68892	122502	191465	245699	277234	334240
340	17470	25151	44730	58720	69881	124261	194213	249225	281213	339038
345	17717	25506	45363	59551	70870	126019	196961	252751	285192	343835

Orifice Capacities (Contd.)

ASME, B & PVC, Section VIII rating - 2001 Edition pounds per hour saturated steam at 10% overpressure, 90% of actual capacity

W=51.5KAP for "P" less than or equal to 1580 psia

W=51.5KAP x [.1906P-1000/.2292P-1061] for "P" greater than 1580 psia

K=.878 (4" Q - K = .792)

A= flow area in sq. in.

P= (1.10 x set pressure) + 14.7

Apply correction factor for capacities on superheated steam. Correction factor tables begin on page 66. Review pressure temperature limits. Pressure temperature tables begin on page 32. The 1700 is certified as a restricted lift valve and capacities can be restricted down to 30% of its full rated capacity.

Orifice Designation & Area - Square Inches

Orifice Designation Orifice Area Sq. In. Set Pressure (psig)	1 0.994	2 1.431	3 2.545	5 3.341	4 3.976	6 7.07	Q 4"=12.25 6"=11.05	8 14.18	R 16	RR 19.29
350	17964	25862	45996	60382	71859	127777	199709	256278	289171	348632
355	18211	26218	46629	61213	72847	129536	202457	259804	293150	353429
360	18459	26574	47262	62044	73836	131294	205205	263331	297129	358227
365	18706	26930	47895	62875	74825	133052	207953	266857	301109	363024
370	18953	27286	48528	63706	75814	134810	210701	270384	305088	367821
375	19200	27642	49161	64537	76803	136569	213449	273910	309067	372619
380	19448	27998	49793	65367	77792	138327	216197	277437	313046	377416
385	19695	28353	50426	66198	78780	140085	218945	280963	317025	382213
390	19942	28709	51059	67029	79769	141843	221693	284490	321004	387011
395	20189	29065	51692	67860	80758	143602	224441	288016	324983	391808
400	20436	29421	52325	68691	81747	145360	227189	291543	328962	396605
405	20684	29777	52958	69522	82736	147118	229937	295069	332941	401402
410	20931	30133	53591	70353	83724	148876	232686	298596	336920	406200
415	21178	30489	54224	71184	84713	150635	235434	302122	340900	410997
420	21425	30845	54857	72015	85702	152393	238182	305649	344879	415794
425	21672	31201	55490	72845	86691	154151	240930	309175	348858	420592
430	21920	31556	56123	73676	87680	155909	243678	312702	352837	425389
435	22167	31912	56756	74507	88668	157668	246426	316228	356816	430186
440	22414	32268	57389	75338	89657	159426	249174	319754	360795	434984
445	22661	32624	58021	76169	90646	161184	251922	323281	364774	439781
450	22908	32980	58654	77000	91635	162943	254670	326807	368753	444578
455	23156	33336	59287	77831	92624	164701	257418	330334	372732	449375
460	23403	33692	59920	78662	93612	166459	260166	333860	376711	454173
465	23650	34048	60553	79493	94601	168217	262914	337387	380690	458970
470	23897	34403	61186	80323	95590	169976	265662	340913	384670	463767
475	24144	34759	61819	81154	96579	171734	268410	344440	388649	468565
480	24392	35115	62452	81985	97568	173492	271158	347966	392628	473362
485	24639	35471	63085	82816	98556	175250	273906	351493	396607	478159
490	24886	35827	63718	83647	99545	177009	276655	355019	400586	482957
495	25133	36183	64351	84478	100534	178767	279403	358546	404565	487754
500	25380	36539	64984	85309	101523	180525	282151	362072	408544	492551
505	25628	36895	65617	86140	102512	182283	284899	365599	412523	497348
510	25875	37250	66249	86970	103500	184042	287647	369125	416502	502146
515	26122	37606	66882	87801	104489	185800	290395	372652	420481	506943
520	26369	37962	67515	88632	105478	187558	293143	376178	424461	511740
525	26616	38318	68148	89463	106467	189316	295891	379705	428440	516538
530	26864	38674	68781	90294	107456	191075	298639	383231	432419	521335
535	27111	39030	69414	91125	108444	192833	301387	386758	436398	526132
540	27358	39386	70047	91956	109433	194591	304135	390284	440377	530930
545	27605	39742	70680	92787	110422	196350	306883	393810	444356	535727
550	27852	40098	71313	93618	111411	198108	309631	397337	448335	540524
555	28100	40453	71946	94448	112400	199866	312379	400863	452314	545321
560	28347	40809	72579	95279	113389	201624	315127	404390	456293	550119
565	28594	41165	73212	96110	114377	203383	317875	407916	460272	554916
570	28841	41521	73845	96941	115366	205141	320624	411443	464251	559713
575	29088	41877	74478	97772	116355	206899	323372	414969	468231	564511
580	29336	42233	75110	98603	117344	208657	326120	418496	472210	569308
585	29583	42589	75743	99434	118333	210416	328868	422022	476189	574105
590	29830	42945	76376	100265	119321	212174	331616	425549	480168	578902
595	30077	43300	77009	101096	120310	213932	334364	429075	484147	583700

Orifice Capacities (Contd.)

ASME, B & PVC, Section VIII rating - 2001 Edition pounds per hour saturated steam at 10% overpressure, 90% of actual capacity

W=51.5KAP for "P" less than or equal to 1580 psia

K=.878 (4" Q — K = .792)

W=51.5KAP x [.1906P-1000/.2292P-1061] for "P" greater than 1580 psia

A= flow area in sq. in.

P= (1.10 x set pressure) + 14.7

Apply correction factor for capacities on superheated steam. Correction factor tables begin on page 66. Review pressure temperature limits. Pressure temperature tables begin on page 32. The 1700 is certified as a restricted lift valve and capacities can be restricted down to 30% of its full rated capacity.

Orifice Designation & Area – Square Inches

Orifice Designation Orifice Area Sq. In. Set Pressure (psig)	1 0.994	2 1.431	3 2.545	5 3.341	4 3.976	6 7.07	Q 4"=12.25 6"=11.05	8 14.18	R 16	RR 19.29
600	30324	43656	77642	101926	121299	215690	337112	432602	488126	588497
605	30572	44012	78275	102757	122288	217449	339860	436128	492105	593294
610	30819	44368	78908	103588	123277	219207	342608	439655	496084	598092
615	31066	44724	79541	104419	124265	220965	345356	443181	500063	602889
620	31313	45080	80174	105250	125254	222723	348104	446708	504042	607686
625	31560	45436	80807	106081	126243	224482	350852	450234	508022	612484
630	31808	45792	81440	106912	127232	226240	353600	453761	512001	617281
635	32055	46147	82073	107743	128221	227998	356348	457287	515980	622078
640	32302	46503	82706	108574	129209	229757	359096	460813	519959	626875
645	32549	46859	83338	109404	130198	231515	361844	464340	523938	631673
650	32796	47215	83971	110235	131187	233273	364593	467866	527917	636470
655	33044	47571	84604	111066	132176	235031	367341	471393	531896	641267
660	33291	47927	85237	111897	133165	236790	370089	474919	535875	646065
665	33538	48283	85870	112728	134153	238548	372837	478446	539854	650862
670	33785	48639	86503	113559	135142	240306	375585	481972	543833	655659
675	34032	48995	87136	114390	136131	242064	378333	485499	547812	660457
680	34280	49350	87769	115221	137120	243823	381081	489025	551792	665254
685	34527	49706	88402	116051	138109	245581	383829	492552	555771	670051
690	34774	50062	89035	116882	139097	247339	386577	496078	559750	674848
695	35021	50418	89668	117713	140086	249097	389325	499605	563729	679646
700	35268	50774	90301	118544	141075	250856	392073	503131	567708	684443
705	35516	51130	90934	119375	142064	252614	394821	506658	571687	689240
710	35763	51486	91566	120206	143053	254372	397569	510184	575666	694038
715	36010	51842	92199	121037	144041	256130	400317	513711	579645	698835
720	36257	52197	92832	121868	145030	257889	403065	517237	583624	703632
725	36504	52553	93465	122699	146019	259647	405813	520764	587603	708430
730	36752	52909	94098	123529	147008	261405	408562	524290	591583	713227
735	36999	53265	94731	124360	147997	263164	411310	527816	595562	718024
740	37246	53621	95364	125191	148985	264922	414058	531343	599541	722821
745	37493	53977	95997	126022	149974	266680	416806	534869	603520	727619
750	37740	54333	96630	126853	150963	268438	419554	538396	607499	732416
755	37988	54689	97263	127684	151952	270197	422302	541922	611478	737213
760	38235	55044	97896	128515	152941	271955	425050	545449	615457	742011
765	38482	55400	98529	129346	153930	273713	427798	548975	619436	746808
770	38729	55756	99162	130177	154918	275471	430546	552502	623415	751605
775	38976	56112	99795	131007	155907	277230	433294	556028	627394	756402
780	39224	56468	100427	131838	156896	278988	436042	559555	631374	761200
785	39471	56824	101060	132669	157885	280746	438790	563081	635353	765997
790	39718	57180	101693	133500	158874	282504	441538	566608	639332	770794
795	39965	57536	102326	134331	159862	284263	444286	570134	643311	775592
800	40212	57892	102959	135162	160851	286021	447034	573661	647290	780389
805	40460	58247	103592	135993	161840	287779	449782	577187	651269	785186
810	40707	58603	104225	136824	162829	289537	452531	580714	655248	789984
815	40954	58959	104858	137654	163818	291296	455279	584240	659227	794781
820	41201	59315	105491	138485	164806	293054	458027	587767	663206	799578
825	41448	59671	106124	139316	165795	294812	460775	591293	667185	804375
830	41696	60027	106757	140147	166784	296571	463523	594819	671164	809173
835	41943	60383	107390	140978	167773	298329	466271	598346	675144	813970
840	42190	60739	108023	141809	168762	300087	469019	601872	679123	818767
845	42437	61094	108655	142640	169750	301845	471767	605399	683102	823565

Orifice Capacities (Contd.)

ASME, B & PVC, Section VIII rating - 2001 Edition

pounds per hour saturated steam at 10% overpressure, 90% of actual capacity

W=51.5KAP for "P" less than or equal to 1580 psia

K=.878 (4" Q – K = .792)

W=51.5KAP x [.1906P-1000]/.2292P-1061] for "P" greater than 1580 psia

A= flow area in sq. in.

P= (1.10 x set pressure) + 14.7

Apply correction factor for capacities on superheated steam. Correction factor tables begin on page 66. Review pressure temperature limits. Pressure temperature tables begin on page 32. The 1700 is certified as a restricted lift valve and capacities can be restricted down to 30% of its full rated capacity.

Orifice Designation & Area – Square Inches

Orifice Designation Orifice Area Sq. In. Set Pressure (psig)	1 0.994	2 1.431	3 2.545	5 3.341	4 3.976	6 7.07	Q 4"=12.25 6"=11.05	8 14.18	R 16	RR 19.29
850	42684	61450	109288	143471	170739	303604	474515	608925	687081	828362
855	42932	61806	109921	144302	171728	305362	477263	612452	691060	833159
860	43179	62162	110554	145132	172717	307120	480011	615978	695039	837957
865	43426	62518	111187	145963	173706	308878	482759	619505	699018	842754
870	43673	62874	111820	146794	174694	310637	485507	623031	702997	847551
875	43920	63230	112453	147625	175683	312395	488255	626558	706976	852348
880	44168	63586	113086	148456	176672	314153	491003	630084	710955	857146
885	44415	63942	113719	149287	177661	315911	493752	633611	714935	861943
890	44662	64297	114352	150118	178650	317670	496500	637137	718914	866740
895	44909	64653	114985	150949	179638	319428	499248	640664	722893	871538
900	45156	65009	115618	151780	180627	321186	501996	644190	726872	876335
905	45404	65365	116251	152610	181616	322944	504744	647717	730851	881132
910	45651	65721	116883	153441	182605	324703	507492	651243	734830	885930
915	45898	66077	117516	154272	183594	326461	510240	654770	738809	890727
920	46145	66433	118149	155103	184582	328219	512988	658296	742788	895524
925	46392	66789	118782	155934	185571	329978	515736	661822	746767	900321
930	46640	67144	119415	156765	186560	331736	518484	665349	750746	905119
935	46887	67500	120048	157596	187549	333494	521232	668875	754725	909916
940	47134	67856	120681	158427	188538	335252	523980	672402	758705	914713
945	47381	68212	121314	159257	189527	337011	526728	675928	762684	919511
950	47628	68568	121947	160088	190515	338769	529476	679455	766663	924308
955	47876	68924	122580	160919	191504	340527	532224	682981	770642	929105
960	48123	69280	123213	161750	192493	342285	534972	686508	774621	933903
965	48370	69636	123846	162581	193482	344044	537721	690034	778600	938700
970	48617	69991	124479	163412	194471	345802	540469	693561	782579	943497
975	48864	70347	125112	164243	195459	347560	543217	697087	786558	948294
980	49112	70703	125744	165074	196448	349318	545965	700614	790537	953092
985	49359	71059	126377	165905	197437	351077	548713	704140	794516	957889
990	49606	71415	127010	166735	198426	352835	551461	707667	798496	962686
995	49853	71771	127643	167566	199415	354593	554209	711193	802475	967484
1000	50100	72127	128276	168397	200403	356351	556957	714720	806454	972281
1005	50348	72483	128909	169228	201392	358110	559705	718246	810433	977078
1010	50595	72839	129542	170059	202381	359868	562453	721773	814412	981875
1015	50842	73194	130175	170890	203370	361626	565201	725299	818391	986673
1020	51089	73550	130808	171721	204359	363385	567949	728825	822370	991470
1025	51336	73906	131441	172552	205347	365143	570697	732352	826349	996267
1030	51584	74262	132074	173383	206336	366901	573445	735878	830328	1001065
1035	51831	74618	132707	174213	207325	368659	576193	739405	834307	1005862
1040	52078	74974	133340	175044	208314	370418	578941	742931	838287	1010659
1045	52325	75330	133972	175875	209303	372176	581690	746458	842266	1015457
1050	52572	75686	134605	176706	210291	373934	584438	749984	846245	1020254
1055	52820	76041	135238	177537	211280	375692	587186	753511	850224	1025051
1060	53067	76397	135871	178368	212269	377451	589934	757037	854203	1029848
1065	53314	76753	136504	179199	213258	379209	592682	760564	858182	1034646
1070	53561	77109	137137	180030	214247	380967	595430	764090	862161	1039443
1075	53808	77465	137770	180861	215235	382725	598178	767617	866140	1044240
1080	54056	77821	138403	181691	216224	384484	600926	771143	870119	1049038
1085	54303	78177	139036	182522	217213	386242	603674	774670	874098	1053835
1090	54550	78533	139669	183353	218202	388000	606422	778196	878077	1058632
1095	54797	78888	140302	184184	219191	389758	609170	781723	882057	1063430

Orifice Capacities (Contd.)

ASME, B & PVC, Section VIII rating - 2001 Edition pounds per hour saturated steam at 10% overpressure, 90% of actual capacity

W=51.5KAP for "P" less than or equal to 1580 psia

K=.878 (4" Q — K = .792)

W=51.5KAP x [.1906P-1000/.2292P-1061] for "P" greater than 1580 psia

A= flow area in sq. in.

P= (1.10 x set pressure) + 14.7

Apply correction factor for capacities on superheated steam. Correction factor tables begin on page 66. Review pressure temperature limits. Pressure temperature tables begin on page 32. The 1700 is certified as a restricted lift valve and capacities can be restricted down to 30% of its full rated capacity.

Orifice Designation & Area – Square Inches

Orifice Designation Orifice Area Sq. In. Set Pressure (psig)	1 0.994	2 1.431	3 2.545	5 3.341	4 3.976	6 7.07	Q 4"=12.25 6"=11.05	8 14.18	R 16	RR 19.29
1100	55044	79244	140935	185015	220179	391517	611918	785249	886036	1068227
1105	55292	79600	141568	185846	221168	393275	614666	788776	890015	1073024
1110	55539	79956	142200	186677	222157	395033	617414	792302	893994	1077821
1115	55786	80312	142833	187508	223146	396792	620162	795828	897973	1082619
1120	56033	80668	143466	188338	224135	398550	622910	799355	901952	1087416
1125	56281	81024	144099	189169	225124	400308	625659	802881	905931	1092213
1130	56528	81380	144732	190000	226112	402066	628407	806408	909910	1097011
1135	56775	81736	145365	190831	227101	403825	631155	809934	913889	1101808
1140	57022	82091	145998	191662	228090	405583	633903	813461	917868	1106605
1145	57269	82447	146631	192493	229079	407341	636651	816987	921848	1111403
1150	57517	82803	147264	193324	230068	409099	639399	820514	925827	1116200
1155	57764	83159	147897	194155	231056	410858	642147	824040	929806	1120997
1160	58011	83515	148530	194986	232045	412616	644895	827567	933785	1125794
1165	58258	83871	149163	195816	233034	414374	647643	831093	937764	1130592
1170	58505	84227	149796	196647	234023	416132	650391	834620	941743	1135389
1175	58753	84583	150429	197478	235012	417891	653139	838146	945722	1140186
1180	59000	84938	151061	198309	236000	419649	655887	841673	949701	1144984
1185	59247	85294	151694	199140	236989	421407	658635	845199	953680	1149781
1190	59494	85650	152327	199971	237978	423165	661383	848726	957659	1154578
1195	59741	86006	152960	200802	238967	424924	664131	852252	961638	1159375
1200	59989	86362	153593	201633	239956	426682	666879	855779	965618	1164173
1205	60236	86718	154226	202464	240944	428440	669628	859305	969597	1168970
1210	60483	87074	154859	203294	241933	430199	672376	862831	973576	1173767
1215	60730	87430	155492	204125	242922	431957	675124	866358	977555	1178565
1220	60977	87785	156125	204956	243911	433715	677872	869884	981534	1183362
1225	61225	88141	156758	205787	244900	435473	680620	873411	985513	1188159
1230	61472	88497	157391	206618	245888	437232	683368	876937	989492	1192957
1235	61719	88853	158024	207449	246877	438990	686116	880464	993471	1197754
1240	61966	89209	158657	208280	247866	440748	688864	883990	997450	1202551
1245	62213	89565	159289	209111	248855	442506	691612	887517	1001429	1207348
1250	62461	89921	159922	209941	249844	444265	694360	891043	1005409	1212146
1255	62708	90277	160555	210772	250832	446023	697108	894570	1009388	1216943
1260	62955	90633	161188	211603	251821	447781	699856	898096	1013367	1221740
1265	63202	90988	161821	212434	252810	449539	702604	901623	1017346	1226538
1270	63449	91344	162454	213265	253799	451298	705352	905149	1021325	1231335
1275	63697	91700	163087	214096	254788	453056	708100	908676	1025304	1236132
1280	63944	92056	163720	214927	255776	454814	710848	912202	1029283	1240930
1285	64191	92412	164353	215758	256765	456572	713597	915729	1033262	1245727
1290	64438	92768	164986	216589	257754	458331	716345	919255	1037241	1250524
1295	64685	93124	165619	217419	258743	460089	719093	922782	1041220	1255321
1300	64933	93480	166252	218250	259732	461847	721841	926308	1045199	1260119
1305	65180	93835	166885	219081	260721	463606	724589	929834	1049179	1264916
1310	65427	94191	167517	219912	261709	465364	727337	933361	1053158	1269713
1315	65674	94547	168150	220743	262698	467122	730085	936887	1057137	1274511
1320	65921	94903	168783	221574	263687	468880	732833	940414	1061116	1279308
1325	66169	95259	169416	222405	264676	470639	735581	943940	1065095	1284105
1330	66416	95615	170049	223236	265665	472397	738329	947467	1069074	1288903
1335	66663	95971	170682	224067	266653	474155	741077	950993	1073053	1293700
1340	66910	96327	171315	224897	267642	475913	743825	954520	1077032	1298497
1345	67157	96682	171948	225728	268631	477672	746573	958046	1081011	1303294

Orifice Capacities (Contd.)

ASME, B & PVC, Section VIII rating - 2001 Edition pounds per hour saturated steam at 10% overpressure, 90% of actual capacity

W=51.5KAP for "P" less than or equal to 1580 psia

W=51.5KAP x [.1906P-1000/.2292P-1061] for "P" greater than 1580 psia

K=.878 (4" Q - K = .792)

A= flow area in sq. in.

P= (1.10 x set pressure) + 14.7

Apply correction factor for capacities on superheated steam. Correction factor tables begin on page 66. Review pressure temperature limits. Pressure temperature tables begin on page 32. The 1700 is certified as a restricted lift valve and capacities can be restricted down to 30% of its full rated capacity.

Orifice Designation & Area - Square Inches

Orifice Designation Orifice Area Sq. In. Set Pressure (psig)	1 0.994	2 1.431	3 2.545	5 3.341	4 3.976	6 7.07	Q 4"=12.25 6"=11.05	8 14.18	R 16	RR 19.29
1350	67405	97038	172581	226559	269620	479430	749321	961573	1084990	1308092
1355	67652	97394	173214	227390	270609	481188	752069	965099	1088970	1312889
1360	67899	97750	173847	228221	271597	482946	754818	968626	1092949	1317686
1365	68146	98106	174480	229052	272586	484705	757566	972152	1096928	1322484
1370	68393	98462	175113	229883	273575	486463	760314	975679	1100907	1327281
1375	68641	98818	175745	230714	274564	488221	763062	979205	1104886	1332078
1380	68888	99174	176378	231544	275553	489979	765810	982732	1108865	1336876
1385	69135	99530	177011	232375	276541	491738	768558	986258	1112844	1341673
1390	69382	99885	177644	233206	277530	493496	771306	989785	1116823	1346470
1395	69629	100241	178277	234037	278519	495254	774054	993311	1120802	1351267
1400	69877	100597	178910	234868	279508	497013	776802	996837	1124781	1356065
1405	70124	100953	179543	235699	280497	498771	779550	1000364	1128761	1360862
1410	70371	101309	180176	236530	281485	500529	782298	1003890	1132740	1365659
1415	70618	101665	180809	237361	282474	502287	785046	1007417	1136719	1370457
1420	70865	102021	181442	238192	283463	504046	787794	1010943	1140698	1375254
1425	71120	102387	182094	239047	284482	505857	790625	1014576	1144796	1380195
1430	71389	102774	182782	239951	285557	507770	793615	1018413	1149126	1385415
1435	71658	103162	183472	240856	286634	509685	796608	1022253	1153459	1390639
1440	71928	103550	184162	241762	287712	511601	799603	1026097	1157796	1395868
1445	72197	103938	184852	242668	288791	513519	802601	1029944	1162137	1401101
1450	72467	104327	185543	243575	289870	515439	805601	1033794	1166481	1406339
1455	72737	104716	186235	244483	290951	517360	808604	1037648	1170830	1411582
1460	73008	105105	186927	245392	292032	519283	811610	1041505	1175182	1416828
1465	73278	105494	187620	246302	293115	521208	814618	1045365	1179537	1422080
1470	73549	105884	188313	247212	294198	523134	817629	1049229	1183897	1427336
1475	73820	106275	189007	248123	295282	525062	820642	1053096	1188261	1432597
1480	74092	106665	189702	249035	296368	526992	823659	1056967	1192628	1437862
1485	74363	107056	190397	249948	297454	528924	826678	1060841	1197000	1443133
1490	74635	107448	191093	250862	298541	530857	829699	1064718	1201375	1448408
1495	74907	107839	191790	251776	299630	532792	832724	1068600	1205754	1453687
1500	75179	108231	192487	252691	300719	534729	835751	1072484	1210137	1458972
1505	75452	108624	193185	253608	301809	536668	838781	1076372	1214524	1464261
1510	75725	109016	193883	254524	302900	538608	841814	1080264	1218916	1469555
1515	75998	109409	194582	255442	303992	540550	844849	1084159	1223311	1474854
1520	76271	109803	195282	256361	305086	542494	847887	1088058	1227710	1480158
1525	76545	110197	195983	257280	306180	544440	850928	1091961	1232114	1485467
1530	76818	110591	196684	258201	307275	546388	853972	1095867	1236521	1490781
1535	77092	110985	197385	259122	308371	548337	857019	1099777	1240933	1496100
1540	77367	111380	198088	260044	309469	550288	860069	1103690	1245349	1501424
1545	77641	111776	198791	260967	310567	552241	863121	1107607	1249769	1506752
1550	77916	112171	199495	261891	311667	554196	866177	1111528	1254193	1512086
1555	78191	112567	200199	262815	312767	556153	869235	1115453	1258621	1517425
1560	78467	112964	200904	263741	313868	558112	872296	1119381	1263054	1522769
1565	78742	113361	201610	264667	314971	560072	875361	1123314	1267491	1528119
1570	79018	113758	202316	265595	316075	562035	878428	1127250	1271932	1533473
1575	79294	114156	203023	266523	317179	563999	881498	1131189	1276377	1538833
1580	79571	114554	203731	267452	318285	565965	884571	1135133	1280827	1544197
1585	79848	114952	204440	268382	319392	567933	887647	1139081	1285282	1549568
1590	80125	115351	205149	269313	320500	569904	890727	1143032	1289740	1554943
1595	80402	115750	205859	270245	321609	571876	893809	1146988	1294203	1560324

Orifice Capacities (Contd.)

ASME, B & PVC, Section VIII rating - 2001 Edition pounds per hour saturated steam at 10% overpressure, 90% of actual capacity

W=51.5KAP for "P" less than or equal to 1580 psia

K=.878 (4" Q — K = .792)

W=51.5KAP x [.1906P-1000/.2292P-1061] for "P" greater than 1580 psia

A= flow area in sq. in.

P= (1.10 x set pressure) + 14.7

Apply correction factor for capacities on superheated steam. Correction factor tables begin on page 66. Review pressure temperature limits. Pressure temperature tables begin on page 32. The 1700 is certified as a restricted lift valve and capacities can be restricted down to 30% of its full rated capacity.

Orifice Designation & Area – Square Inches

Orifice Designation Orifice Area Sq. In. Set Pressure (psig)	1 0.994	2 1.431	3 2.545	5 3.341	4 3.976	6 7.07	Q 4"=12.25 6"=11.05	8 14.18	R 16	RR 19.29
1600	80679	116149	206569	271178	322719	573850	896894	1150947	1298671	1565710
1605	80957	116549	207281	272112	323831	575826	-	-	-	-
1610	81235	116950	207993	273047	324943	577804	-	-	-	-
1615	81514	117351	208706	273983	326057	579784	-	-	-	-
1620	81792	117752	209419	274919	327171	581766	-	-	-	-
1625	82071	118153	210133	275857	328287	583750	-	-	-	-
1630	82351	118555	210848	276795	329404	585736	-	-	-	-
1635	82630	118958	211564	277735	330522	587724	-	-	-	-
1640	82910	119361	212280	278675	331641	589715	-	-	-	-
1645	83190	119764	212997	279617	332762	591707	-	-	-	-
1650	83470	120167	213715	280559	333883	593701	-	-	-	-
1655	83751	120572	214434	281503	335006	595698	-	-	-	-
1660	84032	120976	215153	282447	336130	597696	-	-	-	-
1665	84313	121381	215874	283393	337255	599697	-	-	-	-
1670	84595	121786	216595	284339	338382	601700	-	-	-	-
1675	84877	122192	217316	285287	339509	603705	-	-	-	-
1680	85159	122598	218039	286235	340638	605712	-	-	-	-
1685	85442	123005	218762	287185	341768	607721	-	-	-	-
1690	85724	123412	219486	288135	342899	609733	-	-	-	-
1695	86007	123820	220211	289087	344031	611746	-	-	-	-
1700	86291	124228	220937	290039	345165	613762	-	-	-	-
1705	86575	124636	221663	290993	346300	615781	-	-	-	-
1710	86859	125045	222391	291948	347436	617801	-	-	-	-
1715	87143	125455	223119	292904	348574	619823	-	-	-	-
1720	87428	125865	223847	293860	349713	621848	-	-	-	-
1725	87713	126275	224577	294818	350853	623876	-	-	-	-
1730	87998	126686	225308	295777	351994	625905	-	-	-	-
1735	88284	127097	226039	296738	353136	627937	-	-	-	-
1740	88570	127509	226771	297699	354280	629971	-	-	-	-
1745	88856	127921	227504	298661	355426	632007	-	-	-	-
1750	89143	128333	228238	299625	356572	634046	-	-	-	-
1755	89430	128747	228973	300589	357720	636087	-	-	-	-
1760	89717	129160	229709	301555	358869	638131	-	-	-	-
1765	90005	129574	230445	302522	360020	640176	-	-	-	-
1770	90293	129989	231182	303490	361172	642225	-	-	-	-
1775	90581	130404	231921	304459	362325	644275	-	-	-	-
1780	90870	130819	232660	305429	363480	646329	-	-	-	-
1785	91159	131236	233400	306400	364636	648384	-	-	-	-
1790	91448	131652	234141	307373	365793	650442	-	-	-	-
1795	91738	132069	234882	308347	366952	652503	-	-	-	-
1800	92028	132487	235625	309321	368112	654566	-	-	-	-
1805	92318	132905	236368	310298	369274	656631	-	-	-	-
1810	92609	133323	237113	311275	370437	658700	-	-	-	-
1815	92900	133742	237858	312253	371601	660770	-	-	-	-
1820	93191	134162	238605	313233	372767	662843	-	-	-	-
1825	93483	134582	239352	314214	373935	664919	-	-	-	-
1830	93775	135003	240100	315196	375103	666998	-	-	-	-
1835	94068	135424	240849	316180	376274	669079	-	-	-	-
1840	94361	135846	241599	317164	377445	671162	-	-	-	-
1845	94654	136268	242350	318150	378619	673249	-	-	-	-

Orifice Capacities (Contd.)

ASME, B & PVC, Section VIII rating - 2001 Edition

pounds per hour saturated steam at 10% overpressure, 90% of actual capacity

W=51.5KAP for "P" less than or equal to 1580 psia

W=51.5KAP x [.1906P-1000/.2292P-1061] for "P" greater than 1580 psia

K=.878 (4" Q — K = .792)

A= flow area in sq. in.

P= (1.10 x set pressure) + 14.7

Apply correction factor for capacities on superheated steam. Correction factor tables begin on page 66. Review pressure temperature limits. Pressure temperature tables begin on page 32. The 1700 is certified as a restricted lift valve and capacities can be restricted down to 30% of its full rated capacity.

Orifice Designation & Area – Square Inches

Orifice Designation Orifice Area Sq. In. Set Pressure (psig)	1 0.994	2 1.431	3 2.545	5 3.341	4 3.976	6 7.07	Q 4"=12.25 6"=11.05	8 14.18	R 16	RR 19.29
1850	94948	136691	243102	319137	379794	675337	-	-	-	-
1855	95242	137114	243855	320126	380970	677429	-	-	-	-
1860	95537	137538	244609	321115	382148	679523	-	-	-	-
1865	95831	137963	245364	322106	383327	681620	-	-	-	-
1870	96127	138388	246120	323099	384508	683720	-	-	-	-
1875	96422	138813	246876	324092	385690	685823	-	-	-	-
1880	96718	139239	247634	325087	386874	687928	-	-	-	-
1885	97015	139666	248393	326083	388060	690036	-	-	-	-
1890	97311	140093	249153	327081	389247	692147	-	-	-	-
1895	97608	140521	249914	328080	390435	694260	-	-	-	-
1900	97906	140949	250676	329080	391626	696377	-	-	-	-
1905	98204	141378	251439	330081	392818	698496	-	-	-	-
1910	98502	141808	252203	331084	394011	700619	-	-	-	-
1915	98801	142238	252968	332088	395206	702744	-	-	-	-
1920	99100	142669	253734	333094	396403	704872	-	-	-	-
1925	99400	143100	254501	334101	397601	707003	-	-	-	-
1930	99700	143532	255269	335109	398801	709137	-	-	-	-
1935	100000	143965	256038	336119	400003	711274	-	-	-	-
1940	100301	144398	256808	337130	401207	713413	-	-	-	-
1945	100603	144831	257580	338143	402412	715556	-	-	-	-
1950	100904	145266	258352	339157	403619	717702	-	-	-	-
1955	101206	145701	259126	340173	404827	719851	-	-	-	-
1960	101509	146136	259900	341190	406037	722003	-	-	-	-
1965	101812	146573	260676	342208	407249	724159	-	-	-	-
1970	102115	147009	261453	343228	408463	726317	-	-	-	-
1975	102419	147447	262231	344250	409679	728478	-	-	-	-
1980	102724	147885	263010	345272	410896	730643	-	-	-	-
1985	103028	148324	263791	346297	412115	732811	-	-	-	-
1990	103334	148763	264572	347323	413336	734982	-	-	-	-
1995	103639	149203	265355	348350	414559	737156	-	-	-	-
2000	103945	149644	266139	349379	415783	739333	-	-	-	-
2005	104252	150085	266924	350410	417010	741514	-	-	-	-
2010	104559	150527	267710	351442	418238	743698	-	-	-	-
2015	104867	150970	268497	352475	419468	745885	-	-	-	-
2020	105175	151414	269286	353510	420700	748076	-	-	-	-
2025	105483	151858	270076	354547	421934	750270	-	-	-	-
2030	105792	152302	270867	355586	423169	752467	-	-	-	-
2035	106101	152748	271659	356626	424407	754668	-	-	-	-
2040	106411	153194	272452	357667	425647	756872	-	-	-	-
2045	106722	153641	273247	358710	426888	759080	-	-	-	-
2050	107033	154088	274043	359755	428132	761291	-	-	-	-
2055	107344	154537	274840	360802	429377	763505	-	-	-	-
2060	107656	154985	275638	361850	430624	765723	-	-	-	-
2065	107968	155435	276438	362900	431874	767945	-	-	-	-
2070	108281	155886	277239	363952	433125	770170	-	-	-	-
2075	108594	156337	278042	365005	434379	772399	-	-	-	-
2080	108908	156789	278845	366060	435634	774632	-	-	-	-
2085	109223	157241	279650	367117	436892	776868	-	-	-	-
2090	109537	157695	280456	368175	438151	779108	-	-	-	-
2095	109853	158149	281264	369235	439413	781351	-	-	-	-

Orifice Capacities (Contd.)

ASME, B & PVC, Section VIII rating - 2001 Edition pounds per hour saturated steam at 10% overpressure, 90% of actual capacity

W=51.5KAP for "P" less than or equal to 1580 psia

K=.878 (4" Q — K = .792)

W=51.5KAP x [.1906P-1000/.2292P-1061] for "P" greater than 1580 psia

A= flow area in sq. in.

P= (1.10 x set pressure) + 14.7

Apply correction factor for capacities on superheated steam. Correction factor tables begin on page 66. Review pressure temperature limits. Pressure temperature tables begin on page 32. The 1700 is certified as a restricted lift valve and capacities can be restricted down to 30% of its full rated capacity.

Orifice Designation & Area – Square Inches

Orifice Designation Orifice Area Sq. In. Set Pressure (psig)	1 0.994	2 1.431	3 2.545	5 3.341	4 3.976	6 7.07	Q 4"=12.25 6"=11.05	8 14.18	R 16	RR 19.29
2100	110169	158603	282073	370297	440677	783598	-	-	-	-
2105	110485	159059	282883	371361	441943	785849	-	-	-	-
2110	110802	159515	283695	372426	443211	788104	-	-	-	-
2115	111120	159973	284508	373494	444481	790363	-	-	-	-
2120	111438	160431	285322	374563	445753	792625	-	-	-	-
2125	111757	160889	286138	375634	447028	794892	-	-	-	-
2130	112076	161349	286955	376707	448305	797162	-	-	-	-
2135	112396	161809	287774	377781	449584	799436	-	-	-	-
2140	112716	162270	288594	378858	450865	801714	-	-	-	-
2145	113037	162732	289416	379936	452148	803996	-	-	-	-
2150	113358	163195	290238	381016	453434	806282	-	-	-	-
2155	113680	163658	291063	382099	454722	808572	-	-	-	-
2160	114003	164123	291889	383183	456012	810866	-	-	-	-
2165	114326	164588	292716	384269	457304	813165	-	-	-	-
2170	114649	165054	293545	385357	458599	815467	-	-	-	-
2175	114974	165521	294375	386447	459896	817774	-	-	-	-
2180	115299	165988	295207	387539	461196	820084	-	-	-	-
2185	115624	166457	296040	388633	462498	822399	-	-	-	-
2190	115950	166926	296875	389729	463802	824719	-	-	-	-
2195	116277	167397	297711	390827	465109	827042	-	-	-	-
2200	116604	167868	298549	391927	466418	829370	-	-	-	-
2205	116932	168340	299389	393029	467729	831702	-	-	-	-
2210	117260	168813	300230	394133	469043	834039	-	-	-	-
2215	117590	169287	301073	395239	470360	836380	-	-	-	-
2220	117919	169761	301917	396348	471679	838725	-	-	-	-
2225	118250	170237	302763	397458	473000	841075	-	-	-	-
2230	118581	170714	303610	398571	474324	843429	-	-	-	-
2235	118912	171191	304460	399686	475651	845788	-	-	-	-
2240	119245	171669	305310	400802	476980	848152	-	-	-	-
2245	119578	172149	306163	401922	478312	850520	-	-	-	-
2250	119911	172629	307017	403043	479646	852893	-	-	-	-
2255	120246	173110	307873	404166	480984	855270	-	-	-	-
2260	120580	173592	308730	405292	482323	857653	-	-	-	-
2265	120916	174076	309590	406420	483666	860040	-	-	-	-
2270	121252	174560	310451	407551	485011	862432	-	-	-	-
2275	121589	175045	311313	408683	486359	864828	-	-	-	-
2280	121927	175531	312178	409818	487709	867230	-	-	-	-
2285	122265	176018	313044	410955	489063	869636	-	-	-	-
2290	122604	176506	313912	412095	490419	872048	-	-	-	-
2295	122944	176995	314782	413237	491778	874464	-	-	-	-
2300	123284	177485	315654	414381	493139	876886	-	-	-	-
2305	123626	177976	316527	415528	494504	879312	-	-	-	-
2310	123968	178469	317403	416677	495872	881744	-	-	-	-
2315	124310	178962	318280	417828	497242	884181	-	-	-	-
2320	124653	179456	319159	418982	498615	886623	-	-	-	-
2325	124998	179951	320040	420139	499992	889070	-	-	-	-
2330	125342	180448	320923	421298	501371	891523	-	-	-	-
2335	125688	180945	321807	422459	502753	893980	-	-	-	-
2340	126034	181444	322694	423623	504138	896444	-	-	-	-
2345	126381	181944	323583	424790	505527	898912	-	-	-	-

Orifice Capacities (Contd.)

ASME, B & PVC, Section VIII rating - 2001 Edition

pounds per hour saturated steam at 10% overpressure, 90% of actual capacity

W=51.5KAP for "P" less than or equal to 1580 psia

W=51.5KAP x [.1906P-1000/.2292P-1061] for "P" greater than 1580 psia

K=.878 (4" Q — K = .792)

A= flow area in sq. in.

P= (1.10 x set pressure) + 14.7

Apply correction factor for capacities on superheated steam. Correction factor tables begin on page 66. Review pressure temperature limits. Pressure temperature tables begin on page 32. The 1700 is certified as a restricted lift valve and capacities can be restricted down to 30% of its full rated capacity.

Orifice Designation & Area – Square Inches

Orifice Designation Orifice Area Sq. In. Set Pressure (psig)	1 0.994	2 1.431	3 2.545	5 3.341	4 3.976	6 7.07	Q 4"=12.25 6"=11.05	8 14.18	R 16	RR 19.29
2350	126729	182444	324473	425959	506918	901386	-	-	-	-
2355	127078	182946	325366	427131	508313	903866	-	-	-	-
2360	127427	183449	326260	428305	509710	906351	-	-	-	-
2365	127777	183953	327157	429482	511111	908842	-	-	-	-
2370	128128	184459	328056	430662	512515	911338	-	-	-	-
2375	128480	184965	328956	431844	513922	913840	-	-	-	-
2380	128833	185473	329859	433029	515332	916348	-	-	-	-
2385	129186	185981	330764	434217	516746	918862	-	-	-	-
2390	129540	186491	331671	435408	518163	921381	-	-	-	-
2395	129895	187002	332580	436601	519583	923906	-	-	-	-
2400	130251	187515	333491	437797	521006	926438	-	-	-	-
2405	130608	188028	334404	438996	522433	928975	-	-	-	-
2410	130965	188543	335320	440198	523863	931518	-	-	-	-
2415	131324	189059	336237	441403	525297	934067	-	-	-	-
2420	131683	189576	337157	442610	526734	936623	-	-	-	-
2425	132043	190095	338079	443821	528175	939184	-	-	-	-
2430	132404	190614	339004	445034	529619	941752	-	-	-	-
2435	132766	191135	339930	446251	531066	944326	-	-	-	-
2440	133129	191658	340859	447470	532517	946906	-	-	-	-
2445	133493	192181	341790	448692	533972	949493	-	-	-	-
2450	133857	192706	342724	449918	535431	952086	-	-	-	-
2455	134223	193232	343660	451146	536893	954686	-	-	-	-
2460	134589	193760	344598	452378	538358	957292	-	-	-	-
2465	134957	194289	345538	453613	539828	959905	-	-	-	-
2470	135325	194819	346481	454851	541301	962525	-	-	-	-
2475	135694	195351	347427	456092	542778	965151	-	-	-	-
2480	136064	195884	348375	457336	544259	967784	-	-	-	-
2485	136435	196418	349325	458584	545743	970424	-	-	-	-
2490	136808	196954	350278	459834	547232	973071	-	-	-	-
2495	137181	197491	351233	461088	548724	975725	-	-	-	-
2500	137555	198029	352191	462346	550221	978386	-	-	-	-
2505	137930	198569	353151	463607	551721	981054	-	-	-	-
2510	138306	199111	354114	464871	553226	983729	-	-	-	-
2515	138683	199654	355080	466138	554734	986411	-	-	-	-
2520	139061	200198	356048	467409	556247	989101	-	-	-	-
2525	139440	200744	357019	468684	557763	991798	-	-	-	-
2530	139821	201291	357992	469962	559284	994502	-	-	-	-
2535	140202	201840	358969	471243	560809	997214	-	-	-	-
2540	140584	202391	359947	472528	562339	999933	-	-	-	-
2545	140968	202943	360929	473817	563872	1002661	-	-	-	-
2550	141352	203496	361914	475109	565410	1005395	-	-	-	-
2555	141738	204051	362901	476405	566952	1008138	-	-	-	-
2560	142124	204608	363891	477705	568499	1010888	-	-	-	-
2565	142512	205166	364884	479009	570050	1013646	-	-	-	-
2570	142901	205726	365879	480316	571606	1016412	-	-	-	-
2575	143291	206288	366878	481627	573166	1019187	-	-	-	-
2580	143682	206851	367880	482942	574731	1021969	-	-	-	-
2585	144075	207416	368884	484260	576300	1024760	-	-	-	-
2590	144468	207982	369892	485583	577874	1027558	-	-	-	-
2595	144863	208550	370902	486909	579453	1030366	-	-	-	-

Orifice Capacities (Contd.)

ASME, B & PVC, Section VIII rating - 2001 Edition pounds per hour saturated steam at 10% overpressure, 90% of actual capacity

W=51.5KAP for "P" less than or equal to 1580 psia

K=.878 (4" Q — K = .792)

W=51.5KAP x [.1906P-1000/.2292P-1061] for "P" greater than 1580 psia

A= flow area in sq. in.

P= (1.10 x set pressure) + 14.7

Apply correction factor for capacities on superheated steam. Correction factor tables begin on page 66. Review pressure temperature limits. Pressure temperature tables begin on page 32. The 1700 is certified as a restricted lift valve and capacities can be restricted down to 30% of its full rated capacity.

Orifice Designation & Area – Square Inches

Orifice Designation Orifice Area Sq. In. Set Pressure (psig)	1 0.994	2 1.431	3 2.545	5 3.341	4 3.976	6 7.07	Q 4"=12.25 6"=11.05	8 14.18	R 16	RR 19.29
2600	145259	209120	371916	488240	581036	1033181	-	-	-	-
2605	145656	209692	372932	489575	582625	1036005	-	-	-	-
2610	146054	210265	373952	490913	584218	1038838	-	-	-	-
2615	146454	210840	374975	492256	585816	1041680	-	-	-	-
2620	146854	211417	376001	493603	587418	1044530	-	-	-	-
2625	147256	211996	377030	494954	589026	1047389	-	-	-	-
2630	147659	212576	378062	496309	590639	1050257	-	-	-	-
2635	148064	213159	379098	497669	592257	1053134	-	-	-	-
2640	148470	213743	380137	499033	593880	1056020	-	-	-	-
2645	148877	214329	381179	500401	595508	1058915	-	-	-	-
2650	149285	214917	382225	501773	597142	1061819	-	-	-	-
2655	149695	215506	383274	503150	598781	1064733	-	-	-	-
2660	150106	216098	384326	504532	600425	1067657	-	-	-	-
2665	150518	216692	385382	505918	602074	1070590	-	-	-	-
2670	150932	217287	386441	507308	603729	1073532	-	-	-	-
2675	151347	217885	387504	508703	605389	1076484	-	-	-	-
2680	151763	218484	388570	510103	607055	1079446	-	-	-	-
2685	152181	219086	389640	511508	608726	1082418	-	-	-	-
2690	152600	219690	390713	512917	610403	1085401	-	-	-	-
2695	153021	220295	391790	514331	612086	1088393	-	-	-	-
2700	153443	220903	392871	515750	613775	1091395	-	-	-	-
2705	153867	221513	393956	517173	615469	1094408	-	-	-	-
2710	154292	222125	395044	518602	617169	1097431	-	-	-	-
2715	154718	222739	396136	520036	618875	1100465	-	-	-	-
2720	155146	223355	397232	521474	620587	1103509	-	-	-	-
2725	155576	223973	398332	522918	622305	1106565	-	-	-	-
2730	156007	224594	399435	524367	624030	1109631	-	-	-	-
2735	156440	225217	400543	525821	625760	1112708	-	-	-	-
2740	156874	225842	401655	527280	627497	1115796	-	-	-	-
2745	157310	226469	402770	528745	629240	1118895	-	-	-	-
2750	157747	227099	403890	530215	630989	1122006	-	-	-	-
2755	158186	227731	405014	531690	632745	1125128	-	-	-	-
2760	158626	228365	406142	533171	634507	1128262	-	-	-	-
2765	159069	229002	407274	534658	636276	1131407	-	-	-	-
2770	159513	229641	408411	536150	638052	1134564	-	-	-	-
2775	159958	230282	409552	537647	639834	1137734	-	-	-	-
2780	160405	230926	410697	539151	641623	1140915	-	-	-	-
2785	160854	231572	411846	540660	643419	1144108	-	-	-	-
2790	161305	232221	413000	542174	645222	1147314	-	-	-	-
2795	161758	232872	414159	543695	647032	1150532	-	-	-	-
2800	162212	233526	415322	545222	648849	1153763	-	-	-	-
2805	162668	234183	416489	546755	650673	1157006	-	-	-	-
2810	163126	234842	417661	548294	652504	1160263	-	-	-	-
2815	163585	235504	418838	549839	654343	1163532	-	-	-	-
2820	164047	236168	420020	551390	656189	1166815	-	-	-	-
2825	164510	236835	421206	552947	658042	1170110	-	-	-	-
2830	164975	237505	422398	554511	659903	1173420	-	-	-	-
2835	165443	238178	423594	556081	661772	1176742	-	-	-	-
2840	165912	238853	424795	557658	663648	1180079	-	-	-	-
2845	166383	239531	426001	559241	665532	1183429	-	-	-	-

Orifice Capacities (Contd.)

ASME, B & PVC, Section VIII rating - 2001 Edition

pounds per hour saturated steam at 10% overpressure, 90% of actual capacity

W=51.5KAP for "P" less than or equal to 1580 psia

W=51.5KAP x [.1906P-1000/.2292P-1061] for "P" greater than 1580 psia

K=.878 (4" Q — K = .792)

A= flow area in sq. in.

P= (1.10 x set pressure) + 14.7

Apply correction factor for capacities on superheated steam. Correction factor tables begin on page 66. Review pressure temperature limits. Pressure temperature tables begin on page 32. The 1700 is certified as a restricted lift valve and capacities can be restricted down to 30% of its full rated capacity.

Orifice Designation & Area – Square Inches

Orifice Designation Orifice Area Sq. In. Set Pressure (psig)	1 0.994	2 1.431	3 2.545	5 3.341	4 3.976	6 7.07	Q 4"=12.25 6"=11.05	8 14.18	R 16	RR 19.29
2850	166856	240212	427212	560831	667424	1186794	-	-	-	-
2855	167331	240896	428428	562428	669324	1190172	-	-	-	-
2860	167808	241583	429649	564031	671233	1193565	-	-	-	-
2865	168287	242272	430876	565641	673149	1196973	-	-	-	-
2870	168768	242965	432108	567259	675074	1200395	-	-	-	-
2875	169251	243661	433345	568883	677006	1203832	-	-	-	-
2880	169737	244359	434588	570514	678948	1207284	-	-	-	-
2885	170224	245061	435836	572153	680898	1210752	-	-	-	-
2890	170714	245766	437090	573798	682856	1214234	-	-	-	-
2895	171206	246474	438349	575452	684824	1217732	-	-	-	-

Orifice Capacities (Contd.)

Superheat Correction Factor

Notes:

1. For capacity on superheated steam, multiply saturated steam capacity by correction factor.
2. Convert set pressure from (psig) to (psia) flowing pressure.
3. PSIA flowing = [set pressure psig x overpressure] + 14.7

Flowing Pressure ³ (psia)	Superheat Correction Factor Ksh Total Temperature, °F, of Superheated Steam																
	400	450	500	550	600	650	700	750	800	850	900	950	1000	1050	1100	1150	1200
50	0.987	0.957	0.930	0.905	0.882	0.861	0.841	0.823	0.805	0.789	0.774	0.759	0.745	0.732	0.719	0.708	0.696
100	0.998	0.963	0.935	0.909	0.885	0.864	0.843	0.825	0.807	0.790	0.775	0.760	0.746	0.733	0.720	0.708	0.697
150	0.984	0.970	0.940	0.913	0.888	0.866	0.846	0.826	0.808	0.792	0.776	0.761	0.747	0.733	0.721	0.709	0.697
200	0.979	0.977	0.945	0.917	0.892	0.869	0.848	0.828	0.810	0.793	0.777	0.762	0.748	0.734	0.721	0.709	0.698
250	-	0.972	0.951	0.921	0.895	0.871	0.850	0.830	0.812	0.794	0.778	0.763	0.749	0.735	0.722	0.710	0.698
300	-	0.968	0.957	0.926	0.898	0.874	0.852	0.832	0.813	0.796	0.780	0.764	0.750	0.736	0.723	0.710	0.699
350	-	0.968	0.963	0.930	0.902	0.877	0.854	0.834	0.815	0.797	0.781	0.765	0.750	0.736	0.723	0.711	0.699
400	-	-	0.963	0.935	0.906	0.880	0.857	0.836	0.816	0.798	0.782	0.766	0.751	0.737	0.724	0.712	0.700
450	-	-	0.961	0.940	0.909	0.883	0.859	0.838	0.818	0.800	0.783	0.767	0.752	0.738	0.725	0.712	0.700
500	-	-	0.961	0.946	0.914	0.886	0.862	0.840	0.820	0.801	0.784	0.768	0.753	0.739	0.725	0.713	0.701
550	-	-	0.962	0.952	0.918	0.889	0.864	0.842	0.822	0.803	0.785	0.769	0.754	0.740	0.726	0.713	0.701
600	-	-	0.964	0.958	0.922	0.892	0.867	0.844	0.823	0.804	0.787	0.770	0.755	0.740	0.727	0.714	0.702
650	-	-	0.968	0.958	0.927	0.896	0.869	0.846	0.825	0.806	0.788	0.771	0.756	0.741	0.728	0.715	0.702
700	-	-	-	0.958	0.931	0.899	0.872	0.848	0.827	0.807	0.789	0.772	0.757	0.742	0.728	0.715	0.703
750	-	-	-	0.958	0.936	0.903	0.875	0.850	0.828	0.809	0.790	0.774	0.758	0.743	0.729	0.716	0.703
800	-	-	-	0.960	0.942	0.906	0.878	0.852	0.830	0.810	0.792	0.774	0.759	0.744	0.730	0.716	0.704
850	-	-	-	0.962	0.947	0.910	0.880	0.855	0.832	0.812	0.793	0.776	0.760	0.744	0.730	0.717	0.704
900	-	-	-	0.965	0.953	0.914	0.883	0.857	0.834	0.813	0.794	0.777	0.760	0.745	0.731	0.718	0.705
950	-	-	-	0.969	0.958	0.918	0.886	0.860	0.836	0.815	0.796	0.778	0.761	0.746	0.732	0.718	0.705
1000	-	-	-	0.974	0.959	0.923	0.890	0.862	0.838	0.816	0.797	0.779	0.762	0.747	0.732	0.719	0.706
1050	-	-	-	-	0.960	0.927	0.893	0.864	0.840	0.818	0.798	0.780	0.763	0.748	0.733	0.719	0.707
1100	-	-	-	-	0.962	0.931	0.896	0.867	0.842	0.820	0.800	0.781	0.764	0.749	0.734	0.720	0.707
1150	-	-	-	-	0.964	0.936	0.899	0.870	0.844	0.821	0.801	0.782	0.765	0.749	0.735	0.721	0.708
1200	-	-	-	-	0.966	0.941	0.903	0.872	0.846	0.823	0.802	0.784	0.766	0.750	0.735	0.721	0.708
1250	-	-	-	-	0.969	0.946	0.906	0.875	0.848	0.825	0.804	0.785	0.767	0.751	0.736	0.722	0.709
1300	-	-	-	-	0.973	0.952	0.910	0.878	0.850	0.826	0.805	0.786	0.768	0.752	0.737	0.723	0.709
1350	-	-	-	-	0.977	0.958	0.914	0.880	0.852	0.828	0.807	0.787	0.769	0.753	0.737	0.723	0.710
1400	-	-	-	-	0.982	0.963	0.918	0.883	0.854	0.830	0.808	0.788	0.770	0.754	0.738	0.724	0.710
1450	-	-	-	-	0.987	0.968	0.922	0.886	0.857	0.832	0.809	0.790	0.771	0.754	0.739	0.724	0.711
1500	-	-	-	-	0.993	0.970	0.926	0.889	0.859	0.833	0.811	0.791	0.772	0.755	0.740	0.725	0.711
1550	-	-	-	-	-	0.972	0.930	0.892	0.861	0.835	0.812	0.792	0.773	0.756	0.740	0.726	0.712
1600	-	-	-	-	-	0.973	0.934	0.894	0.863	0.836	0.813	0.792	0.774	0.756	0.740	0.726	0.712
1650	-	-	-	-	-	0.973	0.936	0.895	0.863	0.836	0.812	0.791	0.772	0.755	0.739	0.724	0.710
1700	-	-	-	-	-	0.973	0.938	0.895	0.863	0.835	0.811	0.790	0.771	0.754	0.738	0.723	0.709
1750	-	-	-	-	-	0.974	0.940	0.896	0.862	0.835	0.810	0.789	0.770	0.752	0.736	0.721	0.707
1800	-	-	-	-	-	0.975	0.942	0.897	0.862	0.834	0.810	0.788	0.768	0.751	0.735	0.720	0.705
1850	-	-	-	-	-	0.976	0.944	0.897	0.862	0.833	0.809	0.787	0.767	0.749	0.733	0.718	0.704
1900	-	-	-	-	-	0.977	0.946	0.898	0.862	0.832	0.807	0.785	0.766	0.748	0.731	0.716	0.702
1950	-	-	-	-	-	0.979	0.949	0.898	0.861	0.832	0.806	0.784	0.764	0.746	0.729	0.714	0.700
2000	-	-	-	-	-	0.982	0.952	0.899	0.861	0.831	0.805	0.782	0.762	0.744	0.728	0.712	0.698
2050	-	-	-	-	-	0.985	0.954	0.899	0.860	0.830	0.804	0.781	0.761	0.742	0.726	0.710	0.696
2100	-	-	-	-	-	0.988	0.956	0.900	0.860	0.828	0.802	0.779	0.759	0.740	0.724	0.708	0.694
2150	-	-	-	-	-	-	0.956	0.900	0.859	0.827	0.801	0.778	0.757	0.738	0.722	0.706	0.692
2200	-	-	-	-	-	-	0.955	0.901	0.859	0.826	0.799	0.776	0.755	0.736	0.720	0.704	0.690
2250	-	-	-	-	-	-	0.954	0.901	0.858	0.825	0.797	0.774	0.753	0.734	0.717	0.702	0.687
2300	-	-	-	-	-	-	0.953	0.901	0.857	0.823	0.795	0.772	0.751	0.732	0.715	0.699	0.685
2350	-	-	-	-	-	-	0.952	0.902	0.856	0.822	0.794	0.769	0.748	0.729	0.712	0.697	0.682
2400	-	-	-	-	-	-	0.952	0.902	0.855	0.820	0.791	0.767	0.746	0.727	0.710	0.694	0.679
2450	-	-	-	-	-	-	0.951	0.902	0.854	0.818	0.789	0.765	0.743	0.724	0.707	0.691	0.677
2500	-	-	-	-	-	-	0.951	0.902	0.852	0.816	0.787	0.762	0.740	0.721	0.704	0.688	0.674
2550	-	-	-	-	-	-	0.951	0.902	0.851	0.814	0.784	0.759	0.738	0.718	0.701	0.685	0.671
2600	-	-	-	-	-	-	0.951	0.903	0.849	0.812	0.782	0.756	0.735	0.715	0.698	0.682	0.664
2650	-	-	-	-	-	-	0.952	0.903	0.848	0.809	0.779	0.754	0.731	0.712	0.695	0.679	0.664
2700	-	-	-	-	-	-	0.952	0.903	0.846	0.807	0.776	0.750	0.728	0.708	0.691	0.675	0.661
2750	-	-	-	-	-	-	0.953	0.903	0.844	0.804	0.773	0.747	0.724	0.705	0.687	0.671	0.657
2800	-	-	-	-	-	-	0.956	0.903	0.842	0.801	0.769	0.743	0.721	0.701	0.684	0.668	0.653
2850	-	-	-	-	-	-	0.959	0.902	0.839	0.798	0.766	0.739	0.717	0.697	0.679	0.663	0.649
2900	-	-	-	-	-	-	0.963	0.902	0.836	0.794	0.762	0.735	0.713	0.693	0.675	0.659	0.645
2950	-	-	-	-	-	-	-	0.902	0.834	0.790	0.758	0.731	0.708	0.688	0.671	0.655	0.640
3000	-	-	-	-	-	-	-	0.901	0.831	0.786	0.753	0.726	0.704	0.684	0.666	0.650	0.635
3050	-	-	-	-	-	-	-	0.899	0.827	0.782	0.749	0.722	0.699	0.679	0.661	0.645	0.630
3100	-	-	-	-	-	-	-	0.896	0.823	0.777	0.744	0.716	0.693	0.673	0.656	0.640	0.625
3150	-	-	-	-	-	-	-	0.894	0.819	0.772	0.738	0.711	0.688	0.668	0.650	0.634	0.620
3200	-	-	-	-	-	-	-	0.889	0.815	0.767	0.733	0.705	0.682	0.662	0.644	0.628	0.614

Hydrostatic Test Plugs

For butt-weld inlet valves shipped, hydrostatic test plugs are normally installed to increase “set point” approximately 1.5 times the valve set pressure for hydrostatic testing. It is strongly recommended that hydrostatic test plugs be used, in conjunction with proper gag and gagging procedure, during hydrostatic testing to avoid valve component damage.

For flanged inlet valves shipped, hydrostatic test plugs are not normally installed. It is suggested that the valve not be installed until after the unit hydrostatic test has been performed utilizing “blind” flanges to blank-off the unit nozzles.

Note 1: Hydrostatic plugs may be added or deleted upon specific request.

Note 2: Consult maintenance manual for hydrostatic test and gag procedures.

1700 Series Safety Valve

Inlet Type	Hydrostatic Test Plugs ¹ Installed Before Shipping
Flanged Inlet	No
Butt-weld Inlet	Yes

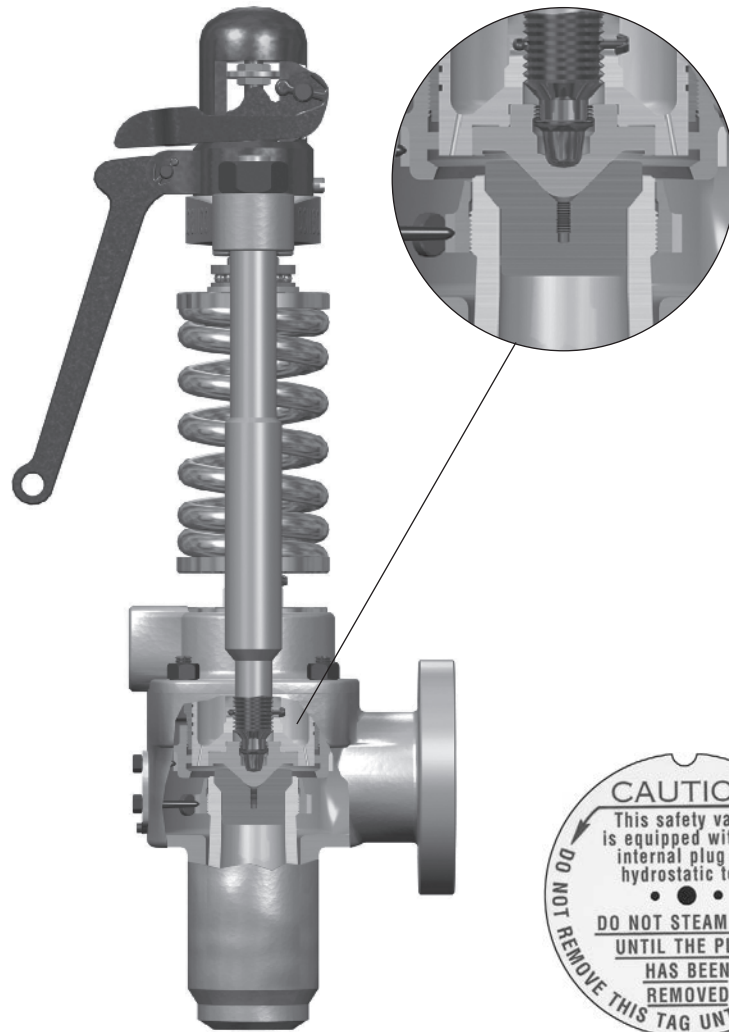

1700

Valves shipped with hydroplug are identified by a Red on White Caution Tag which is attached to the valve by wires extending through the drain hole in the valve body.

Valve Configuration Code

1700 Series Main Valve

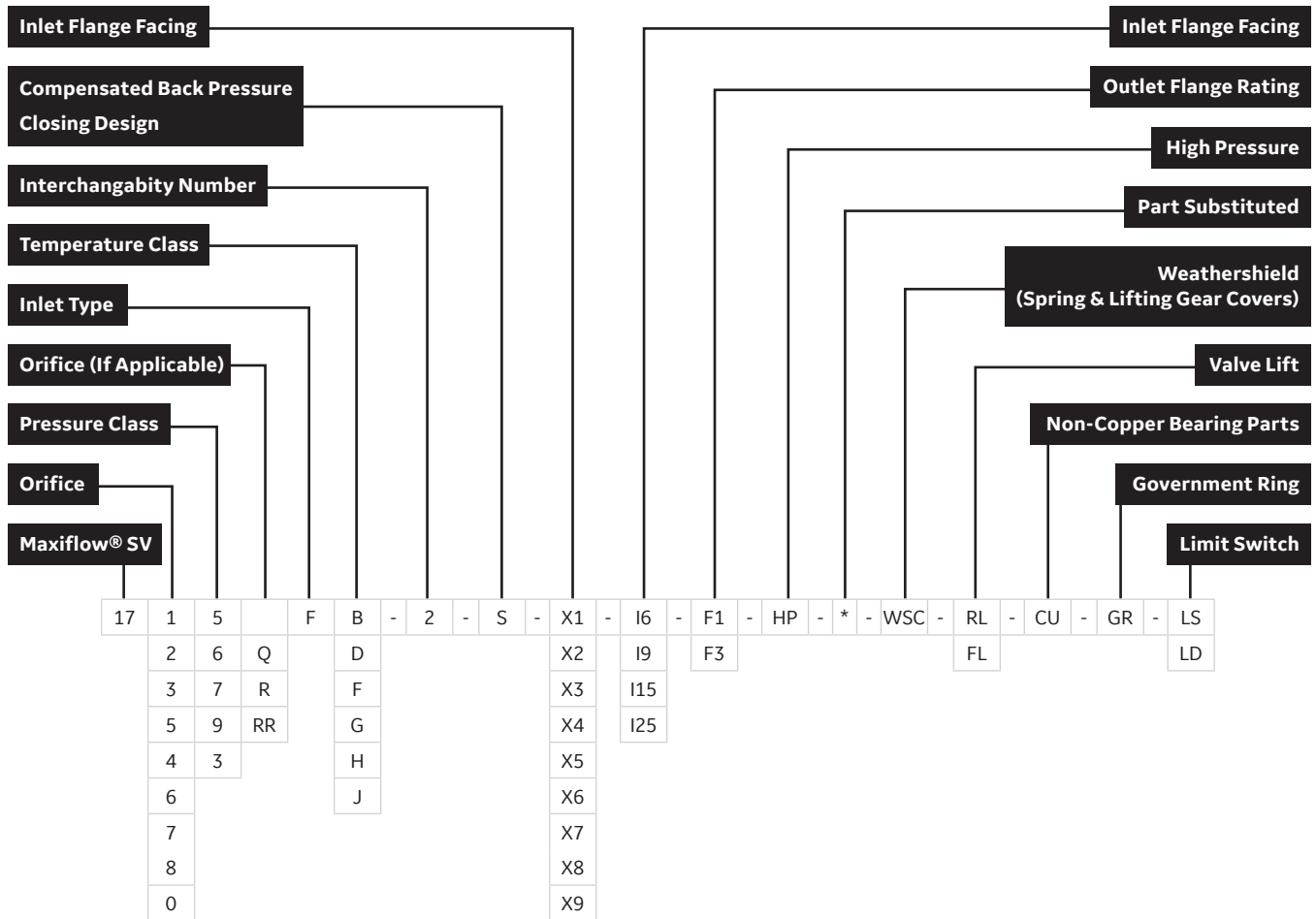

Valve Configuration Code

1700 Series Main Valve

Orifice Sizes	
1	0.994 in ²
2	1.431 in ²
3	2.545 in ²
4	3.976 in ²
5	3.341 in ²
6	7.070 in ²
7	9.974 in ²
8	14.180 in ²
0	No Meaning

Pressure Classes	
5	600 #
6	900 #
7	1500 #
9	2500 #
3	4500 #

Orifice Sizes	
Q	11.08 in ²
R	16.00 in ²
RR	19.26 in ²

Orifice Sizes	
F	Flanged
W	Welded

Temp Classes	
B	750°F
D	1020°F
F	1100°F
G	1200°F
H	1200°F
J	1200°F

Inlet Flange Facing	
X1	R.F. Serrated
X2	R.F. Smooth
X3	Ring Joint
X4	Large Tongue
X5	Large Groove
X6	Small Tongue
X7	Small Groove
X8	Large Female
X9	Misc.

Inlet Flange Rating	
I6	600 #
I9	900 #
I15	1500 #
I25	2500 #

Outlet Flange Rating	
F1	150 #
F3	300 #

Lift Types	
RL	Restricted Lift
FL	Full Lift

Limit Switches	
LS	Single Pole Double Throw
LD	Double Pole Double Throw

Inlet Neck/Seat Bushing		Base Semi-Finish			Seat Bushing		Valve Code
		WC9 E	CF8M G	C12A H			
F2	F	FEG	FGG	GHG	G	347H	-2/-3
F91	H	HEG	HGG	HHG	G	347H	-2/-3
		HEX	HGX	HHX	X	718	-2/-3
		HE	HG	HH		INLET	-6
F92	J	JEG	JGG	JHG	G	347H	-2/-3
		JEX	JGX	JHX	X	718	-2/-3
		JE	JG	JH		INLET	-6
NONE	(BLANK)	EG	JG	HG	G	347H	-5

DIRECT SALES OFFICE LOCATIONS

AUSTRALIA

Brisbane
Phone: +61-7-3001-4319
Fax: +61-7-3001-4399

Perth
Phone: +61-8-6595-7018
Fax: +61-8-6595-7299

Melbourne
Phone: +61-3-8807-6002
Fax: +61-3-8807-6577

BELGIUM
Phone: +32-2-344-0970
Fax: +32-2-344-1123

BRAZIL
Phone: +55-19-2104-6900

CHINA
Phone: +86-10-5738-8888
Fax: +86-10-5918-9707

FRANCE
Courbevoie
Phone: +33-1-4904-9000
Fax: +33-1-4904-9010

GERMANY
Ratingen
Phone: +49-2102-108-0
Fax: +49-2102-108-111

INDIA
Mumbai
Phone: +91-22-8354790
Fax: +91-22-8354791

New Delhi
Phone: +91-11-2-6164175
Fax: +91-11-5-1659635

ITALY

Phone: +39-081-7892-111
Fax: +39-081-7892-208

JAPAN

Tokyo
Phone: +81-03-6871-9008
Fax: +81-03-6890-4620

KOREA

Phone: +82-2-2274-0748
Fax: +82-2-2274-0794

MALAYSIA

Phone: +60-3-2161-0322
Fax: +60-3-2163-6312

MEXICO

Phone: +52-55-3640-5060

THE NETHERLANDS

Phone: +31-15-3808666

RUSSIA

Veliky Novgorod
Phone: +7-8162-55-7898
Fax: +7-8162-55-7921

Moscow

Phone: +7 495-585-1276
Fax: +7 495-585-1279

SAUDI ARABIA

Phone: +966-3-341-0278
Fax: +966-3-341-7624

SINGAPORE

Phone: +65-6861-6100
Fax: +65-6861-7172

SOUTH AFRICA

Phone: +27-11-452-1550
Fax: +27-11-452-6542

SOUTH & CENTRAL AMERICA AND THE CARIBBEAN

Phone: +55-12-2134-1201
Fax: +55-12-2134-1238

SPAIN

Phone: +34-93-652-6430
Fax: +34-93-652-6444

UNITED ARAB EMIRATES

Phone: +971-4-8991-777
Fax: +971-4-8991-778

UNITED KINGDOM

Bracknell
Phone: +44-1344-460-500
Fax: +44-1344-460-537

Skelmersdale

Phone: +44-1695-526-00
Fax: +44-1695-526-01

UNITED STATES

Jacksonville, Florida
Phone: +1-904-570-3409

Deer Park, Texas

Phone: +1-281-884-1000
Fax: +1-281-884-1010

Houston, Texas

Phone: +1-281-671-1640
Fax: +1-281-671-1735

bhge.com

*Denotes a trademark of Baker Hughes, a GE company, LLC.

Other company names and product names used in this document are the registered trademarks or trademarks of their respective owners.

© 2018 Baker Hughes, a GE company, LLC - All rights reserved.

Baker Hughes, a GE company, LLC and its affiliates ("BHGE") provides this information on an "as is" basis for general information purposes and believes it to be accurate as of the date of publication. BHGE does not make any representation as to the accuracy or completeness of the information and makes no warranties of any kind, specific, implied or oral, to the full extent permissible by law, including those of merchantability and fitness for a particular purpose or use. BHGE hereby disclaims any and all liability for any direct, indirect, consequential or special damages, claims for lost profits, or third party claims arising from the use of the information, whether a claim is asserted in contract, tort, or otherwise. The BHGE logo is a trademark of Baker Hughes, a GE company LLC. GE and the GE monogram are trademarks of the General Electric Company used under trademark license.

